



Grille Guard

TOLL FREE SUPPORT: 866 638 4870

Part No. 81290/1

Fits: Jeep Wrangler 2007-2011

PARTS LIST:

Qty	Part Description	Qty	Part Description
1	Driver/Left Frame Mounting Bracket	20	12mm x 24mm OD x 2.5mm Flat Washers
1	Passenger/Right Frame Mounting Bracket	10	12-1.75mm Nylon Lock Nuts
1	Driver/Left Top Mounting Bracket	2	10-1.5mm x 30mm Button Head Bolts
1	Passenger/Right Top Mounting Bracket	2	10mm x 30mm OD x 2.5mm Large Flat Washers
2	10mm Special Rod Bolts	6	10mm x 20mm OD x 2mm Flat Washers
10	12-1.75mm x 30mm Hex Bolts	4	10mm Nylon Lock Nuts

TOLL FREE SUPPORT: 866 638 4870

Install Time : 60 – 180 Minutes
(Professional Installation)
 Install Note : Cutting is required
 Assistance is recommended

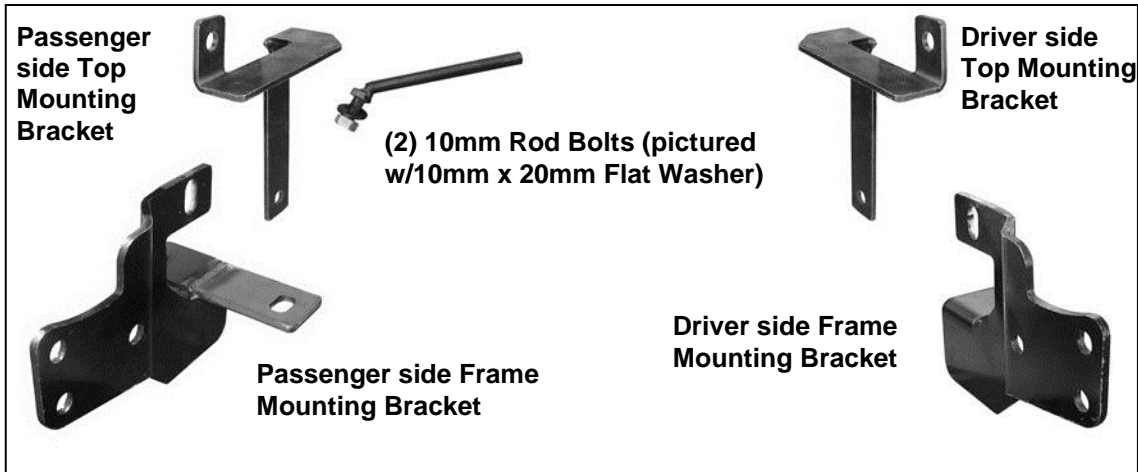

REMOVE CONTENTS FROM BOX. VERIFY ALL PARTS ARE PRESENT

READ INSTRUCTIONS CAREFULLY BEFORE STARTING INSTALLATION

INSTALLATION PROCEDURE

1. Starting under the front bumper of the vehicle, remove the plastic top fill plate between the bumper and the radiator. Also remove the lower factory splash guard. Place both on a clean, stable work surface.
2. Select the passenger side Frame Mounting Bracket. Bolt the Frame Mounting Bracket to the bottom of the crossmember with (1) 12mm x 30mm Hex Bolt, (2) 12mm Flat Washers and (1) 12mm Nylon Lock Nut. **NOTE: 07-09 models** will use the outer mounting location, (**Figure 1A**), **2010 models** will use the inner mounting location, (**Figure 1B**). Insert (1) 12mm x 30mm Hex Bolt, (2) 12mm Flat Washers and (1) 12mm Nylon Lock Nut through the upper tab on the side of the Mounting Bracket upright and tighten hardware at this time, (**Figure 2**). Repeat this step to install the driver side Frame Bracket, (**Figure 1C**).

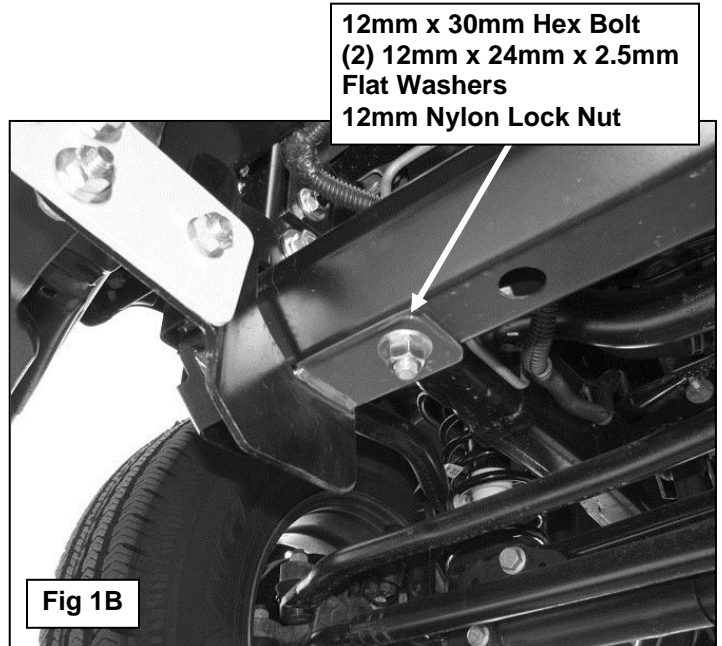
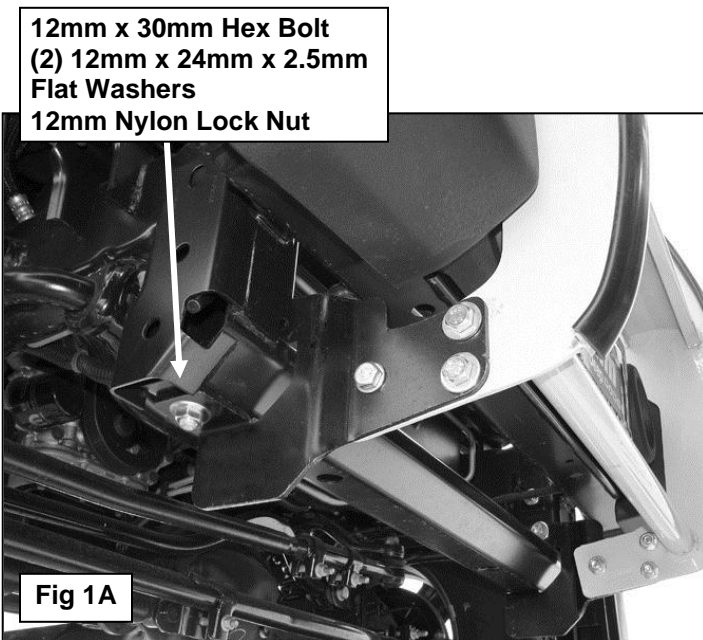

07-09 Passenger side Frame Mounting Bracket bolts to the outer mounting location (pictured with Grille Guard in position for example only)

2010 Passenger side frame mounting bracket bolts to the inner mounting location (pictured with Grille Guard in position for example only)

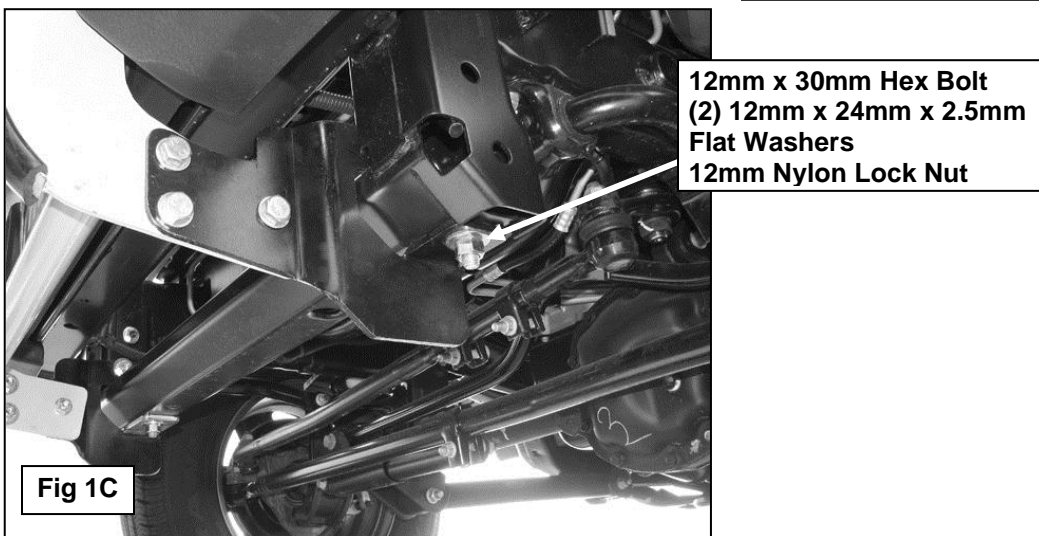

Driver side frame mounting bracket (pictured with Grille Guard in position for example only)

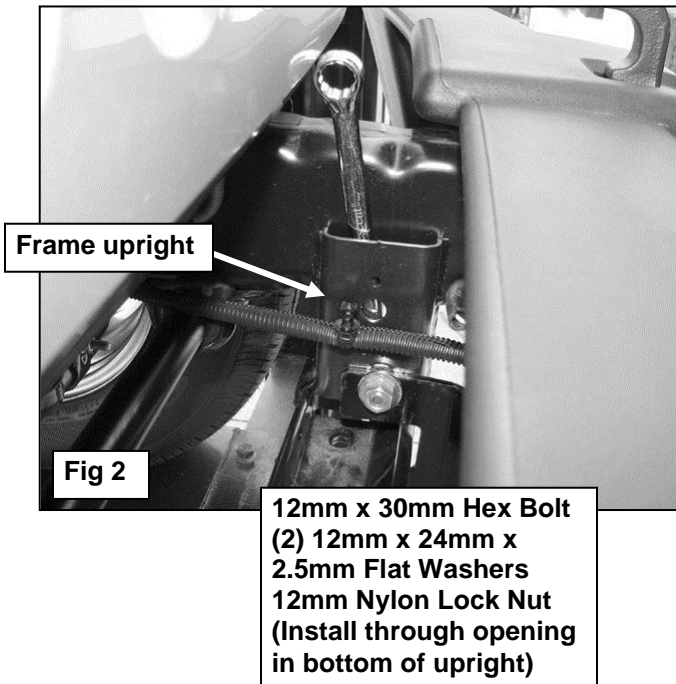

- Next, place the top fill plate back in position and mark a slot on the underside straight up from the frame upright, (the top brackets mount to the side of the frame upright-see Figure 5). Cut (2) slots to clear the Top Brackets, **(Figure 3)**. **NOTE:** Only cut a slot long enough to clear the Top Mounting Brackets. **IMPORTANT!** Do not cut completely through either end of the fill panel. Reinstall the fill panel with the factory hardware.

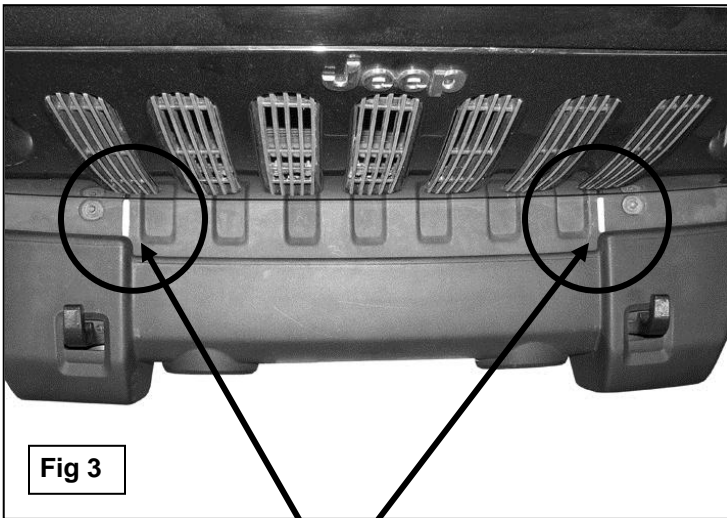

Reinstall the fill panel and mark the cut area on the inside of the fill panel straight up from the frame upright. Start with a small opening and slowly enlarge the opening to get the best fit around the brackets. Area cut from fill panel pictured for example only.

- Select (1) 10mm Rod Bolt and (1) 10mm x 20mm OD Flat Washer. From the driver side, insert the Rod Bolt and Flat Washer into the opening at the base of the frame upright and out the factory hole on the side of the upright above the tab on the previously installed Frame Mounting Bracket, **(Figure 4)**. Hold the Rod Bolt in place and insert the driver side Top Mounting Bracket through the slots cut in the fill panel. Secure the Top Bracket to the side of the frame upright with the included (1) 10mm x 30mm Large Flat Washer

and (1) 10mm Nylon Lock Nut, **(Figure 5)**. Do not tighten hardware at this time. Repeat this step for the passenger side Top Mounting Bracket installation.

(1) 10mm Rod Bolt
(1) 10mm x 20mm
OD Flat Washer
(not pictured)

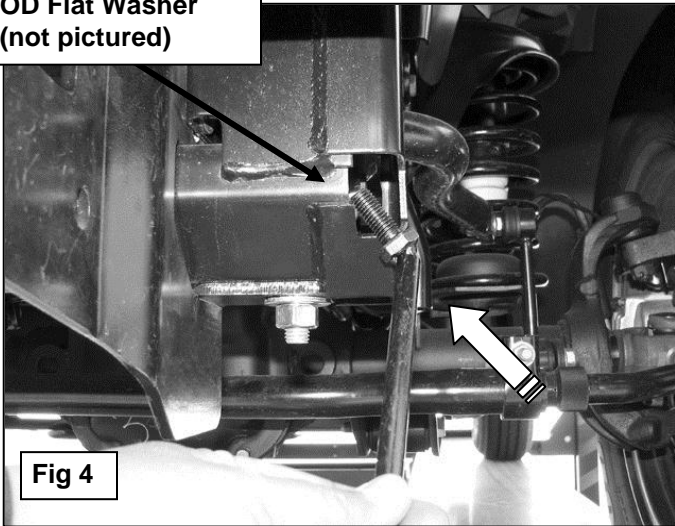
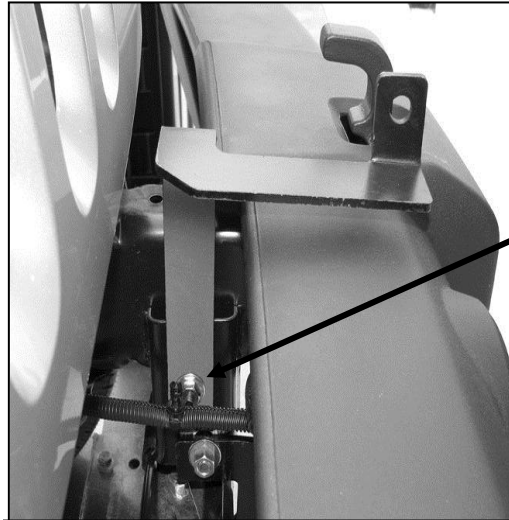

Fig 4



(1) 10mm Rod Bolt
(1) 10mm x 20mm
OD Flat Washer
(inner)
(1) 10mm x 30mm
OD Flat Washer
(outer)
(1) 10mm Nylon Lock
Nut

(Fig 5) Pictured without fill plate for example only

- With assistance, lift the Grille Guard up to the inside of the Frame Mounting Brackets. Line up the holes in the Frame Mounting Brackets with the holes in the Grille Guard. Insert (6) 12-1.75mm x 30mm Hex Bolts, (12) 12mm Flat Washers and (6) 12mm Nylon Lock Nuts, **(Figure 6)**. Push the grille guard back into an upright position. Secure the Top Brackets to the grille guard with the included (2) 10mm x 30mm Button Head Allen Bolts, (4) 10mm x 20mm OD Flat Washers and (2) 10mm Nylon Lock Nuts. Adjust the Brackets as necessary then snug but do not tighten all of the hardware.

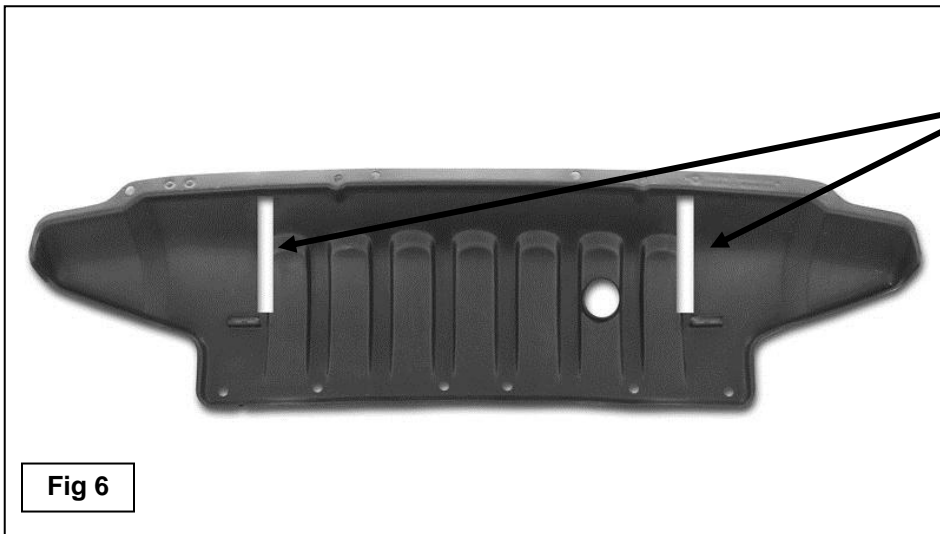

Fig 6

Once the Mounting Brackets have been installed and checked for alignment, hold the splash guard up into position and mark the cut area on the inside of the guard. Start with a small opening and slowly enlarge the opening to get the best fit around the brackets. Area cut from guard pictured for example only. (Interior view)

- Stand back from the vehicle and check to see that the Grille Guard is centered and level on the vehicle and adjust as necessary. It may be necessary to slightly loosen the Frame mounting brackets to properly align the Grille Guard. **IMPORTANT:** Once properly aligned, tighten all of the hardware.

- (1) 10mm x 30mm Button Head Allen Bolt
- (2) 10mm x 20mm OD Flat Washers
- (1) 10mm Nylon Lock Nut

- (3) 12mm x 30mm Hex Bolts
- (6) 12mm x 24mm OD x 2.5mm Flat Washers
- (3) 12mm Nylon Lock Nuts

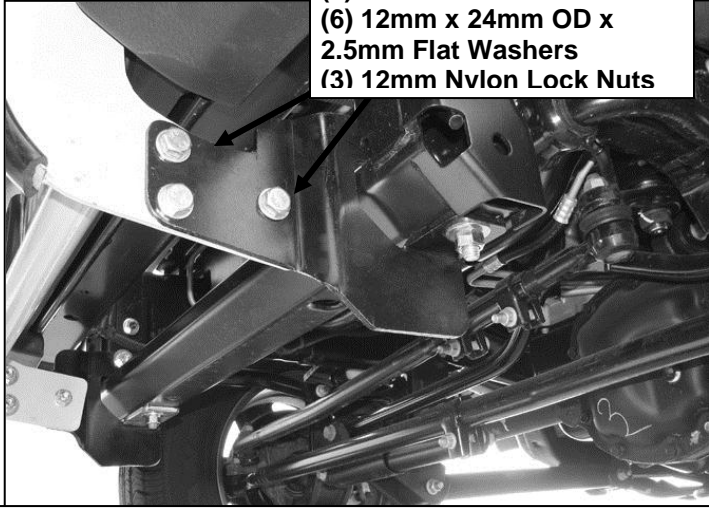

(Fig 7) Pictured without splash guard for example only

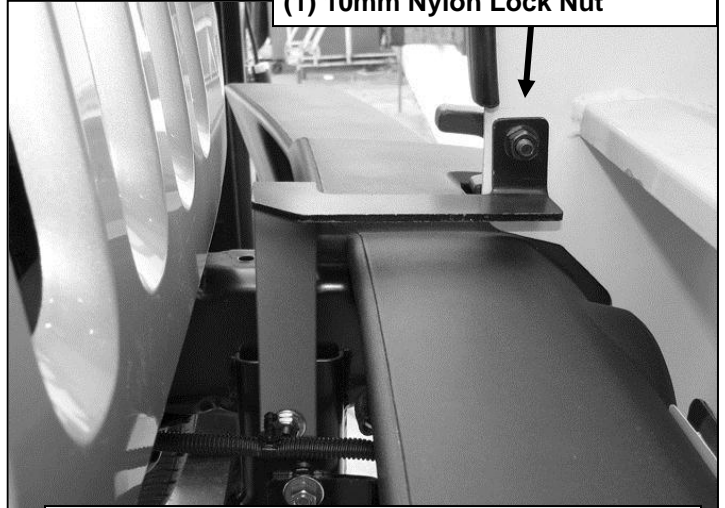

(Fig 8) Pictured without fill plate for example only

Do periodic inspections to the installation to make sure that all hardware is secure and tight.

To protect your investment, wax this product after installing. Regular waxing is recommended to add a protective layer over the finish. Do not use any type of polish or wax that may contain abrasives that could damage the finish.

For stainless steel: Aluminum polish may be used to polish small scratches and scuffs on the finish. Mild soap may be used also to clean the Sidebar.

For gloss black finishes: Mild soap may be used to clean the Product.

Keystone Automotive Operations Inc. (KAO) warrants this product to be free of defects in material and workmanship at the time of purchase by the original retail consumer. KAO disclaims any other warranties, express or implied, including the warranty of fitness for a particular purpose or an intended use. If the product is found to be defective, KAO may replace or repair the product at our option, when the product is returned prepaid, with proof of purchase. Alteration to, improper installation, or misuse of this product voids the warranty. KAO's liability is limited to repair or replacement of products found to be defective, and specifically excludes liability for any incidental or consequential loss or damage.