

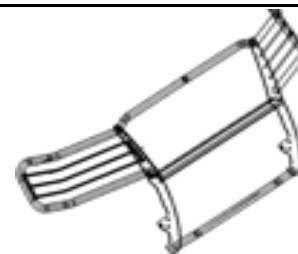

# Grille Guard

## Part No. 81300/81301



Fits: **2005 - 2007**  
**2005 - Current**

**Nissan Pathfinder**  
**Nissan Frontier**



Existing underbody shields must be removed or modified to install. Tow hooks must be removed, if equipped. The Grille Guards may interfere with parking sensors, proximity sensors and external cruise control sensors.



REMOVE CONTENTS FROM BOX. VERIFY ALL PARTS ARE PRESENT.



READ INSTRUCTIONS CAREFULLY BEFORE STARTING INSTALLATION.

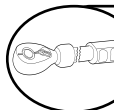

DO NOT OVER TORQUE. STANDARD OPERATING LOAD FOR TIGHTEN BODY MOUNT NUTS & BOLTS VARIES FROM **45** TO **65** FOOT POUND.



60-180 min

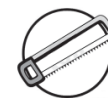

Cutting Is Required



Drilling Not Required



[support@trailfx.com](mailto:support@trailfx.com)



1 866 638 4870



POLISHED STAINLESS STEEL – LIMITED LIFETIME  
POWDER COATED BLACK – 3 YEARS

### PARTS LIST:

Qty	Part Description	Qty	Part Description
1	Grille Guard	10	12mm Lock Washers
1	Driver/Left Mounting Bracket	16	12mm ID x 32mm OD x 3mm Flat Washers
1	Passenger/Right Mounting Bracket	6	12-1.75mm Hex Nuts
1	Driver/Left Top Bracket (for 05-08 vehicles)	2	10-1.50mm x 25mm Button Head Allen Bolt
1	Passenger/Right Top Bracket (for 05-08 vehicles)	4	10mm ID x 20mm OD x 2mm Flat Washers
1	Driver/Left Top Bracket (for 09 vehicles)	2	10mm Nylon Lock Nut
1	Passenger/Right Top Bracket (for 09 vehicles)	2	8-.125mm x 25mm Hex Bolts
2	8mm x 25mm Nut Plates	2	8mm Lock Washers
4	12-1.25mm x 40mm Hex Head Bolts (fine thread)	2	8mm x 24mm OD x 2mm Flat Washers
6	12-1.75mm x 35mm Hex Head Bolts		

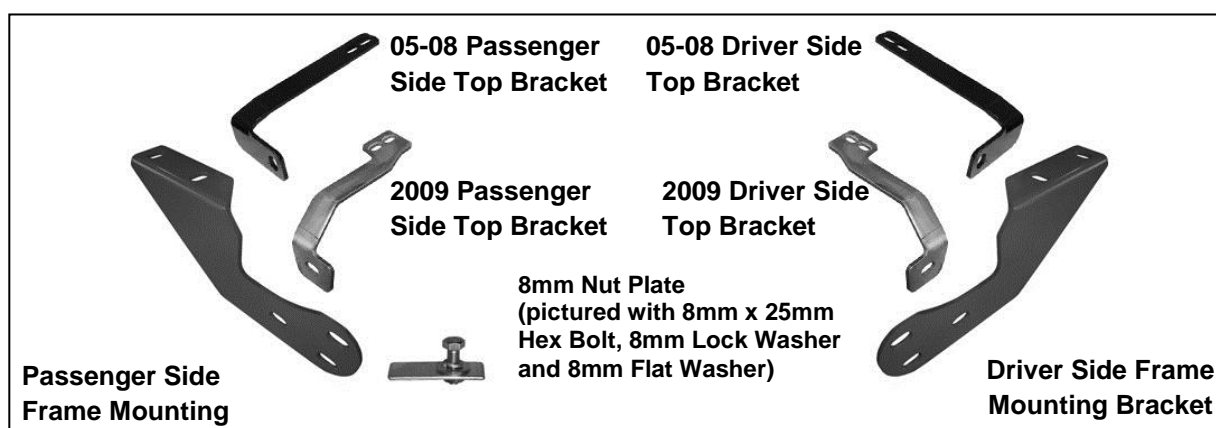

### INSTALLATION PROCEDURE:

#### ASSISTANCE IS RECOMMENDED.

- From under the front of the vehicle, remove the 6 bolts and/or clips securing the center plastic splash guard to the vehicle. Move the splash guard to a clean, stable work surface. Remove the factory tow hook located on the passenger side.  
**NOTE:** You will not be re-installing tow hook.

2. Locate the driver side Mounting Bracket and partially hang it from factory threaded holes on the frame rail using the included (2) 12-1.25 x 40mm Hex Head Bolts (fine thread), (2) 12mm Lock Washers, and (2) 12mm Flat Washers, **(Figure 1)**. Repeat this step for passenger side.
3. Use a hack saw to cut out the driver side tow hook cavity on the splash guard, **(Figure 2)**. Once you have cut out the tow hook cavity, place the splash guard up to the vehicle to check for clearance around the Mounting Brackets. If necessary, cut an additional  $\frac{1}{2}$ " x 2" slot in the front side of each tow hook cavity to clear the Mounting Bracket, **(Figure 3)**. Once you have cut out the plastic splash guard, reinstall it using the factory hardware.

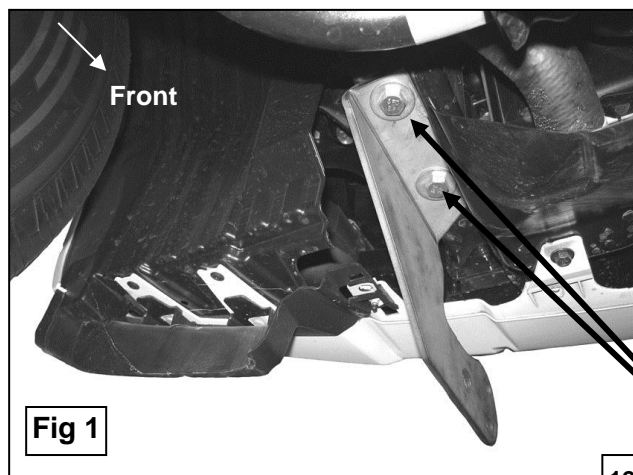

Fig 1

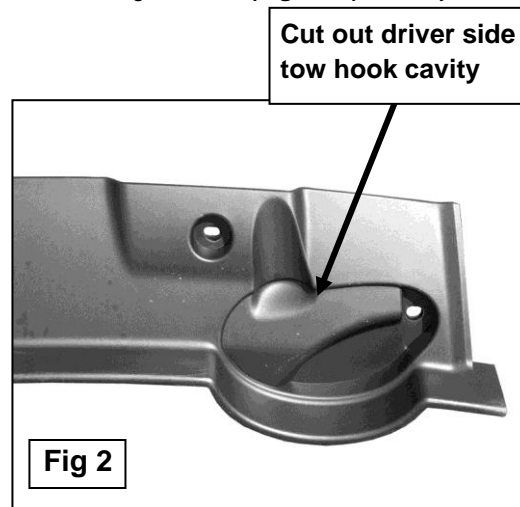

Fig 2

12-1.25mm x 40mm Fine Thread Hex Bolts  
12mm Lock Washers  
12mm Flat Washers

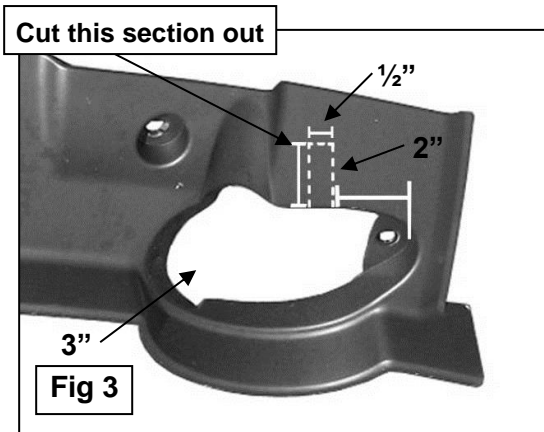

Fig 3



4. Locate and remove the two plastic clips located in the grille opening. Insert (1) 8mm x 25mm Nut plate into the opening and line up the threaded hole with the hole in the grille opening, **(Figure 4)**.

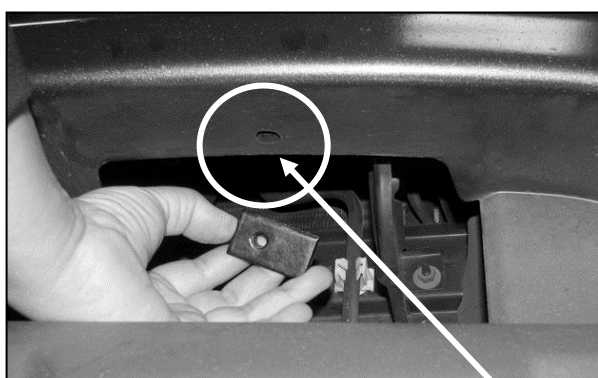

Fig 4

Remove plastic factory clips. Insert 8mm Nut plate into opening in grille and line up with this hole

5. Line up the hole in the Top Bracket, **(see Figure 5 to determine correct Top Bracket)** with the Nut Plate and secure the Top Bracket with (1) 8mm x 25mm Hex Bolt, (1) 8mm Flat Washer and (1) 8mm Lock Washer, **(Figure 6)**. **NOTE:** Two slotted holes are provided to allow for proper fit to the vehicle. Snug but do not tighten hardware at this time. Repeat this step for the passenger side Top Bracket installation.

05-08 driver side Top Bracket



Fig 5

09 driver side Top Bracket



8mm x 25mm Hex Bolts  
8mm Lock Washers  
8mm Flat Washers

05-08 driver side Top Bracket installation pictured



Fig 6

6. With assistance, position the Grille Guard bolt tabs up to the outside of the Mounting Brackets. Attach the Grille Guard to the Mounting Brackets using the included (6) 12mm x 35mm Hex Head Bolts, (6) 12mm Lock Washers, (12) 12mm Flat Washers and (6) 12mm Hex Nuts, (Figure 7). Do not tighten at this time.
7. Push the Grille Guard back into position and line up the holes in the Top Brackets with the holes in the Grille Guard uprights. **NOTE:** It may be necessary to move the Top Bracket in or outward in the slots to line up properly with the Grille Guard. Attach the Top Brackets to the inside of the Grille Guard uprights using the included (2) 10mm Button Head Allen Bolts, (4) 10mm Flat Washers and (2) 10mm Nylon Lock Nuts, (Figure 8).

12-1.75mm x 35mm Hex Bolts  
12mm Lock Washers  
12mm Hex Nuts  
12mm Flat Washers

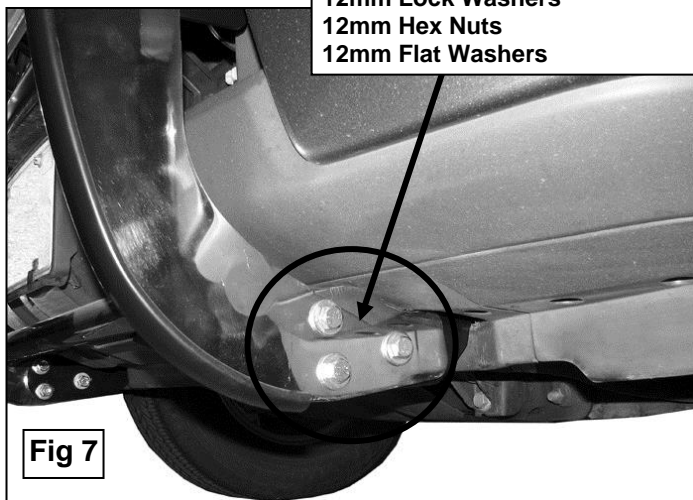

Fig 7

(1) 10mm x 25mm Button Head Bolt  
(2) 10mm Flat Washers  
(1) 10mm Nylon Lock Nut

05-08 driver side Top Bracket installation pictured

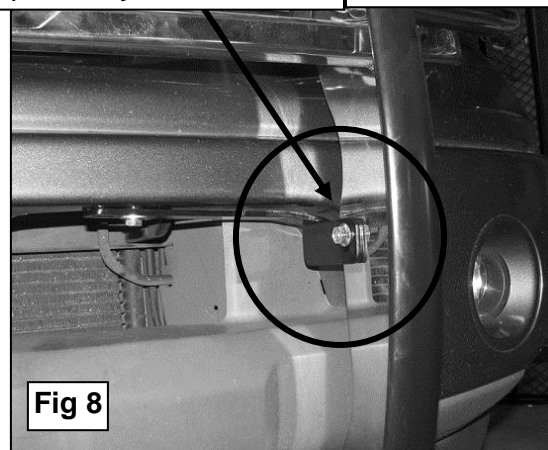

Fig 8



**Installation Complete**

8. Align the Grille Guard properly and tighten all hardware. **NOTE:** *Slowly* open the hood to make sure that the Grille Guard does not interfere with hood opening and closing.
9. Do periodic inspections to the installation to make sure that all hardware is secure and tight.

**PRODUCT CARE**

- Periodically check the product to ensure all fasteners are tight and components are intact.
- Regular waxing is recommended to protect the finish of the product.
- **Use ONLY Non-Abrasive automotive wax.** Use of any soap, polish or wax that contains an abrasive is detrimental and can scratch the finish leading to corrosion.
- Aluminum polish may be used to polish small scratches and scuffs for **Stainless Steel finish.**
- Mild soap may be used to clean the product for both **Stainless Steel and Black finish.**

**FAQ's****1. Hardware's are not of correct size.**

*In GMC / Chevrolet truck model 2006 & up, customer needs to reuse the factory body bolts to install the bracket. If your vehicle is not GMC / Chevrolet 2006 & up, ensure that holes are not partially covered with any plastic grommet or rust? If it is, remove the plastic grommet & rust from the thread holes & re-try the installation.*

**2. Mounting Bracket are not getting Installed properly.**

*In some cases Illustration images shown in Installation manual may not be the exactly same as per actual vehicle images ,also if Driver / Passenger side mounting brackets are very identical in the design, suggest referring Parts Identification guide to avoid fitment issue.*

**3. Products are thumping / rattling after installation.**

*Ensure that all required mounting brackets / hardware's are installed & tighten correctly. Suggest using white lithium / regular grease between the metal to metal contact surfaces.*

**4. Side Bar is not aligning with vehicle / Step Pads are not aligning with vehicle doors.**

*Side bar may be interchanged or mounting brackets are not installed at the correct position in the vehicle. Refer Parts identification guide.*

**5. Missing / Excess Hardware.**

*Recheck hardware count as per the part list.*

**6. Product not installing properly.**

*Ensure make model year, cab length and bed size of your vehicle is listed in the application. All installation steps are followed correctly.*

**Check out these other TrailFX Products!!**

**www.TrailFX.com**



**SIDE BAR**

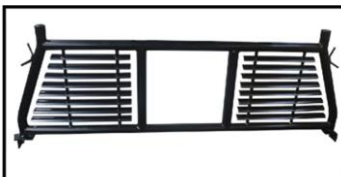

**HEADACHE RACKS**

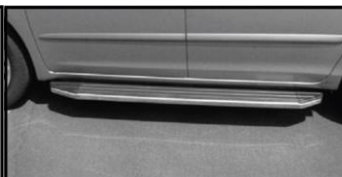

**RUNNING BOARDS**



**ROCKER GUARDS**

Keystone Automotive Operations Inc. (KAO) warrants this product to be free of defects in material and workmanship at the time of purchase by the original retail consumer. KAO disclaims any other warranties, express or implied, including the warranty of fitness for a particular purpose or an intended use. If the product is found to be defective, KAO may replace or repair the product at our option, when the product is returned prepaid, with proof of purchase. Alteration to, improper installation, or misuse of this product voids the warranty. KAO's liability is limited to repair or replacement of products found to be defective, and specifically excludes liability for any incidental or consequential loss or damage.