



Grille Guard

Part No. 81260 / 81261



Fits: **2006-2010**
2009-2010

Hummer H3
Hummer H3T



THE GRILLE GUARD MAY INTERFERE WITH PARKING SENSORS, PROXIMITY SENSORS AND CRUISE CONTROL SENSORS.



REMOVE CONTENTS FROM BOX. VERIFY ALL PARTS ARE PRESENT.



READ INSTRUCTIONS CAREFULLY BEFORE STARTING INSTALLATION.

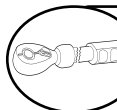

DO NOT OVER TORQUE. STANDARD OPERATING LOAD FOR TIGHTEN BODY MOUNT NUTS & BOLTS VARIES FROM 45 TO 65 FOOT POUND.



60-180 min



Cutting Not Required



Drilling Not Required



support@trailfx.com



1 866 638 4870



POLISHED STAINLESS STEEL – LIMITED LIFETIME
POWDER COATED BLACK – 3 YEARS

PARTS LIST:

Qty	Part Description	Qty	Part Description
1	Grille Guard	4	8mm x 24mm OD x 2mm Flat Washers
1	Driver/Left Top Support Bracket	2	8mm Acorn Nuts
1	Passenger/Right Top Support Bracket	1	5mm Allen Wrench
2	8-1.25mm x 20mm Button Head Allen Bolts		

- Starting on the passenger side, remove the factory tow D-ring and bracket and set aside, **(Figures 1 - 3)**. **NOTE:** In order to get to the factory tow hook mounting bracket, remove the large horizontal bolt, **(Figure 1)**. Repeat to remove the driver side tow hook and bracket.
- With assistance, position the Grille Guard up to the vehicle, **(Figure 4)**. Line up the brackets on the Grille Guard with the holes for the tow hook. Attach the Grille Guard and tow hook brackets to the bumper with the factory bolts removed in Step 2, **(Figure 4)**. Do not tighten at this time. **CAUTION:** Do not attempt to install Front Guard by yourself; doing so, you may damage the finish on the vehicle.

Remove factory bolt to access mounting bolts behind D-Rings

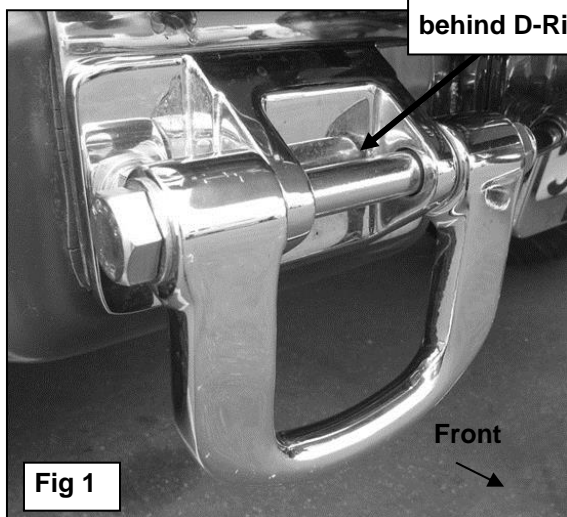

Fig 1



Fig 2

Remove factory bolt to access mounting bolts behind D-Rings

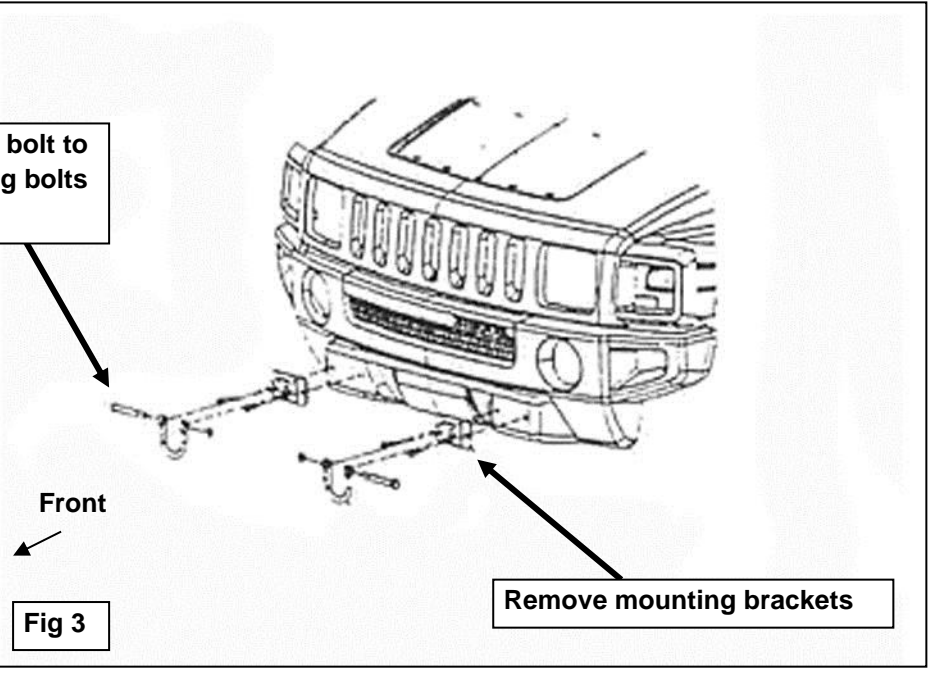

Fig 3

Remove mounting brackets

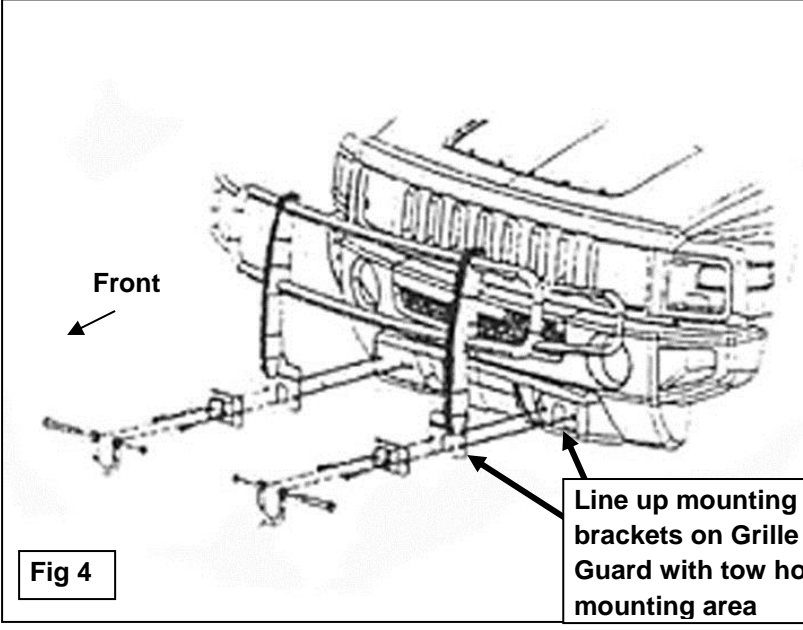
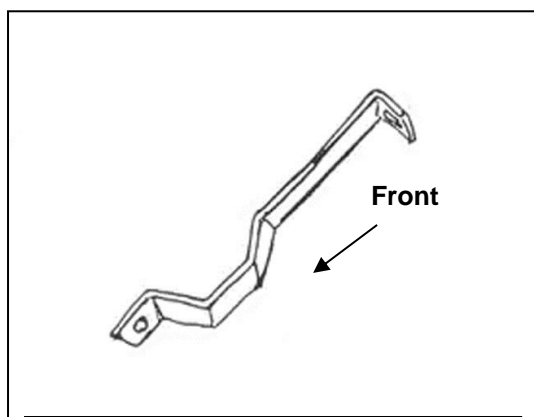

Fig 4

Line up mounting brackets on Grille Guard with tow hook mounting area

3. Select the passenger side Top Bracket, **(Figure 5)**. Remove the factory bolt located in the outer grille opening on the passenger side, **(Figure 6)**. Line up the hole in the bent end of the passenger side Support Bracket with the mounting hole in the grille opening. Use the factory hex bolt to attach the Top Support Bracket to the vehicle. Line up the remaining mounting hole in the Top Bracket with the hole in the Grille Guard upright. Bolt the Bracket to the upright with the included (1) 8-1.25mm x 20 mm Button Head Bolt, (2) 8mm Flat Washers and (1) 8mm Acorn Nut, **(Figures 6 - 7)**. Do not tighten hardware at this time.
4. Repeat Step 4 for driver side Top Support Bracket installation.
5. Level and adjust the Grille Guard and tighten all hardware.
6. Re-install the factory D-rings removed in Step 2 and tighten hardware.



(Fig 5) Passenger side Top Bracket

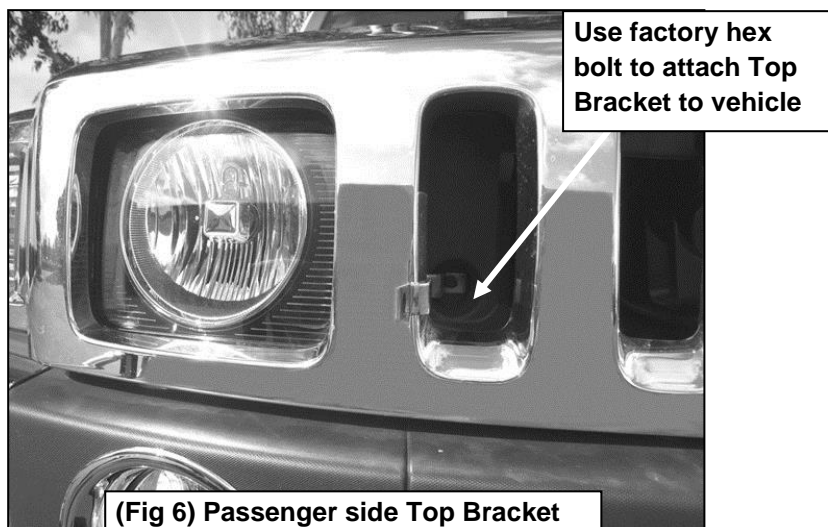

(Fig 6) Passenger side Top Bracket

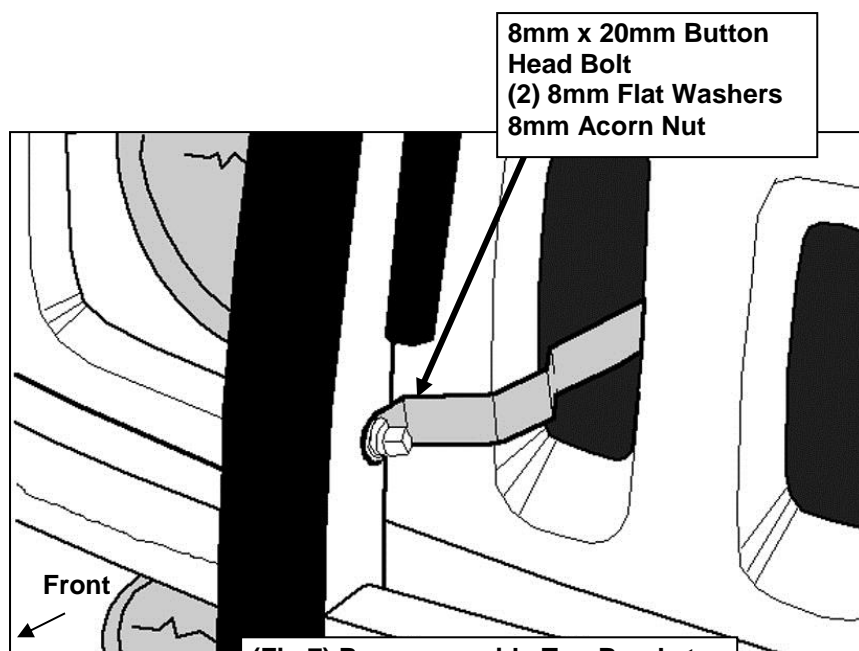

(Fig 7) Passenger side Top Bracket

PRODUCT CARE

- Periodically check the product to ensure all fasteners are tight and components are intact.
- Regular waxing is recommended to protect the finish of the product.
- **Use ONLY Non-Abrasive automotive wax.** Use of any soap, polish or wax that contains an abrasive is detrimental and can scratch the finish leading to corrosion.
- Aluminum polish may be used to polish small scratches and scuffs for **Stainless Steel finish.**
- Mild soap may be used to clean the product for both **Stainless Steel and Black finish.**

FAQ's**1. Hardware's are not of correct size.**

In GMC / Chevrolet truck model 2006 & up, customer needs to reuse the factory body bolts to install the bracket. If your vehicle is not GMC / Chevrolet 2006 & up, ensure that holes are not partially covered with any plastic grommet or rust? If it is, remove the plastic grommet & rust from the thread holes & re-try the installation.

2. Mounting Bracket are not getting Installed properly.

In some cases Illustration images shown in Installation manual may not be the exactly same as per actual vehicle images ,also if Driver / Passenger side mounting brackets are very identical in the design, suggest referring Parts Identification guide to avoid fitment issue.

3. Products are thumping / rattling after installation.

Ensure that all required mounting brackets / hardware's are installed & tighten correctly. Suggest using white lithium / regular grease between the metal to metal contact surfaces.

4. Side Bar is not aligning with vehicle / Step Pads are not aligning with vehicle doors.

Side bar may be interchanged or mounting brackets are not installed at the correct position in the vehicle. Refer Parts identification guide.

5. Missing / Excess Hardware.

Recheck hardware count as per the part list.

6. Product not installing properly.

Ensure make model year, cab length and bed size of your vehicle is listed in the application. All installation steps are followed correctly.

Check out these other TrailFX Products!!

www.TrailFX.com



SIDE BAR



HEADACHE RACKS



RUNNING BOARDS



ROCKER GUARDS

Keystone Automotive Operations Inc. (KAO) warrants this product to be free of defects in material and workmanship at the time of purchase by the original retail consumer. KAO disclaims any other warranties, express or implied, including the warranty of fitness for a particular purpose or an intended use. If the product is found to be defective, KAO may replace or repair the product at our option, when the product is returned prepaid, with proof of purchase. Alteration to, improper installation, or misuse of this product voids the warranty. KAO's liability is limited to repair or replacement of products found to be defective, and specifically excludes liability for any incidental or consequential loss or damage.