

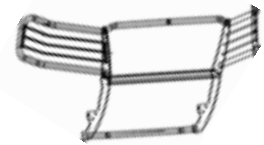

# Grille Guard

## Part No. 81230/1



Fits: 2006 - 2008

Dodge Ram 1500 (Except Mega Cab)



Cutting of air dam is necessary to complete installation. Minor trimming of air dam may be required.  
Excludes Dodge Ram Rebel Editions Vehicle



REMOVE CONTENTS FROM BOX. VERIFY ALL PARTS ARE PRESENT.



READ INSTRUCTIONS CAREFULLY BEFORE STARTING INSTALLATION.

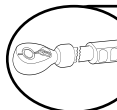

DO NOT OVER TORQUE. STANDARD OPERATING LOAD FOR TIGHTEN BODY MOUNT NUTS & BOLTS VARIES FROM 45 TO 65 FOOT POUND.



60-180 min

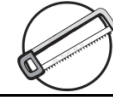

Cutting Required



Drilling Not Required

[support@trailfx.com](mailto:support@trailfx.com)



1 866 638 4870



POLISHED STAINLESS STEEL – LIMITED LIFETIME  
POWDER COATED BLACK – 3 YEARS

### PARTS LIST:

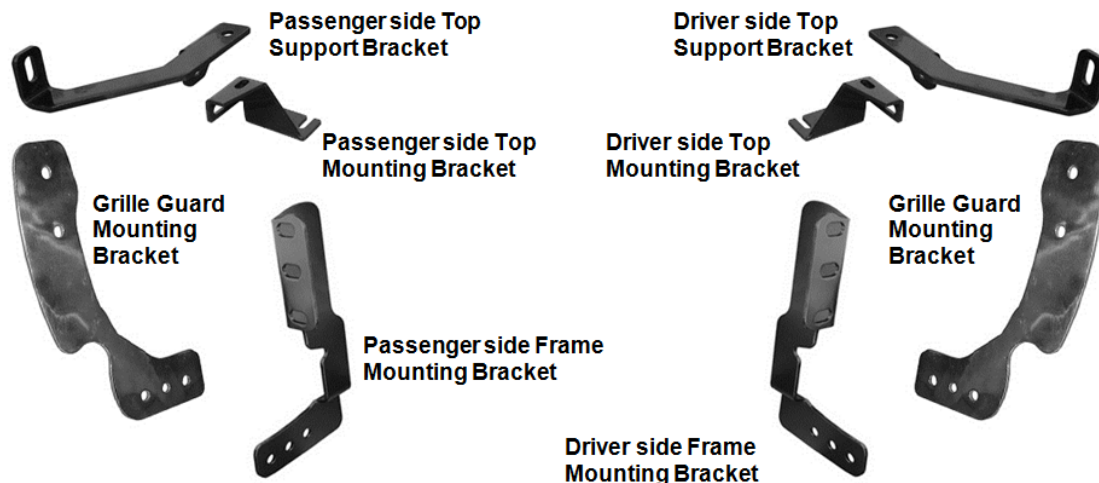
Qty	Part Description	Qty	Part Description
1	Driver/Left Frame Mounting Bracket	12	12mm x 24mm OD x 2.5mm Flat Washers
1	Passenger/Right Frame Mounting Bracket	10	12-1.75mm Nylon Lock Nuts
2	Mounting Brackets	2	10-1.5mm x 35mm Hex Bolts
2	Top Mounting Brackets	4	10mm x 20mm OD x 2mm Flat Washers
1	Driver/Left Top Support Bracket	2	10mm Nylon Lock Nuts
1	Passenger/Right Top Support Bracket	1	5mm Wrench
10	12-1.75mm x 35mm Hex Bolts	2	8mm x 25mm Button Head Allen Bolts
12	12mm x 32mm OD x 3mm Flat Washers	4	8mm x 16mm OD x 1.6mm Flat Washers
		2	8mm Nylon Lock Nuts



### INSTALLATION PROCEDURE

- Begin the installation at the underside of the front bumper. Carefully release the bolts and/or factory clips and remove the plastic spoiler. **NOTE:** It may be necessary to remove the bumper mounted factory fog light or cover (if equipped) to access the spoiler hardware. Place the spoiler on a clean, stable work surface.
- Starting on the passenger side, remove the (2) factory hex nuts from the bumper bolts securing the bumper bracket to the back of the bumper. Select the driver side Frame Mounting Bracket and hold it up behind the bumper. Align the holes in the Frame Mounting Bracket with the (2) bumper bolts. Attach the Bracket to the bumper bolts using the factory hex nuts, (**Figure 1**). Snug but do not tighten the hardware at this time.

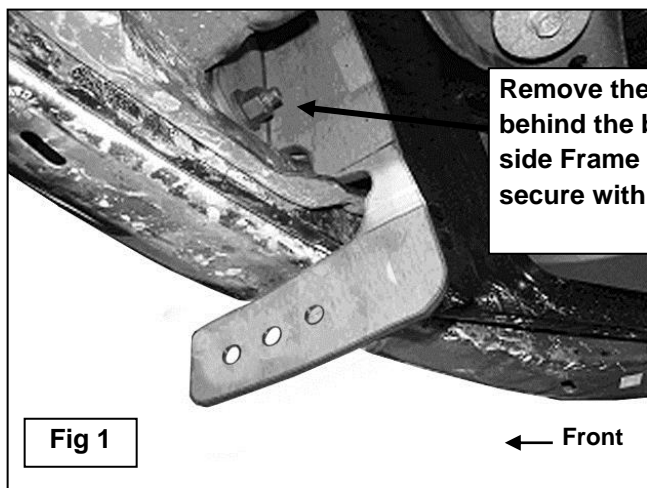

Remove the (2) factory hex nuts from behind the bumper. Install the driver side Frame Mounting Bracket and secure with the factory hex nuts

3. Cover the top of the bumper cover with a layer of masking tape to prevent damage to the cover during bracket installation, **(Figure 4)**. Remove the (2) factory hex bolts located on the bottom of the crossmember, **(Figure 2A & 2B)**. Select the passenger side Top Frame Mounting Bracket and attach it to the crossmember using the factory hex bolts, **(Figure 3)**. Push the Bracket back against the crossmember and tighten the factory hardware on this bracket only at this time.
4. Secure the passenger side Top Bracket to the Top Mounting Bracket with the included (1) 10mm x 35mm Hex Bolt, (2) 10mm Flat Washers and (1) 10mm Nylon Lock Nut. Insert (1) 12mm x 35 mm Hex Bolts, (2) 12mm Flat Washers and (1) 12mm Nylon Lock Nut through the slotted hole on the side of the Top Bracket, **(Figure 4)**. Snug but do not tighten hardware at this time.

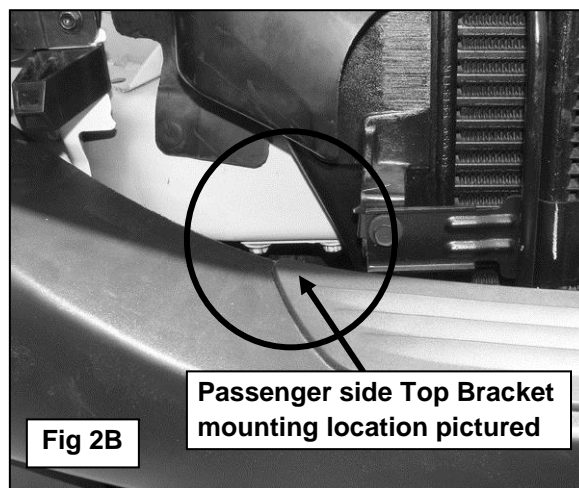
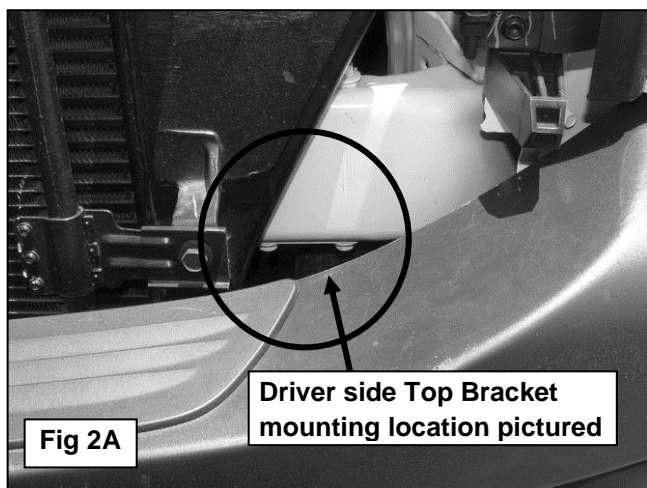

Use the 8mm factory hex bolt to attach the Top Mounting Bracket to the crossmember

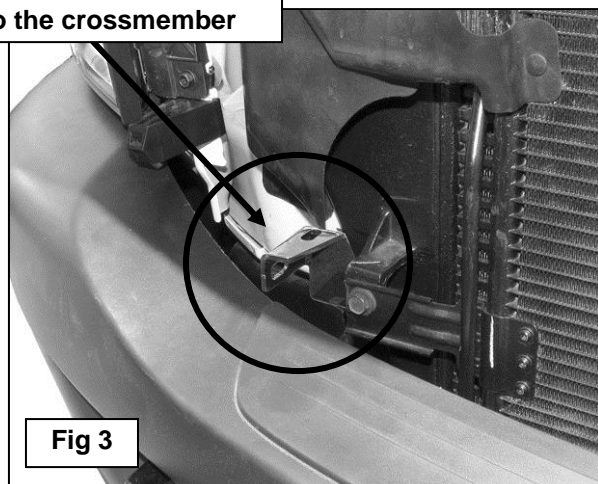

**12-1.75mm x 35mm Hex Bolts**  
**12mm x 24mm OD x 2.5mm Flat Washers**  
**12mm Nylon Lock Nuts**

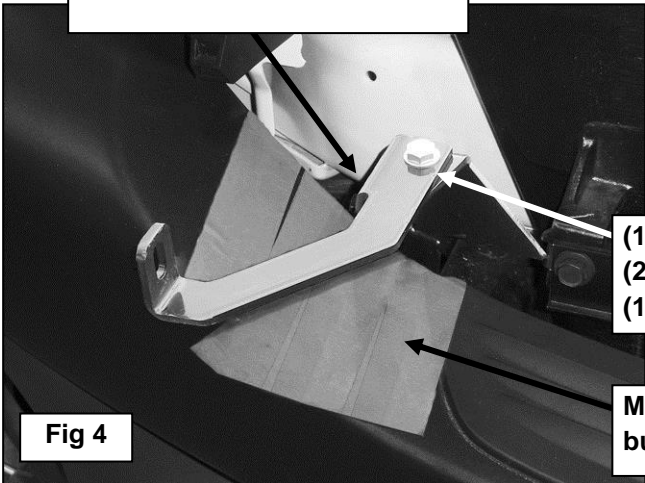

**(1) 10mm x 35mm Hex Bolt**  
**(2) 10mm Flat Washers**  
**(1) 10mm Nylon Lock Nut**

**Masking tape used to protect bumper cover during installation**

**Fig 4**

5. Repeat Steps 3-5 for the driver side Mounting Bracket installation.
  
6. Lay the Grille Guard face down on a clean surface on the ground in front of the vehicle. Bolt the Mounting Brackets to each upright on the Grille Guard using the included (4) 12-1.75mm x 35mm Hex Head Bolts, (8) 12mm x 24mm OD x 2.5mm Flat Washers, and (4) 12mm Nylon Lock Nuts, (2 per side, see **Figure 5**). Tighten this hardware only at this time.

**Bolt the Grille Guard Mounting Brackets to the inside of the Grille Guard with:**

**(2) 12-1.75mm x 35mm Hex Bolts**

**(4) 12mm x 24mm OD x 2.5mm Flat Washers**

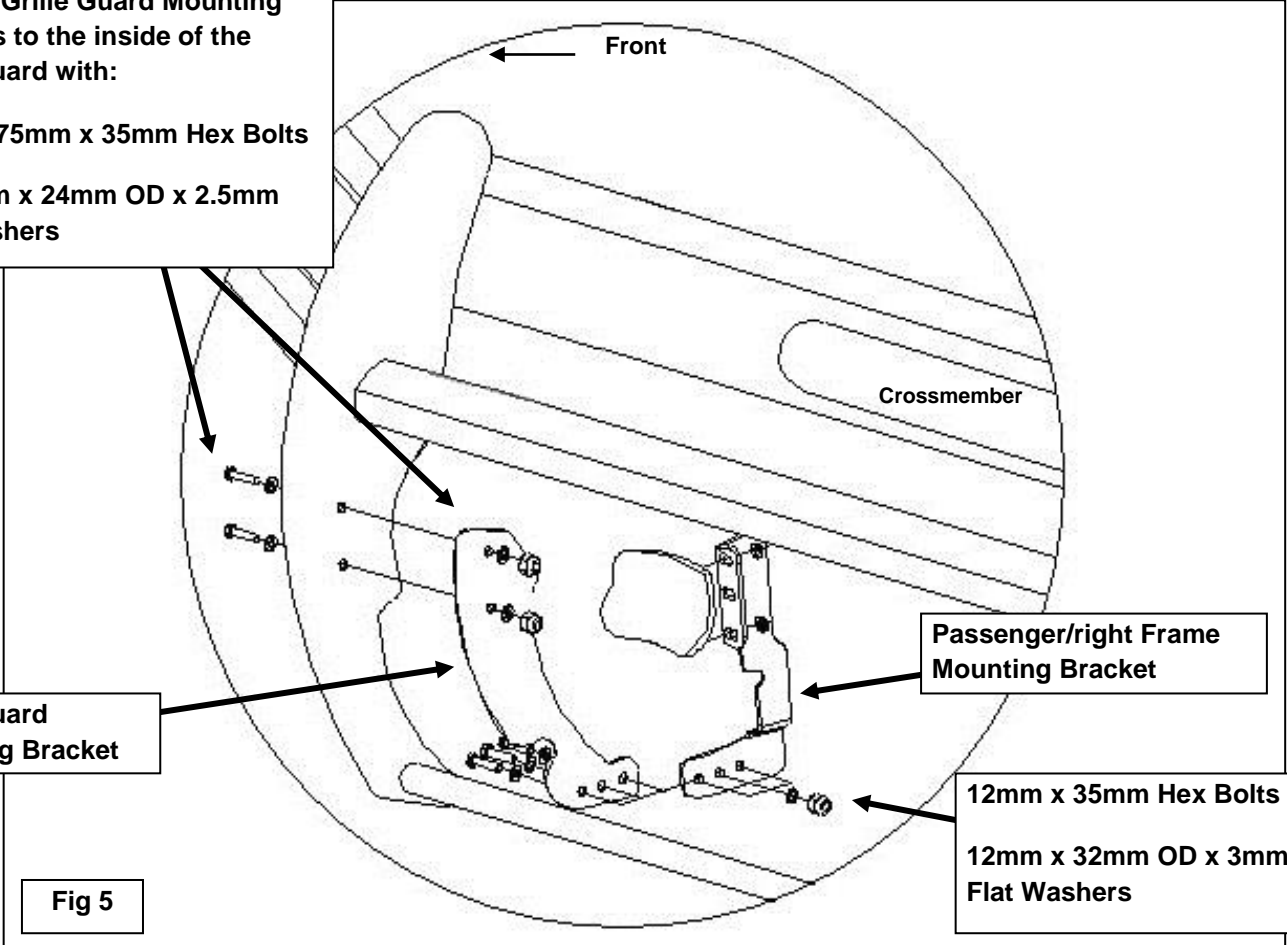

**Passenger/right Frame Mounting Bracket**

**Grille Guard Mounting Bracket**

**12mm x 35mm Hex Bolts**  
**12mm x 32mm OD x 3mm Flat Washers**

**Fig 5**

7. Raise the Mounting Brackets on the Grille Guard up to the outside of the Frame Mounting Brackets. Insert (1) 12-1.75mm x 35mm Hex Head Bolt, (2) 12mm 32mm OD x 3mm Flat Washers and (1)12mm Nylon Lock Nut into each of the rear-most mounting holes to act as a hinge. With assistance, rotate the Grille Guard up to line up with the Top Brackets and insert (4) 12-1.75mm x 35mm Hex Head Bolts, (8) 12mm x 32mm OD x 3mm Flat Washers and (4)12mm Nylon Lock Nuts into the remaining holes in the Mounting Brackets, **(Figure 6)**. Use (2) 8mm x 20mm Button Head Allen Bolts, (4) 8mm x 22mm OD x 1.5mm Flat Washers and (2) 8mm Nylon Lock Nuts to fasten the Top Bracket to the Grille Guard, **(Figure 7)**. **IMPORTANT:** Slowly close the hood to check for clearance and fit of the Grille Guard and brackets. Adjust the Brackets as necessary then snug but do not tighten all of the hardware. Due to factory build variances in vehicles, it may be necessary to adjust the height of the front bumper to provide additional clearance for the Grille Guard Top Brackets. Loosen the bumper mounting hardware and adjust as necessary.

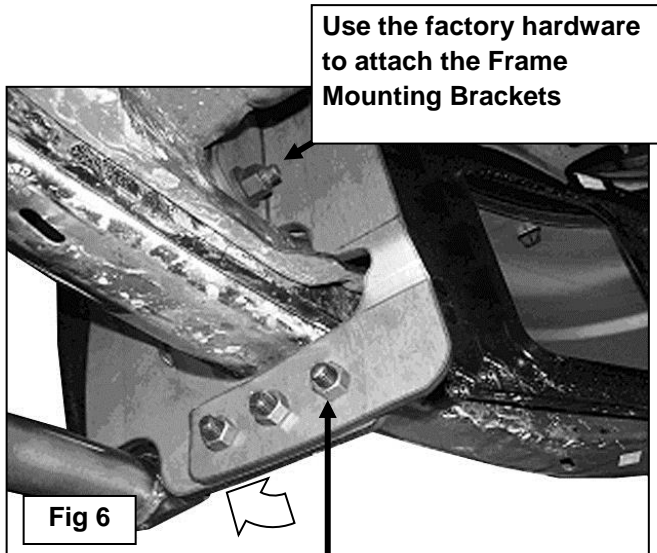

Fig 6

Use the factory hardware to attach the Frame Mounting Brackets

12mm x 35mm Hex Bolts  
12mm x 24mm OD x 2.5mm Flat Washers  
12mm Nylon Lock Nuts

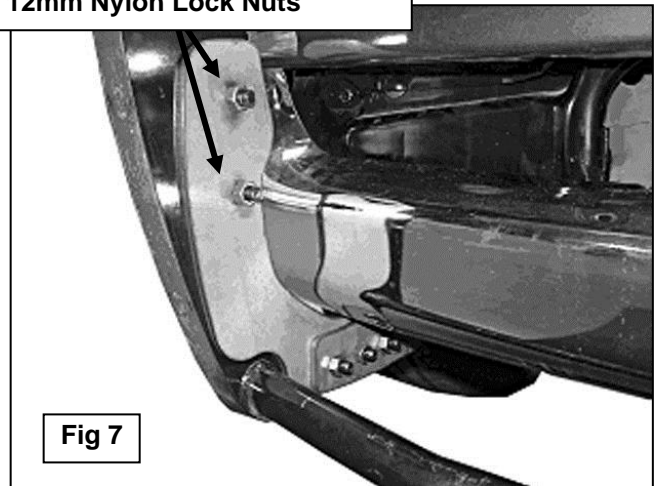

Fig 7

Start Grille Guard installation by inserting (1 per side) Hex Bolt with hardware in the rear-most mounting holes first to act as a hinge. Tilt the Grille Guard up into position and install remaining hardware

8. Stand back from the vehicle and check the Grille Guard alignment, for level and if it is centered and on the vehicle. Adjust as necessary. **IMPORTANT:** Once properly aligned, tighten only the hardware securing the Frame Mounting Brackets to the truck. Do not tighten the hardware on the Grille Guard. Leave the Frame Mounting Brackets and Top Brackets on the vehicle and remove the Grille Guard.
9. Next, hold the spoiler up to the bumper cover and align it with the mounting points. Mark the location of the Mounting Brackets onto the spoiler, **(Figure 8)**. Cut an approximately 1/2" wide slot in the lower portion of the spoiler to clear the Mounting Brackets. **NOTE:** The size of the slot is an estimate only and may vary due to different factory designs for the spoiler and front bumper covers. **IMPORTANT:** To maintain the integrity of the spoiler, do not cut the slot any larger than necessary. Do not cut through the mounting surface. It is recommended to make several small cuts and check the fit often for a clean installation.

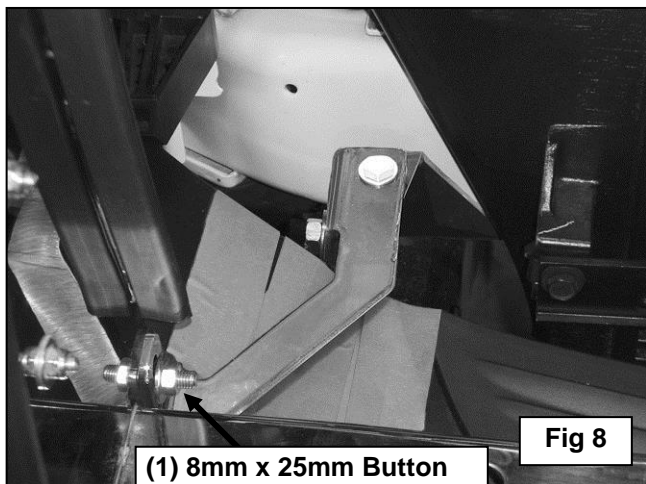
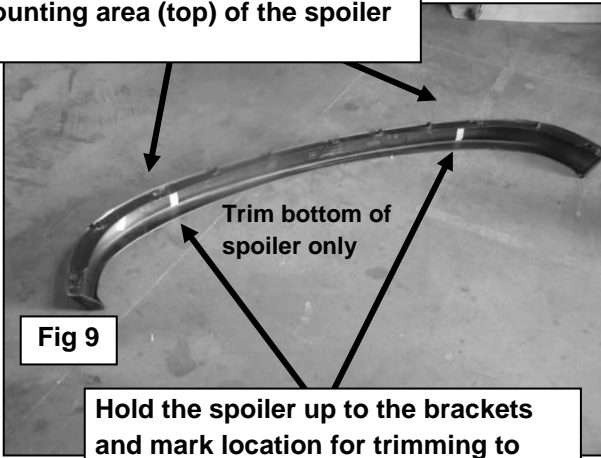

Fig 8

(1) 8mm x 25mm Button Head Allen Bolt  
(2) 8mm Flat Washers  
(1) 8mm Nylon Lock Nut

10. Once the final cuts have been made, re-install the spoiler using the factory hardware. It may be necessary to remove the Frame Mounting Brackets for more clearance to reinstall the spoiler.
11. Re-install, level and adjust the Grille Guard as described in Step # 8-9. Tighten all hardware.

**Warning: Do not cut through the mounting area (top) of the spoiler**



**Hold the spoiler up to the brackets and mark location for trimming to clear brackets. Cut only the material required to clear the brackets. To maintain strength, it is not necessary or recommended to cut through the mounting edge (top) of the spoiler**

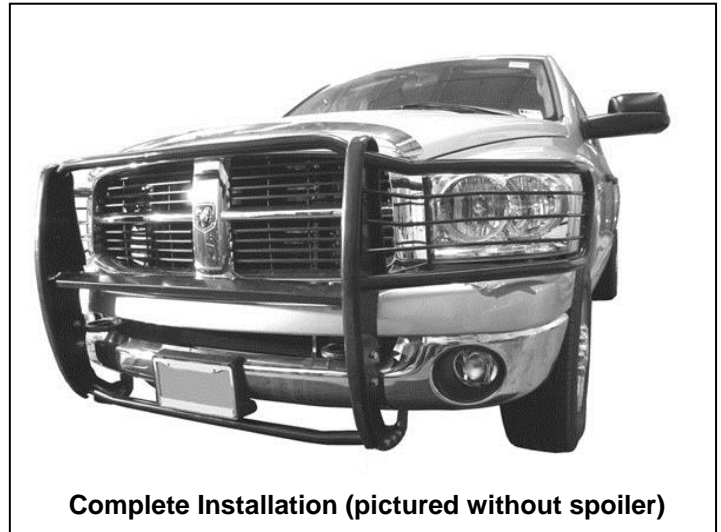

**Complete Installation (pictured without spoiler)**

**PRODUCT CARE**

- Periodically check the product to ensure all fasteners are tight and components are intact.
- Regular waxing is recommended to protect the finish of the product.
- **Use ONLY Non-Abrasive automotive wax.** Use of any soap, polish or wax that contains an abrasive is detrimental and can scratch the finish leading to corrosion.
- Aluminum polish may be used to polish small scratches and scuffs for **Stainless Steel finish.**
- Mild soap may be used to clean the product for both **Stainless Steel and Black finish.**

**FAQ's****1. Hardware's are not of correct size.**

*In GMC / Chevrolet truck model 2006 & up, customer needs to reuse the factory body bolts to install the bracket. If your vehicle is not GMC / Chevrolet 2006 & up, ensure that holes are not partially covered with any plastic grommet or rust? If it is, remove the plastic grommet & rust from the thread holes & re-try the installation.*

**2. Mounting Bracket are not getting Installed properly.**

*In some cases Illustration images shown in Installation manual may not be the exactly same as per actual vehicle images ,also if Driver / Passenger side mounting brackets are very identical in the design, suggest referring Parts Identification guide to avoid fitment issue.*

**3. Products are thumping / rattling after installation.**

*Ensure that all required mounting brackets / hardware's are installed & tighten correctly. Suggest using white lithium / regular grease between the metal to metal contact surfaces.*

**4. Side Bar is not aligning with vehicle / Step Pads are not aligning with vehicle doors.**

*Side bar may be interchanged or mounting brackets are not installed at the correct position in the vehicle. Refer Parts identification guide.*

**5. Missing / Excess Hardware.**

*Recheck hardware count as per the part list.*

**6. Product not installing properly.**

*Ensure make model year, cab length and bed size of your vehicle is listed in the application. All installation steps are followed correctly.*

Check out these other TrailFX Products!!

www.FX-Products.com



**SIDE BAR**

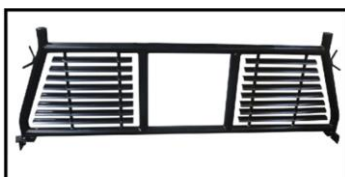

**HEADACHE RACKS**

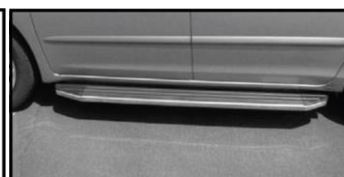

**RUNNING BOARDS**



**ROCKER GUARDS**

Keystone Automotive Operations Inc. (KAO) warrants this product to be free of defects in material and workmanship at the time of purchase by the original retail consumer. KAO disclaims any other warranties, express or implied, including the warranty of fitness for a particular purpose or an intended use. If the product is found to be defective, KAO may replace or repair the product at our option, when the product is returned prepaid, with proof of purchase. Alteration to, improper installation, or misuse of this product voids the warranty. KAO's liability is limited to repair or replacement of products found to be defective, and specifically excludes liability for any incidental or consequential loss or damage.