



Grille Guard

Part No.81200/81201



Fits: 2007-2013

Chevrolet Silverado 1500 LD



THE GRILLE GUARD MAY INTERFERE WITH PARKING SENSORS, PROXIMITY SENSORS AND CRUISE CONTROL SENSORS.



REMOVE CONTENTS FROM BOX. VERIFY ALL PARTS ARE PRESENT.



READ INSTRUCTIONS CAREFULLY BEFORE STARTING INSTALLATION.

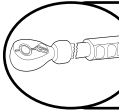

DO NOT OVER TORQUE. STANDARD OPERATING LOAD FOR TIGHTEN BODY MOUNT NUTS & BOLTS VARIES FROM 45 TO 65 FOOT POUND.



60-180 min

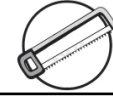

Cutting Is Required



Drilling Not Required



support@trailfx.com



1 866 638 4870



POLISHED STAINLESS STEEL – LIMITED LIFETIME
POWDER COATED BLACK – 3 YEARS

PARTS LIST:

Qty	Part Description	Qty	Part Description
1	Grille Guard	10	12mm x 24mm OD x 2.5mm STD Flat Washers
1	Driver/Left Top Bracket	12	12mm x 32mm OD x 3mm Large Flat Washers
1	Passenger/Right Top Bracket	12	12mm Nylon Lock Nuts
2	Frame Mounting Brackets	2	10-1.50mm x 25mm Button Head Bolts
2	Lower Frame Support Brackets	4	10mm x 20mm x 2mm Flat Washers
2	12-1.75mm x 40mm Bolt Plates (#11)	2	10mm Nylon Lock Nuts
2	12mm Plastic Retainers	2	600mm x 50mm x 1.0mm Adhesive Backed Foam Tape
2	12-1.75mm x 140mm Hex Bolts	1	6mm Allen Wrench
8	12-1.75mm x 30mm Hex Bolts		

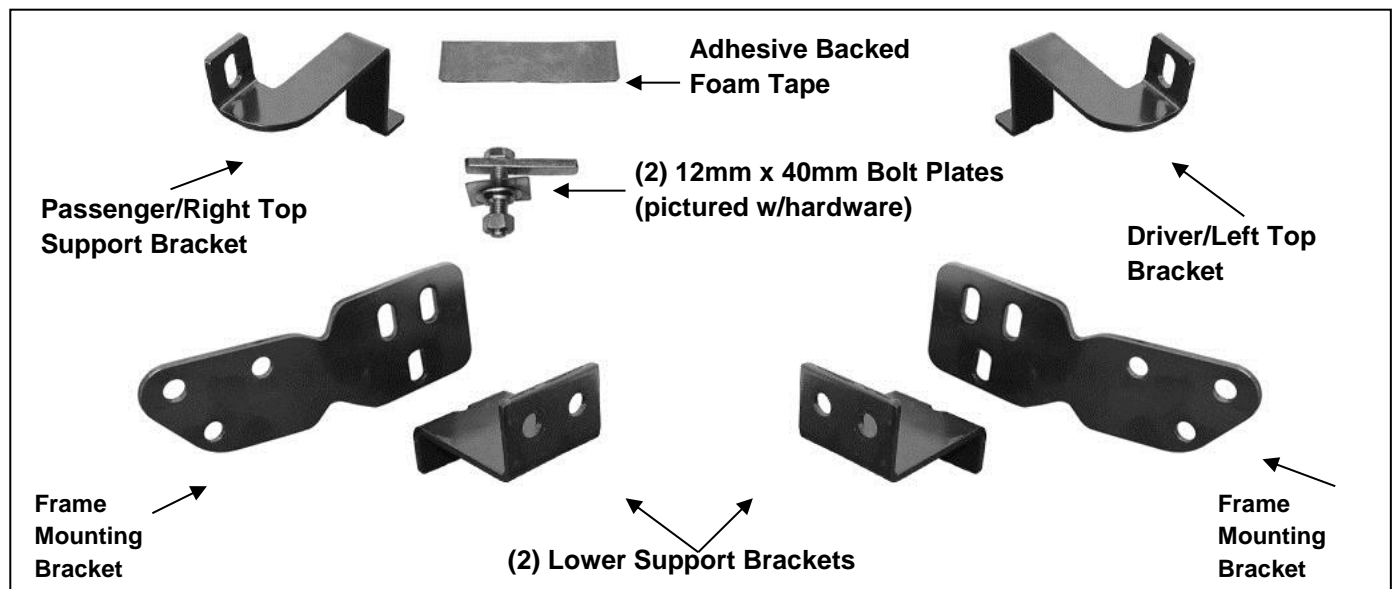

INSTALLATION PROCEDURE:

1. **DO NOT ATTEMPT INSTALLATION ALONE; PERSONAL INJURY OR DAMAGE TO THE VEHICLE MAY RESULT. CUTTING IS REQUIRED.**
2. Start installation from under the front of the vehicle. Determine if the vehicle is equipped with tow hooks.
 - a. **Vehicles equipped with tow hooks and/or openings in bumper cover:** Remove the factory tow hooks, if equipped, **(Figure 1)**. **NOTE:** This Grille Guard is not compatible with factory tow hooks.
 - b. **Vehicles without tow hooks and no openings in bumper cover:** Remove the plastic lower bumper cover. Place bumper cover on a clean, stable work surface, **(Figure 2)**.
3. Locate the (2) holes, side by side, in the forward end of each frame channel. Insert (1) Bolt Plate into the open end of the frame channel and out the rearmost hole in the side of the frame, **(Figure 3)**. Thread (1) 12mm Plastic Retainer onto the threaded end of the Bolt Plate to hold the Bolt Plate in position during Bracket installation, **(Figure 4)**.
 - a. **On the passenger side**, the (2) holes are on the outer wall of the frame rail, **(Figures 3, 4 & 7A)**.
 - b. **On the driver side**, the (2) holes will be on the inner wall of the frame, **(Figure 8B)**.
4. Select (1) Mounting Bracket and (1) Support Bracket. **NOTE, on vehicles with openings in bumper cover**, it may be necessary to enlarge the (2) openings in the bumper cover slightly to clear the Mounting Brackets, **(Figure 6)**. Trim cover as required to install Brackets.
 - a. **Passenger/Right side Mounting Bracket installation:** Secure the Mounting Bracket to the Bolt Plate with (1) 12mm x 24mm STD Flat Washer and (1) 12mm Nylon Lock Nut. Select (1) Lower Support Bracket. Line up the forward hole in the Support Bracket with the hole in the inner wall of the frame channel. Insert (1) 12mm x 140mm Long Hex Bolt and (1) 12mm x 24mm STD Flat Washer through the Support Bracket, both sides of the frame channel and out the remaining hole in the Mounting Bracket, **(Figures 5, 7A & 7B)**. Secure with the included (1) 12mm x 24mm STD Flat Washer and (1) 12mm Nylon Lock Nut.

Line up the hole in the bottom of the Support Bracket with the lower hole in the Mounting Bracket. Bolt the (2) Brackets together with the included (1) 12mm x 30mm Hex Bolt, (2) 12mm x 24mm STD Flat Washers and (1) 12mm Nylon Lock Nut, **(Figures 7A & 7B)**. Do not fully tighten hardware.
 - b. **Driver/Left side Mounting Bracket installation:** Select (1) Lower Support Bracket. Line up the rear hole in the Support Bracket with the previously installed Bolt Plate. Secure the Support Bracket to the Bolt Plate with (1) 12mm x 24mm STD Flat Washer and (1) 12mm Nylon Lock Nut, **(Figures 8A & 8B)**. Do not tighten at this time.

Select (1) Mounting Bracket. Insert (1) 12mm x 140mm Long Hex Bolt and (1) 12mm x 24mm STD Flat Washer through the forward hole in the Support Bracket, both sides of the frame channel and out the forward hole in the Mounting Bracket, **(Figures 8A & 8B)**. Secure the Mounting Bracket with the included (1) 12mm x 24mm STD Flat Washer and (1) 12mm Nylon Lock Nut.

Bolt the bottom of the Support Bracket to the Mounting Bracket as previously described in **Step 4a**, **(Figures 8A & 8B)**. Do not fully tighten hardware.
5. Next, open the hood and remove the plastic cover between the top of the grille and the radiator. **NOTE:** Use a small flat head screw driver to pop up the center of the plastic clips. Remove the two outer bolts from the grille shell. Use a pair of "needle nose" pliers to carefully squeeze the back of the clips to release as you gently pull the grill forward, **(Figure 9)**. **IMPORTANT:** Do not damage the clips holding the grille in place. Once all of the clips have been released, carefully remove the grille by gently pulling it forward from the vehicle
6. Remove the long factory top bumper bracket bolt behind the bumper on the top of the frame. Select the driver side Top Bracket. Apply a layer of Adhesive Backed Foam Tape to the inside of the Bracket to protect the finish on the bumper, **(Figure 10)**. **IMPORTANT:** To prevent the Top Brackets from damaging the finish on the vehicle during installation, cover the top of the bumper with removable tape, (masking tape). Secure the Top Bracket to the bumper bracket with the factory hex bolt, **(Figure 11)**. Leave the hardware loose at this time. Repeat this Step to install the passenger side Top Bracket.
7. With assistance, hold the Grille Guard up in position on the outside of the Mounting Brackets. Bolt the Grille Guard to the Brackets with (6) 12mm x 30mm Hex Bolts, (12) 12mm x 32mm Large Flat Washers and (6) 12mm Nylon Lock Nuts, **(Figures 7A & 8B)**. Snug but do not tighten hardware at this time.
8. Line up the driver side Top Bracket with the hole in the upright on the Grille Guard. Bolt the Top Bracket to the upright with (1) 10mm Button Head Bolt, (2) 10mm Flat Washers and (1) 10mm Nylon Lock Nut, **(Figure 12)**. Do not tighten hardware at this time. Repeat for passenger side Top Bracket installation.
9. Level and adjust the Grille Guard. Make sure that the Top Brackets do not come in contact with the top of the bumper cover.
 - a. **Vehicles equipped with tow hooks and/or opening in bumper cover:** Proceed to tighten all hardware.

b. Vehicles without tow hooks and no openings in bumper cover: Tighten the lower Mounting Bracket hardware only. Temporarily remove the Grille Guard. Hold the lower bumper cover up in position and mark the location of the Mounting Brackets onto the back of the cover. Cut the Grille Guard to clear the Brackets. Reinstall the bumper cover over the Brackets. Reinstall the Grille Guard as described in **Steps 7 – 8**. Level and adjust the Grille Guard and tighten all hardware at this time.

10. Once all mounting hardware is tight, line up the clips on the grille with the mounting tabs, (**Step 5**), and gently push the grille back into place. Reinstall the top plastic cover.

11. Do periodic inspections to the installation to make sure that all hardware is secure and tight.

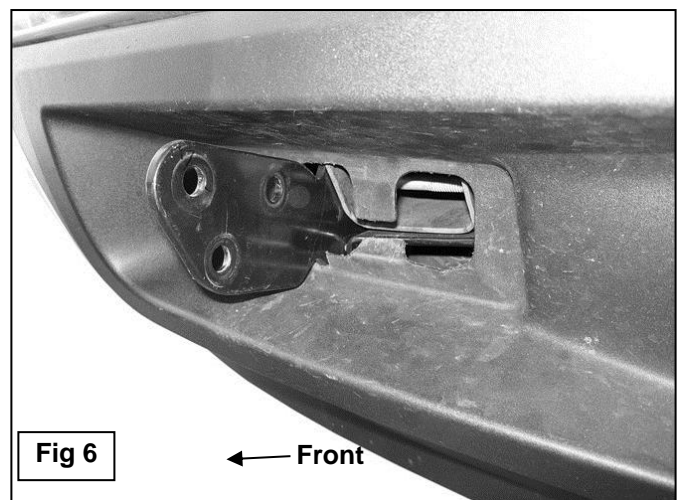
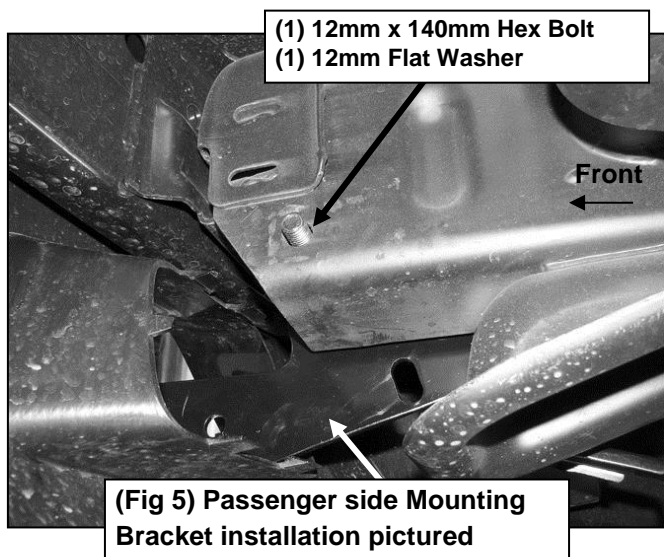
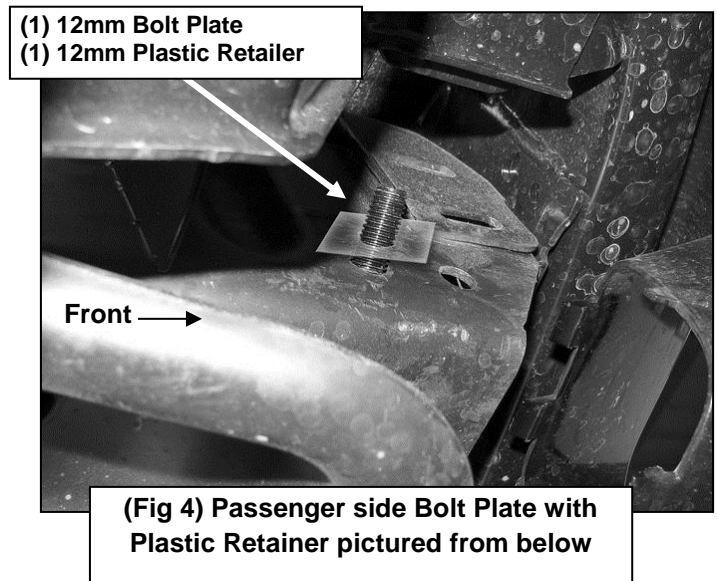
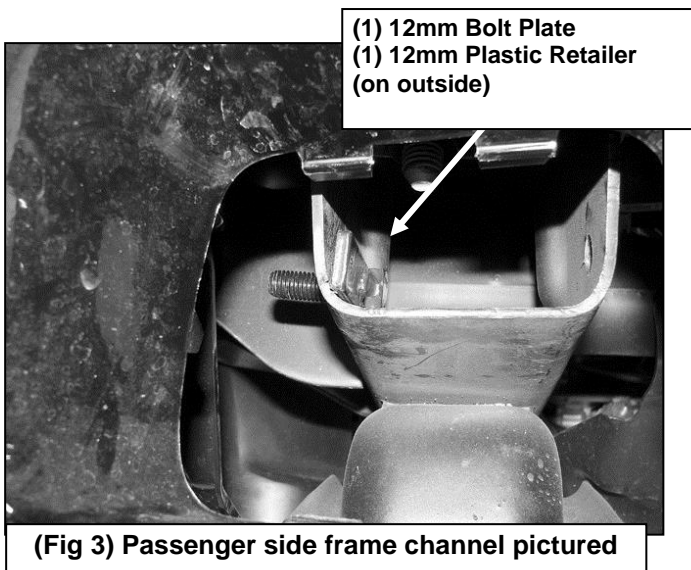
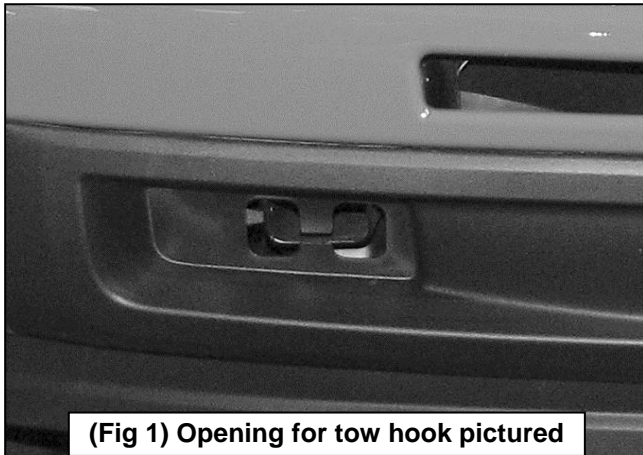

Passenger Side Mounting Bracket Installation Pictured

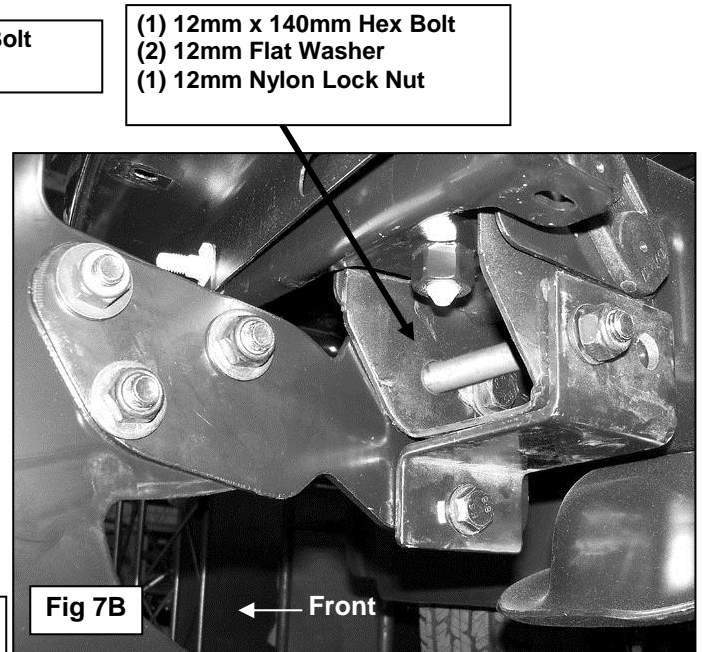
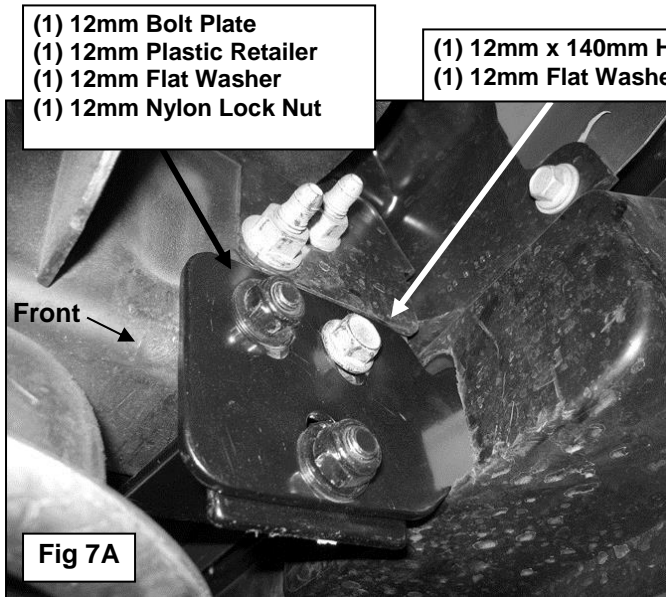

Driver Side Mounting Bracket Installation Pictured

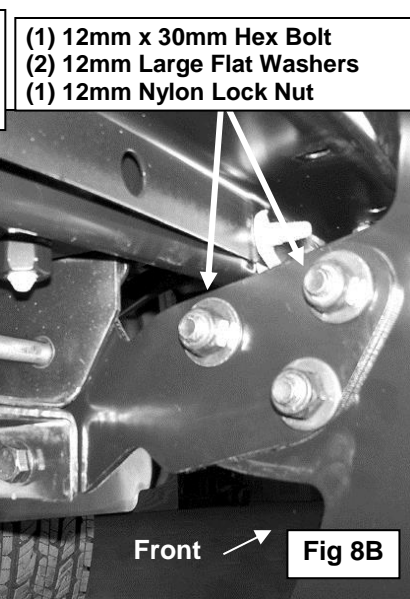
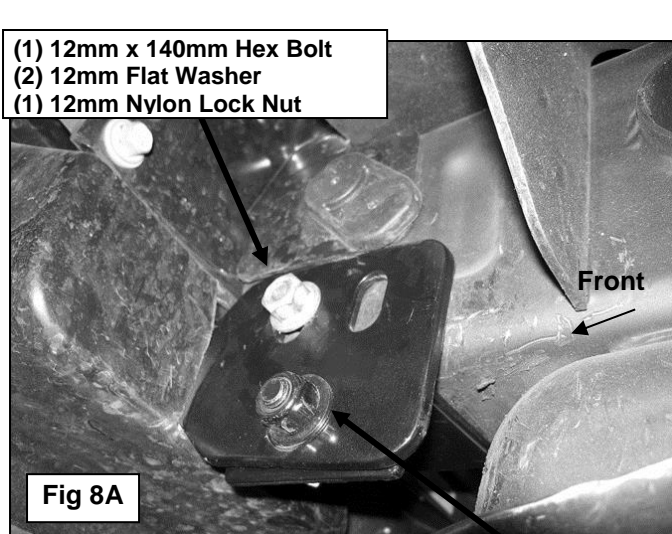

Driver Side Mounting Bracket Installation Pictured

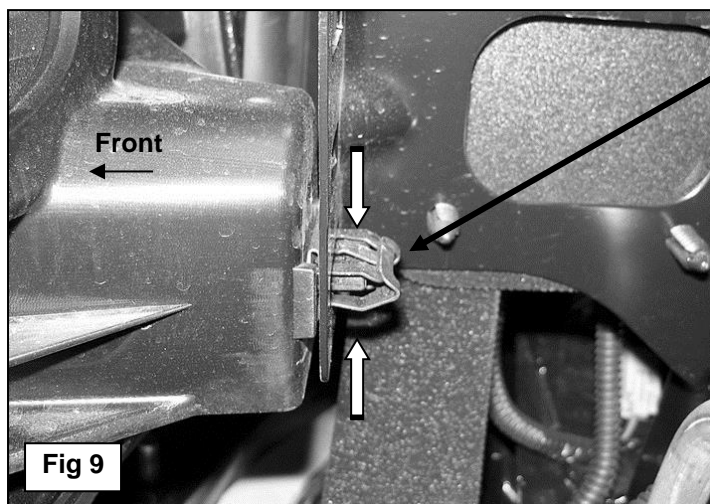

Use a pair of needle nose pliers to carefully pinch the top and bottom tab on the clip to release and remove the grille

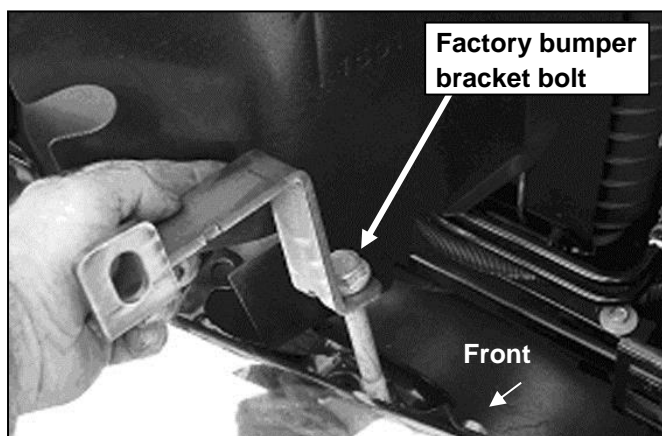
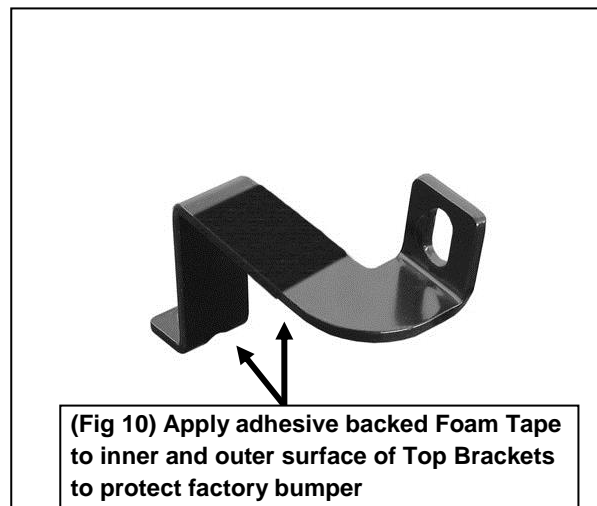

- (1) 10mm Button Head Bolt
- (2) 10mm Flat Washers
- (1) 10mm Nylon Lock Nut

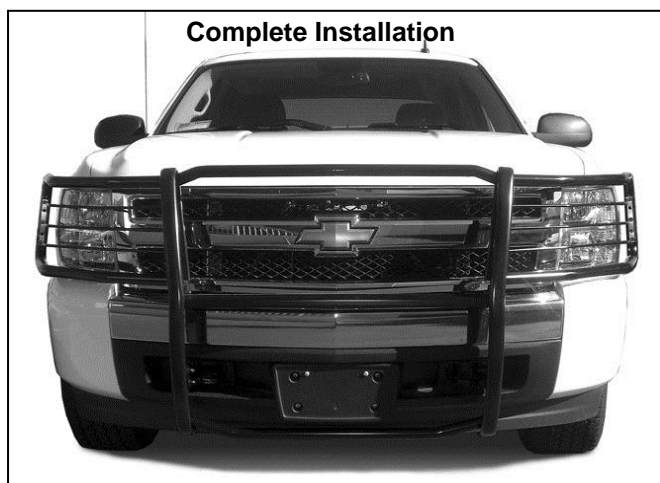
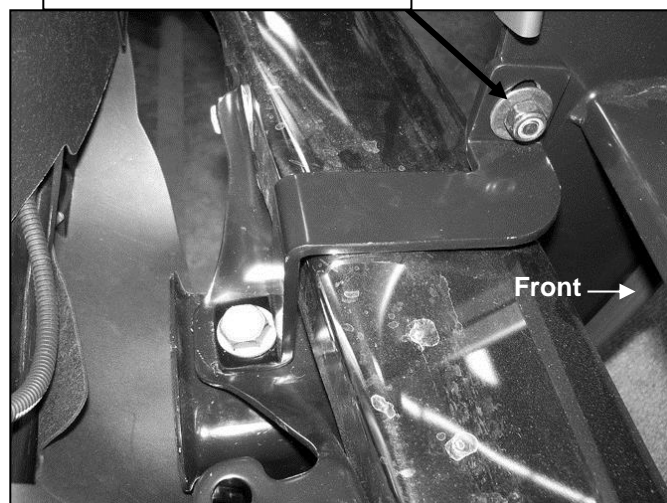

PRODUCT CARE

- Periodically check the product to ensure all fasteners are tight and components are intact.
- Regular waxing is recommended to protect the finish of the product.
- **Use ONLY Non-Abrasive automotive wax.** Use of any soap, polish or wax that contains an abrasive is detrimental and can scratch the finish leading to corrosion.
- Aluminum polish may be used to polish small scratches and scuffs for **Stainless Steel finish.**
- Mild soap may be used to clean the product for both **Stainless Steel and Black finish.**

FAQ's**1. Hardware's are not of correct size.**

In GMC / Chevrolet truck model 2006 & up, customer needs to reuse the factory body bolts to install the bracket. If your vehicle is not GMC / Chevrolet 2006 & up, ensure that holes are not partially covered with any plastic grommet or rust? If it is, remove the plastic grommet & rust from the thread holes & re-try the installation.

2. Mounting Bracket are not getting Installed properly.

In some cases Illustration images shown in Installation manual may not be the exactly same as per actual vehicle images ,also if Driver / Passenger side mounting brackets are very identical in the design, suggest referring Parts Identification guide to avoid fitment issue.

3. Products are thumping / rattling after installation.

Ensure that all required mounting brackets / hardware's are installed & tighten correctly. Suggest using white lithium / regular grease between the metal to metal contact surfaces.

4. Side Bar is not aligning with vehicle / Step Pads are not aligning with vehicle doors.

Side bar may be interchanged or mounting brackets are not installed at the correct position in the vehicle. Refer Parts identification guide.

5. Missing / Excess Hardware.

Recheck hardware count as per the part list.

6. Product not installing properly.

Ensure make model year, cab length and bed size of your vehicle is listed in the application. All installation steps are followed correctly.

Check out these other TrailFX Products!!

www.TrailFX.com



BULL BAR



GRILLE GUARDS



BED RAILS



RUNNING BOARDS

Keystone Automotive Operations Inc. (KAO) warrants this product to be free of defects in material and workmanship at the time of purchase by the original retail consumer. KAO disclaims any other warranties, express or implied, including the warranty of fitness for a particular purpose or an intended use. If the product is found to be defective, KAO may replace or repair the product at our option, when the product is returned prepaid, with proof of purchase. Alteration to, improper installation, or misuse of this product voids the warranty. KAO's liability is limited to repair or replacement of products found to be defective, and specifically excludes liability for any incidental or consequential loss or damage.