



Grille Guard

Part No.81100/81101



Fits: **2003-2005**

Dodge Ram 1500/2500/3500



THE GRILLE GUARD MAY INTERFERE WITH PARKING SENSORS, PROXIMITY SENSORS AND CRUISE CONTROL SENSORS.



REMOVE CONTENTS FROM BOX. VERIFY ALL PARTS ARE PRESENT.



READ INSTRUCTIONS CAREFULLY BEFORE STARTING INSTALLATION.

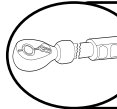

DO NOT OVER TORQUE. STANDARD OPERATING LOAD FOR TIGHTEN BODY MOUNT NUTS & BOLTS VARIES FROM **45 TO 65** FOOT POUND.



60-180 min

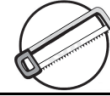

Cutting May be Required



Drilling Not Required



support@trailfx.com



1 866 638 4870



POLISHED STAINLESS STEEL – LIMITED LIFETIME
POWDER COATED BLACK – 3 YEARS

PARTS LIST:

Qty	Part Description	Qty	Part Description
1	Grille Guard	6	12-1.75mm Nylon Lock Nuts
1	Driver/Left Frame Mounting Bracket	8	10-1.5mm x 40mm Hex Bolts (Gr 10.9)
1	Passenger/Right Frame Mounting Bracket	16	10mm x 24mm OD x 2.2mm Flat Washers
6	12-1.75mm x 35mm Hex Bolts	8	10mm Nylon Lock Nuts
12	12mm x 24mm OD x 2.5mm Flat Washers		

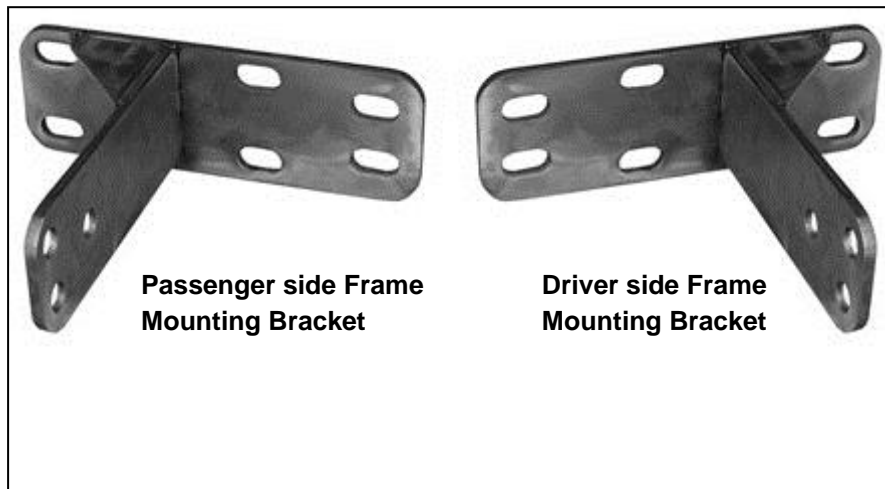

Passenger side Frame Mounting Bracket

Driver side Frame Mounting Bracket

INSTALLATION PROCEDURE:

1. **ASSISTANCE IS RECOMMENDED. VERIFY ALL PARTS ARE PRESENT. READ INSTRUCTION TOW HOOKS (IF EQUIPPED) CANNOT BE RE-INSTALLED WITH THIS GRILLE GUARD. CUTTING MAY BE REQUIRED.**
2. Remove the tow hooks, (25-3500, **Figure 4**), or tow hook and bracket, (1500), if equipped. On models without tow hooks, remove the plastic insert in the center of the bumper below the grill, (**Figure 1**). **NOTE:** From behind the bumper, push the plastic center pin down to release the 2-piece clips. Do not pry up on the head of the clip. Take care to avoid damage to the clips and/or plastic cover.
3. Determine the correct step for your application:

On 1500 Models:

Select the driver side Frame Mounting Bracket, (**Figure 2**). Line up the mounting holes in the Bracket with the (3) mounting holes on the mounting plate on the end of the frame behind the bumper, (**Figure 3A**). Bolt the Bracket to the frame with (3) 10mm x 40mm Hex Bolts, (6) 10mm Flat Washers and (3) 10mm Nylon Lock Nuts, (**Figure 3B**). **NOTE:** Access the back of the mounting location from behind the bumper bracket. **NOTE:** Factory tow hook hardware may also be re-used with the included 10mm Flat Washers installed between Bracket and hex bolt, (**Figure 3B**). Do not tighten hardware.

On 25-3500 Models:

Select the driver side Frame Bracket, (**Figure 5**). Bolt the Bracket to the (4) holes in the end of the frame with the supplied (4) 10mm x 40mm Hex Bolts, (8) 10mm Flat Washers and (4) 10mm Nylon Lock Nuts, (**Figures 6A & 6B**). **NOTE:** Factory tow hook hardware may also be re-used with the included 10mm Flat Washers installed between Bracket and hex bolt, (**Figure 7**). Do not tighten hardware.

4. Repeat the correct previous Step to install the passenger side frame mounting Bracket.
5. With assistance, lift the Grille Guard up to the outside of the Frame Mounting Brackets. Bolt the Grille Guard to the Brackets with (6) 12mm x 35mm Hex Bolts, (12) 12mm Flat Washers and (6) 12mm Nylon Lock Nuts, (**Figure 7**). **IMPORTANT:** Slowly close the hood to check for clearance and fit of the Grille Guard and Brackets. Adjust as necessary then snug but do not fully tighten all of the hardware.
6. Stand back from the vehicle and check to see that the Grille Guard is centered and level on the vehicle and adjust as necessary. **IMPORTANT:** Once properly aligned, fully tighten all hardware.
7. Do periodic inspections of the installation to make sure that all hardware is secure and tight.
8. **Optional:** If the vehicle was not equipped with tow hooks and you removed the plastic cover detailed in **Step 2**, it may be reinstalled once the Grille Guard is properly adjusted but will require cutting. Trim from each end until the cover fits between the Frame Mounting Brackets. Line up the mounting holes and secure the cover with the factory clips by pushing the outer socket into place then inserting the center pin.

Ram 1500 Series Driver Side Installation Pictured

Remove plastic cover to access mounting locations



1500 mounting holes

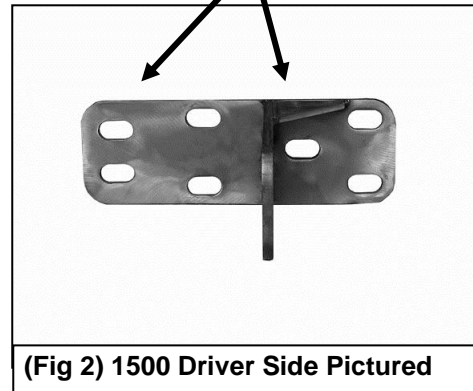

- (3) 10mm x 40mm Hex Bolts
- (6) 10mm Flat Washers
- (3) 10mm Nylon Lock Nuts

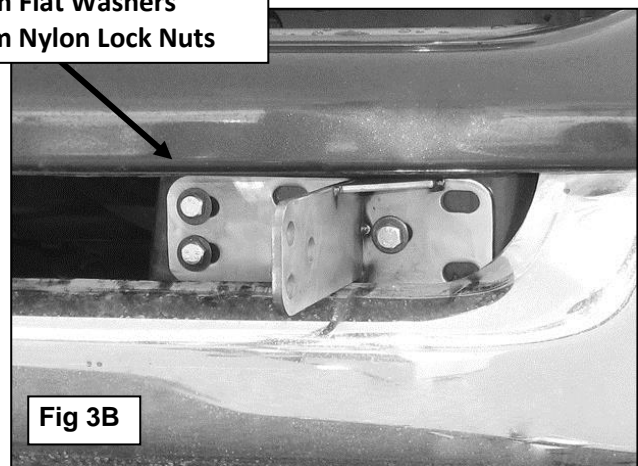
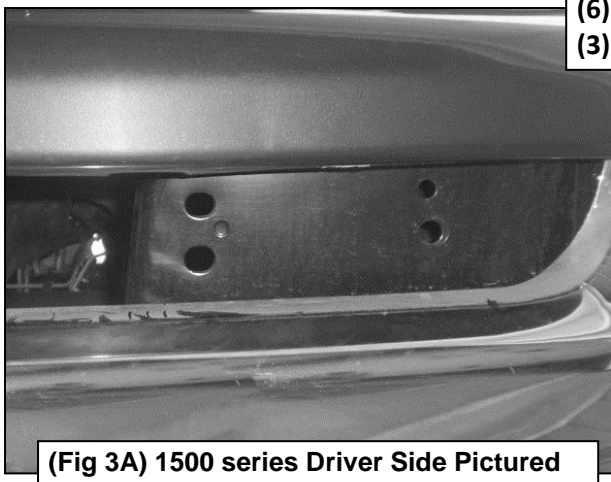

Ram 25-3500 Series Driver Side Installation Pictured

Remove factory tow hooks if equipped

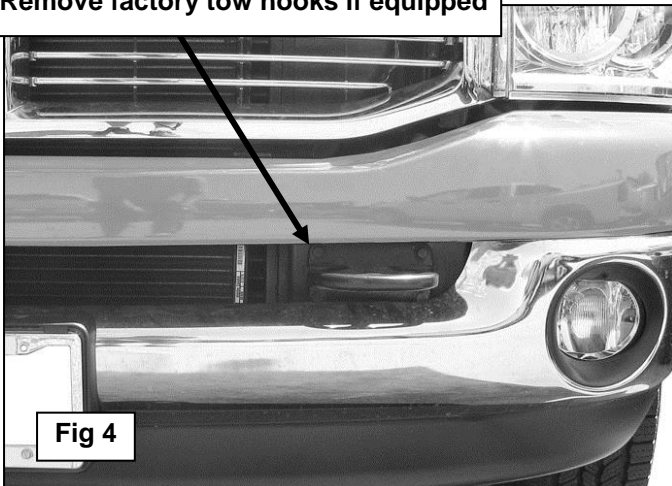

25-3500 mounting holes

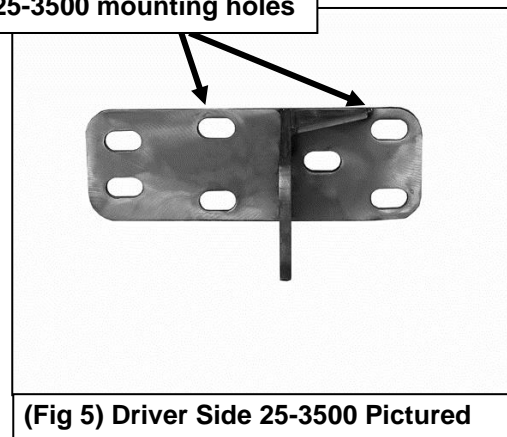

Ram 25-3500 Series Driver Side Installation Pictured



(Fig 6A) 25-3500 Driver Side Pictured

- (4) 10mm x 40mm Hex Bolts
- (8) 10mm Flat Washers
- (4) 10mm Nylon Lock Nuts

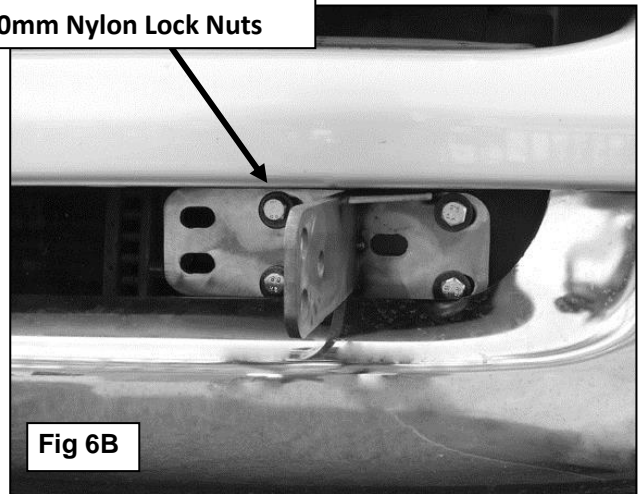

Fig 6B

- (3) 12mm x 35mm Hex Bolts
- (6) 12mm Flat Washers
- (3) 12mm Nylon Lock Nuts

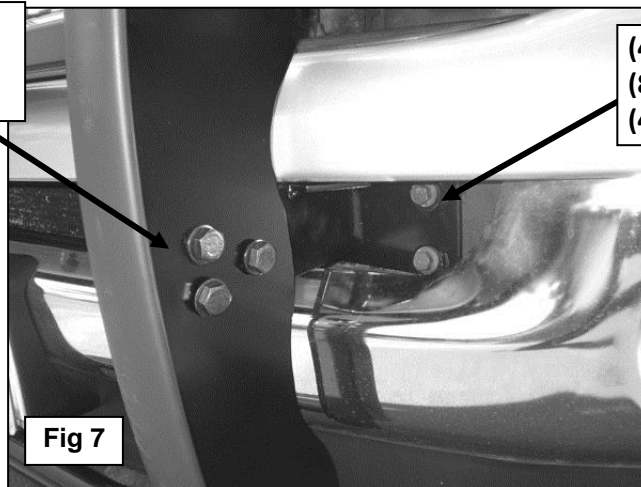

Fig 7

- (4) 10mm x 40mm Hex Bolts
- (8) 10mm Flat Washers
- (4) 10mm Nylon Lock Nuts



Complete Installation

PRODUCT CARE

- Periodically check the product to ensure all fasteners are tight and components are intact.
- Regular waxing is recommended to protect the finish of the product.
- **Use ONLY Non-Abrasive automotive wax.** Use of any soap, polish or wax that contains an abrasive is detrimental and can scratch the finish leading to corrosion.
- Aluminum polish may be used to polish small scratches and scuffs for **Stainless Steel finish.**
- Mild soap may be used to clean the product for both **Stainless Steel and Black finish.**

FAQ's**1. Hardware's are not of correct size.**

In GMC / Chevrolet truck model 2006 & up, customer needs to reuse the factory body bolts to install the bracket. If your vehicle is not GMC / Chevrolet 2006 & up, ensure that holes are not partially covered with any plastic grommet or rust? If it is, remove the plastic grommet & rust from the thread holes & re-try the installation.

2. Mounting Bracket are not getting Installed properly.

In some cases Illustration images shown in Installation manual may not be the exactly same as per actual vehicle images ,also if Driver / Passenger side mounting brackets are very identical in the design, suggest referring Parts Identification guide to avoid fitment issue.

3. Products are thumping / rattling after installation.

Ensure that all required mounting brackets / hardware's are installed & tighten correctly. Suggest using white lithium / regular grease between the metal to metal contact surfaces.

4. Side Bar is not aligning with vehicle / Step Pads are not aligning with vehicle doors.

Side bar may be interchanged or mounting brackets are not installed at the correct position in the vehicle. Refer Parts identification guide.

5. Missing / Excess Hardware.

Recheck hardware count as per the part list.

6. Product not installing properly.

Ensure make model year, cab length and bed size of your vehicle is listed in the application. All installation steps are followed correctly.

Check out these other TrailFX Products!!

www.TrailFX.com



SIDE BAR

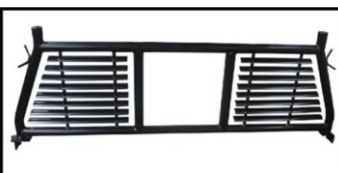

HEADACHE RACKS

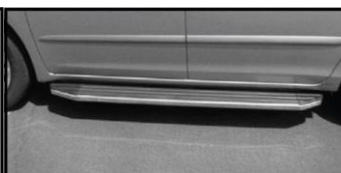

RUNNING BOARDS



ROCKER GUARDS

Keystone Automotive Operations Inc. (KAO) warrants this product to be free of defects in material and workmanship at the time of purchase by the original retail consumer. KAO disclaims any other warranties, express or implied, including the warranty of fitness for a particular purpose or an intended use. If the product is found to be defective, KAO may replace or repair the product at our option, when the product is returned prepaid, with proof of purchase. Alteration to, improper installation, or misuse of this product voids the warranty. KAO's liability is limited to repair or replacement of products found to be defective, and specifically excludes liability for any incidental or consequential loss or damage.