

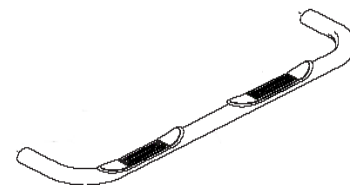

3" Nerf Bar

Part No. 1112190021 /1112190023



Fits: 2004-2012

Chevrolet Colorado / GMC Canyon Crew Cab



REMOVE CONTENTS FROM BOX. VERIFY ALL PARTS ARE PRESENT.



READ INSTRUCTIONS CAREFULLY BEFORE STARTING INSTALLATION.

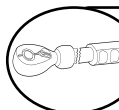

DO NOT OVER TORQUE. STANDARD OPERATING LOAD FOR TIGHTEN BODY MOUNT NUTS & BOLTS VARIES FROM 45 TO 65 FOOT POUND.



60-180 min



Cutting Not Required



Drilling Not Required



support@trailfx.com



1 866 638 4870



POLISHED STAINLESS STEEL – LIMITED LIFETIME
POWDER COATED BLACK – 3 YEARS

PARTS LIST:

Qty	Part Description	Qty	Part Description
2	Side Tubes With Steps	16	M8 – 1.25 X 30mm Hex Head Bolt
2	Front Mount Brackets	16	M8 Split Lock Washer
2	Rear Mount Brackets	20	M8 Flat Washer
4	Mount Braces	8	3/8" – 16 X 1.00" Button Head Cap Screw
4	M8 – 1.25 Hex Nut	8	3/8" – Split Lock Washer

INSTALLATION PROCEDURE

1. Begin installation by working on driver side of the vehicle (refer to Figures 1. 1- 1.3)
2. Install Mount Brackets to vehicle body posts using (2) M8 – 1.25 x 30mm hex head bolts, (2) M8 split lock washers, and (2) M8 flat washers, in that order. Hand tighten.
3. Fasten Mount Brace to inside rocker panel using (1) M8 – 1.25 x 30mm hex head bolt, (1) M8 split lock washer, and (1) M8 flat washer. Attach other end of Mount Brace to Mount Bracket using (1) M8 – 1.25 x 30mm hex head bolt, (2) M8 flat washers, (1) M8 split lock washer, and (1) M8 – 1.25 hex nut. Hand tighten.
4. Position Side Tube in place and fasten to Mount Brackets using (4) 3/8" – 16 x 1.00" button head cap screws and (4) 3/8" split lock washers. Hand tighten.
5. Level and adjust Side Tube as desired and adjust Mount Brackets to ensure a solid fit. Torque 8mm hardware to 25 FT-LBS and 3/8" hardware to 30 FT-LBS.
6. Repeat process for passenger side of vehicle to complete installation.

Figure 1.1 - Front Driver-Side View

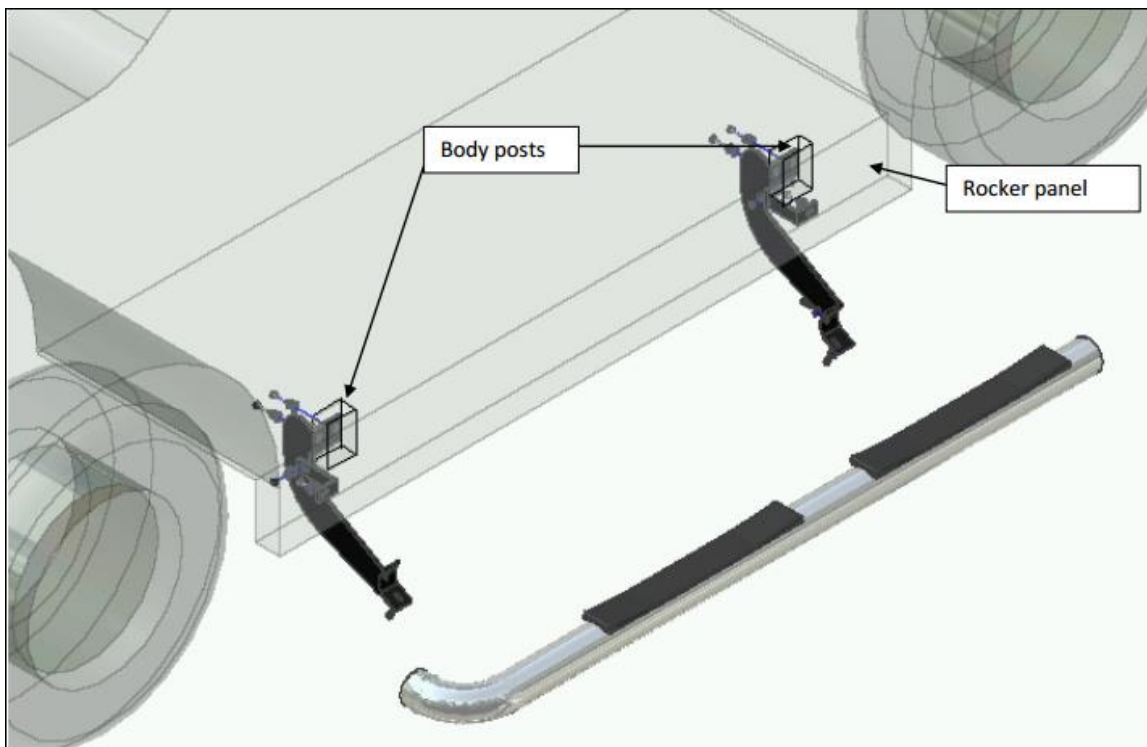

Figure 1.2 - Front Bracket

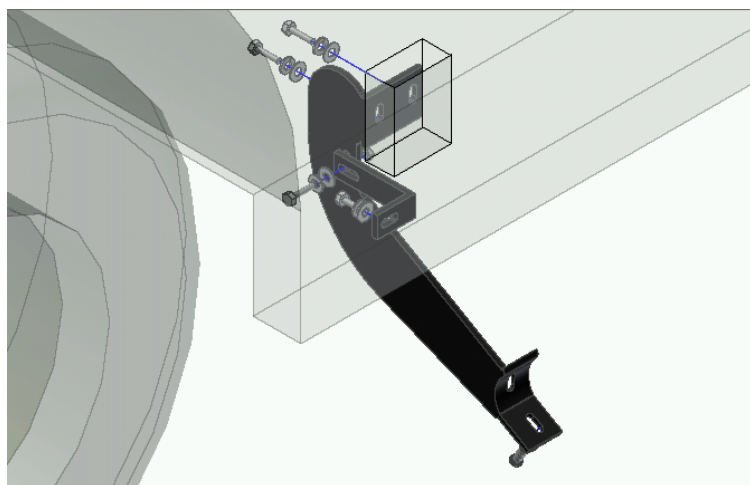
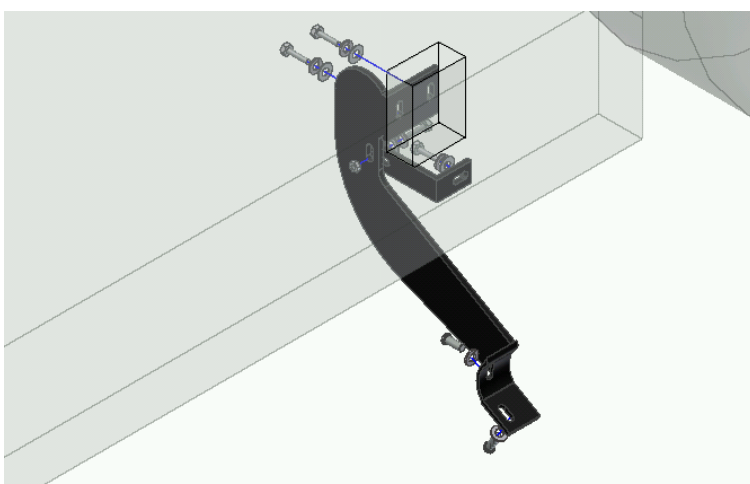

Figure 1.3 - Rear Bracket



No.	Parts Identification
1	Passenger / Right 'Rear' Bracket marked "PR"
2	Driver / Left 'Rear' Bracket marked "DR"
3	Passenger / Right 'Center' Bracket marked "PC"
4	Driver / Left 'Center' Bracket marked "DC"
5	Passenger / Right 'Front' Bracket marked "PF"
6	Driver / Left 'Front' Bracket marked "DF"

Note:

- This guide is to identify the parts and not a reference for part count.
- For part count, refer Parts List.
- Product / Bracket image is representative and actual design may vary.

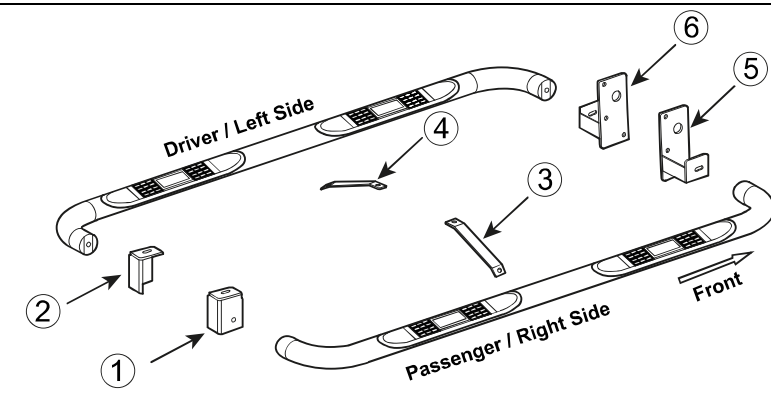

PRODUCT CARE

- Periodically check the product to ensure all fasteners are tight and components are intact.
- Regular waxing is recommended to protect the finish of the product.
- **Use ONLY Non-Abrasive automotive wax.** Use of any soap, polish or wax that contains an abrasive is detrimental and can scratch the finish leading to corrosion.
- Aluminum polish may be used to polish small scratches and scuffs for **Stainless Steel finish.**
- Mild soap may be used to clean the product for both **Stainless Steel and Black finish.**

FAQ's

- 1. Hardware's are not of correct size.**
In GMC / Chevrolet truck model 2006 & up, customer needs to reuse the factory body bolts to install the bracket. If your vehicle is not GMC / Chevrolet 2006 & up, ensure that holes are not partially covered with any plastic grommet or rust? If it is, remove the plastic grommet & rust from the thread holes & re-try the installation.
- 2. Mounting Bracket are not getting Installed properly.**
In some cases Illustration images shown in Installation manual may not be the exactly same as per actual vehicle images ,also if Driver / Passenger side mounting brackets are very identical in the design, suggest referring Parts Identification guide to avoid fitment issue.
- 3. Products are thumping / rattling after installation.**
Ensure that all required mounting brackets / hardware's are installed & tighten correctly. Suggest using white lithium / regular grease between the metal to metal contact surfaces.
- 4. Side Bar is not aligning with vehicle / Step Pads are not aligning with vehicle doors.**
Side bar may be interchanged or mounting brackets are not installed at the correct position in the vehicle. Refer Parts identification guide.
- 5. Missing / Excess Hardware.**
Recheck hardware count as per the part list.
- 6. Product not installing properly.**
Ensure make model year, cab length and bed size of your vehicle is listed in the application. All installation steps are followed correctly.

Check out these other TrailFX Products!!

www.TrailFX.com



Keystone Automotive Operations Inc. (KAO) warrants this product to be free of defects in material and workmanship at the time of purchase by the original retail consumer. KAO disclaims any other warranties, express or implied, including the warranty of fitness for a particular purpose or an intended use. If the product is found to be defective, KAO may replace or repair the product at our option, when the product is returned prepaid, with proof of purchase. Alteration to, improper installation, or misuse of this product voids the warranty. KAO's liability is limited to repair or replacement of products found to be defective, and specifically excludes liability for any incidental or consequential loss or damage.