

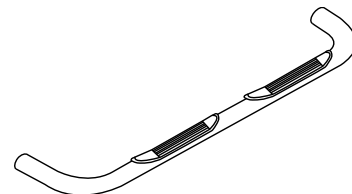

3" Side Bar

Part No. 1130360011/3



Fits: **2001–2006 Ford Explorer Sport Track**



REMOVE CONTENTS FROM BOX. VERIFY ALL PARTS ARE PRESENT.



READ INSTRUCTIONS CAREFULLY BEFORE STARTING INSTALLATION.

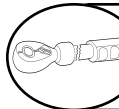

DO NOT OVER TORQUE. STANDARD OPERATING LOAD FOR TIGHTEN BODY MOUNT NUTS & BOLTS VARIES FROM 45 TO 65 FOOT POUND.



30-60 min

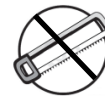

Cutting Not Required



Drilling Not Required



support@trailfx.com



1 866 638 4870



POLISHED STAINLESS STEEL – LIMITED LIFETIME
POWDER COATED BLACK – 3 YEARS

PARTS LIST:

Qty	Part Description	Qty	Part Description
1 Set	Side Bar	8	3/8"-16 Clip Nut Long
1 Set	Front Bracket	4	5/16"-18 x 1 1/2" Hex Head Bolt
1 Set	Rear Bracket	4	5/16" Lock Washer
16	3/8"-16 x 1 1/2" Hex Head Bolt	4	5/16" Flat Washer
16	3/8" Lock Washer	16	3/8" Flat Washer

DRIVER (LEFT) FRONT	DRIVER (LEFT) REAR	PASSENGER (RIGHT) REAR	PASSENGER (RIGHT) FRONT

INSTALLATION PROCEDURE

⚠ IMPORTANT: A magnetic pick up tool is recommended to assist with the installation.

1. Remove the end caps on the side bars before beginning installation.
2. First, install 3/8" clip nuts into the bottom of the inside rail of the rocker panel that line up with the side bar brackets. You will need to install 2 for each of the four brackets.
3. Place the holding mounting bracket onto the interior wall of the rocker panel. Place two 3/8" bolts with 3/8" lock washer and 3/8" flat washer through the bottom two holes of the mounting bracket into the 3/8" clip nuts. One of the top holes should line up with an existing threaded insert in the rocker panel. Use the 7/16" hex nut and 7/16" lock washer and 7/16" washer to secure.
4. Once you have placed the mounting bracket onto the rocker panel, mount the side bar to the brackets with four 3/8" bolts, lock washers and flat washers.
5. Repeat this procedure for the other side.
6. After all mounting points are in place and Side Bars are aligned, tighten all bolts accordingly. Recheck bolts periodically.

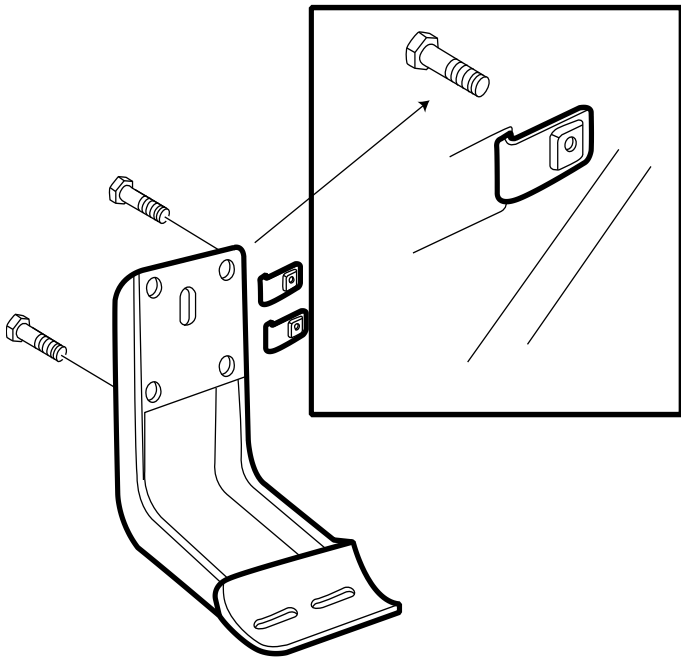
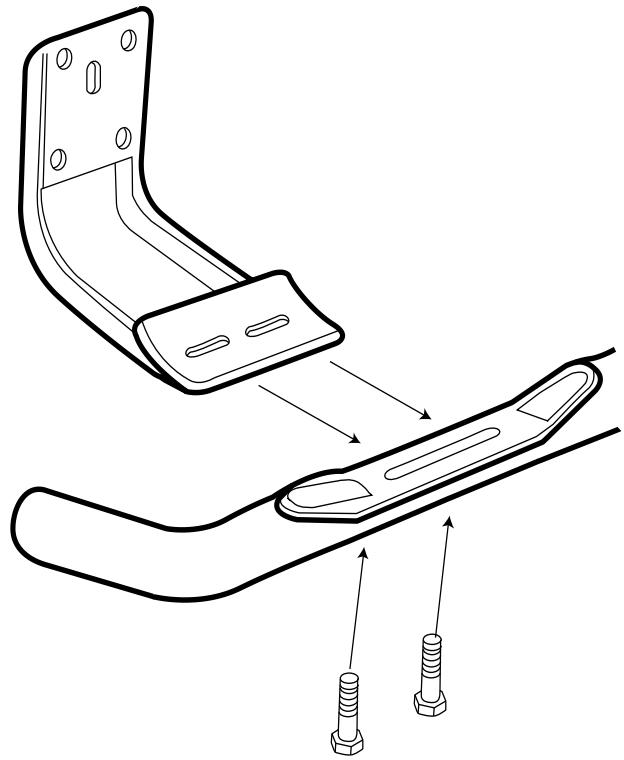

PARTS IDENTIFICATION GUIDE

Driver Side tube taped in "Red" Color. Passenger Side tube taped in "Blue" Color.

No.	Parts Identification
1	Passenger / Right 'Rear' Bracket marked "RR"
2	Driver / Left 'Rear' Bracket marked "RL"
3	Passenger / Right 'Center' Bracket marked "CR"
4	Driver / Left 'Center' Bracket marked "CL"
5	Passenger / Right 'Front' Bracket marked "FR"
6	Driver / Left 'Front' Bracket marked "FL"
7	'Left' marked "L"
8	'Right' marked "R"

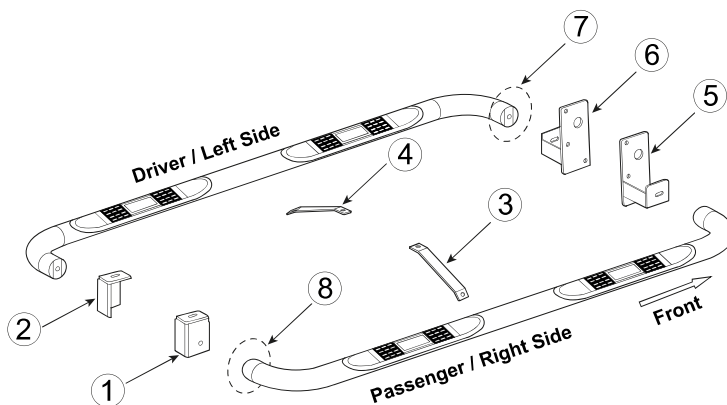

Note:

- This guide is to identify the parts and not a reference for part count.
- Product / Bracket image is for representative purpose only.
- Actual design may vary based on application.
- Refer Parts List for Hardware.

PRODUCT CARE

- Periodically check the product to ensure all fasteners are tight and components are intact.
- Regular waxing is recommended to protect the finish of the product.
- **Use ONLY Non-Abrasive automotive wax.** Use of any soap, polish or wax that contains an abrasive is detrimental and can scratch the finish leading to corrosion.
- Aluminum polish may be used to polish small scratches and scuffs for **Stainless Steel finish.**
- Mild soap may be used to clean the product for both **Stainless Steel and Black finish.**

FAQ's

- 1. Hardware's are not of correct size.**
In GMC / Chevrolet truck model 2006 & up, customer needs to reuse the factory body bolts to install the bracket. If your vehicle is not GMC / Chevrolet 2006 & up, ensure that holes are not partially covered with any plastic grommet or rust? If it is, remove the plastic grommet & rust from the thread holes & re-try the installation.
- 2. Mounting Bracket are not getting Installed properly.**
In some cases Illustration images shown in Installation manual may not be the exactly same as per actual vehicle images ,also if Driver / Passenger side mounting brackets are very identical in the design, suggest referring Parts Identification guide to avoid fitment issue.
- 3. Products are thumping / rattling after installation.**
Ensure that all required mounting brackets / hardware's are installed & tighten correctly. Suggest using white lithium / regular grease between the metal to metal contact surfaces.
- 4. Side Bar is not aligning with vehicle / Step Pads are not aligning with vehicle doors.**
Side bar may be interchanged or mounting brackets are not installed at the correct position in the vehicle. Refer Parts identification guide.
- 5. Missing / Excess Hardware.**
Recheck hardware count as per the part list.
- 6. Product not installing properly.**
Ensure make model year, cab length and bed size of your vehicle is listed in the application. All installation steps are followed correctly.

Check out these other TrailFX Products!!

www.TrailFX.com



Keystone Automotive Operations Inc. (KAO) warrants this product to be free of defects in material and workmanship at the time of purchase by the original retail consumer. KAO disclaims any other warranties, express or implied, including the warranty of fitness for a particular purpose or an intended use. If the product is found to be defective, KAO may replace or repair the product at our option, when the product is returned prepaid, with proof of purchase. Alteration to, improper installation, or misuse of this product voids the warranty. KAO's liability is limited to repair or replacement of products found to be defective, and specifically excludes liability for any incidental or consequential loss or damage.