

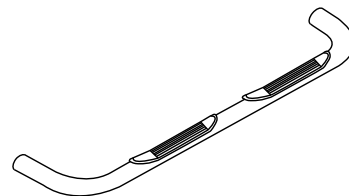

3" Side Bar

Part No. 1110180001/3



Fits: **2000 - 2013** **Chevrolet Avalanche 1500**
2000 - 2014 **Chevrolet Suburban 1500**
2000 - 2014 **GMC Yukon XL**

- CAN'T FIT WITH Z71 MODELS
- REMOVE CONTENTS FROM BOX. VERIFY ALL PARTS ARE PRESENT.
- READ INSTRUCTIONS CAREFULLY BEFORE STARTING INSTALLATION.
- DO NOT OVER TORQUE. STANDARD OPERATING LOAD FOR TIGHTEN BODY MOUNT NUTS & BOLTS VARIES FROM 45 TO 65 FOOT POUND.

- INSTALL TIME: 30-60 min
- Cutting Not Required
- Drilling Not Required
- support@trailfx.com
- 1 866 638 4870
- POLISHED STAINLESS STEEL – LIMITED LIFETIME
POWDER COATED BLACK – 3 YEARS

PARTS LIST:

Qty	Part Description	Qty	Part Description
1 Set	Side Bar	10	1/2" Lock Washer
1 Set	Front Bracket	2	3/8"-16 x 1" Hex Head Bolt
1 Set	Rear Bracket	2	3/8" Flat Washer
4	1/2"-13 x 2" Hex Head Bolt	2	3/8" Lock Washer
6	M12-1.75 x 120mm Hex Head Bolt	14	1.88"OD Spacer Washer
10	1/2" Flat Washer		

DRIVER (LEFT)FRONT	DRIVER (LEFT)CENTER	DRIVER (LEFT)REAR	PASSENGER (RIGHT)REAR	PASSENGER (RIGHT)CENTER	PASSENGER (RIGHT)FRONT

INSTALLATION PROCEDURE

⚠ IMPORTANT: A magnetic pick up tool is recommended to assist with the installation.

1. Remove the end caps on the side bars before beginning installation.
2. Locate the correct Side Bar and set of Brackets referenced in the illustration. (See Illustration1).
3. **Bracket Installation** Locate the existing bolts on the correct body mounts of the chassis. Remove them and install the brackets (See Illustration). Use the M12x1.75x120mm Hex Head Bolts with the 1/2" Flat and 1/2" Lock Washers. Do not tighten. (See Illustration). On the center bracket use (2) 1.88" spacer washers between the center bracket and the body mount.
4. **Side Bar Installation** Hold the side bar up to the front and rear brackets and install using the 1/2"-13 x 2" Hex Head Bolts with the 1/2" Flat and Lock Washers. (See Illustration). Attach the center bracket to the sidebar with the 3/8"-16x1" hex bolt, 3/8" lock washer and 3/8" flat washer.
5. Tighten the body mount bolts and auxiliary bracket. Then align the Side Bar and tighten the Side Bar bolts.
6. Recheck bolts periodically.

Driver's Side Installation Shown

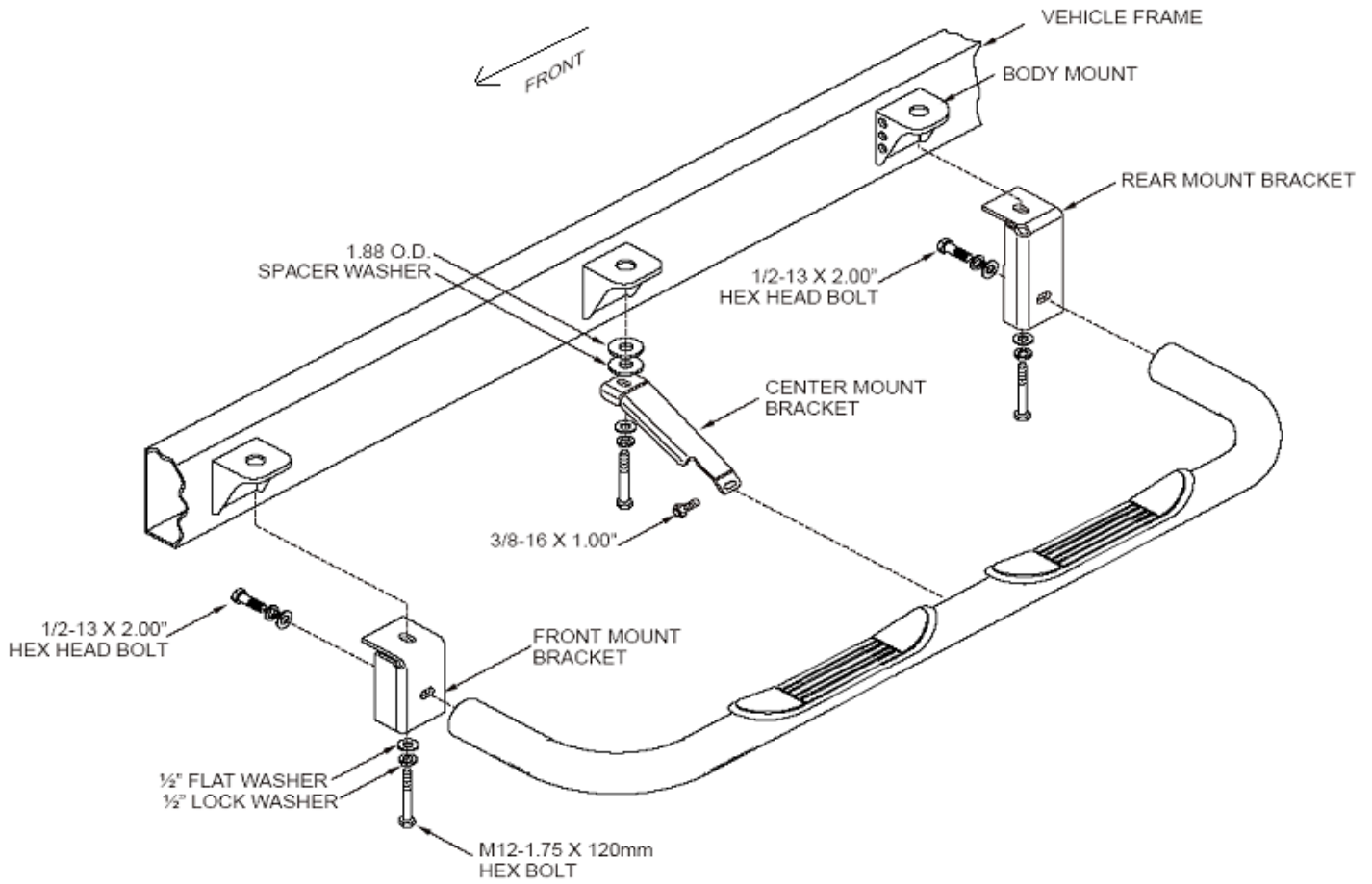

PARTS IDENTIFICATION GUIDE

Driver Side tube taped in "Red" Color. Passenger Side tube taped in "Blue" Color.

No.	Parts Identification
1	Passenger / Right 'Rear' Bracket marked "RR"
2	Driver / Left 'Rear' Bracket marked "RL"
3	Passenger / Right 'Center' Bracket marked "CR"
4	Driver / Left 'Center' Bracket marked "CL"
5	Passenger / Right 'Front' Bracket marked "FR"
6	Driver / Left 'Front' Bracket marked "FL"
7	'Left' marked "L"
8	'Right' marked "R"

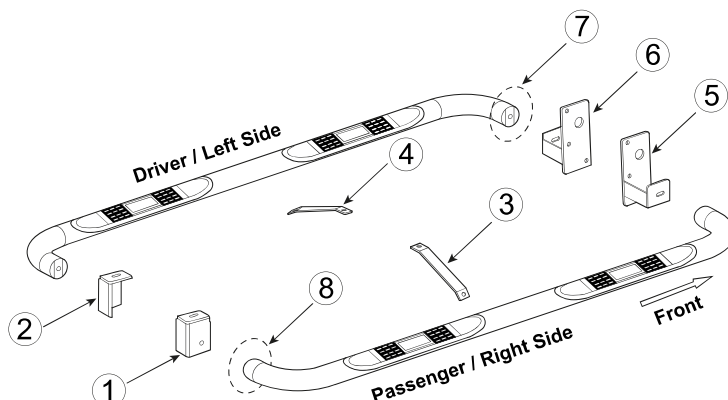

Note:

- This guide is to identify the parts and not a reference for part count.
- Product / Bracket image is for representative purpose only.
- Actual design may vary based on application.
- Refer Parts List for Hardware.

PRODUCT CARE

- Periodically check the product to ensure all fasteners are tight and components are intact.
- Regular waxing is recommended to protect the finish of the product.
- **Use ONLY Non-Abrasive automotive wax.** Use of any soap, polish or wax that contains an abrasive is detrimental and can scratch the finish leading to corrosion.
- Aluminum polish may be used to polish small scratches and scuffs for **Stainless Steel finish.**
- Mild soap may be used to clean the product for both **Stainless Steel and Black finish.**

FAQ's**1. Hardware's are not of correct size.**

In GMC / Chevrolet truck model 2006 & up, customer needs to reuse the factory body bolts to install the bracket. If your vehicle is not GMC / Chevrolet 2006 & up, ensure that holes are not partially covered with any plastic grommet or rust? If it is, remove the plastic grommet & rust from the thread holes & re-try the installation.

2. Mounting Bracket are not getting Installed properly.

In some cases Illustration images shown in Installation manual may not be the exactly same as per actual vehicle images ,also if Driver / Passenger side mounting brackets are very identical in the design, suggest referring Parts Identification guide to avoid fitment issue.

3. Products are thumping / rattling after installation.

Ensure that all required mounting brackets / hardware's are installed & tighten correctly. Suggest using white lithium / regular grease between the metal to metal contact surfaces.

4. Side Bar is not aligning with vehicle / Step Pads are not aligning with vehicle doors.

Side bar may be interchanged or mounting brackets are not installed at the correct position in the vehicle. Refer Parts identification guide.

5. Missing / Excess Hardware.

Recheck hardware count as per the part list.

6. Product not installing properly.

Ensure make model year, cab length and bed size of your vehicle is listed in the application. All installation steps are followed correctly.

Check out these other TrailFX Products!!

www.TrailFX.com



BULL BARS



GRILLE GUARDS



BED RAILS



RUNNING BOARDS

Keystone Automotive Operations Inc. (KAO) warrants this product to be free of defects in material and workmanship at the time of purchase by the original retail consumer. KAO disclaims any other warranties, express or implied, including the warranty of fitness for a particular purpose or an intended use. If the product is found to be defective, KAO may replace or repair the product at our option, when the product is returned prepaid, with proof of purchase. Alteration to, improper installation, or misuse of this product voids the warranty. KAO's liability is limited to repair or replacement of products found to be defective, and specifically excludes liability for any incidental or consequential loss or damage.