

ABSJRC01

Rear suspension package Ensemble pour suspension arrière Ensemble para suspensión de trasero

INSTALLATION INSTRUCTIONS

- Raise vehicle allowing the axle to hang freely.
- Remove existing bump stop assembly.
- Assemble Aeon rubber spring and bracket as shown in the adjacent diagram.
- Mount Timbren assembly using existing holes & Timbren supplied fasteners.
- Lower vehicle.

Notes:

If vehicle has box frame, use OEM fasteners.
When removing OEM fasteners, use penetrating fluid.

Do not exceed vehicle manufacturer's recommended axle weight rating. Check for AEON® interference with vehicle components - Under load AEON® will "expand" in diameter.

INSTRUCTIONS DE MONTAGE

- Soulever le véhicule de sorte que l'essieu soit dégagé.
- Retirer l'assemblage de la butée de suspension existante.
- Assembler le ressort en caoutchouc Aeon et le support comme il est indiqué dans le schéma adjacent.
- Monter l'assemblage Timbren en utilisant les trous existants et la boulonnerie fournie avec l'assemblage Timbren.
- Redescendre le véhicule.

Remarques:

Réutiliser la boulonnerie d'origine si le véhicule a un cadre tubulaire.
Utiliser un fluide pénétrant, au moment de retirer la boulonnerie du fabricant d'équipement.

Ne pas dépasser le poids nominal sur l'essieu recommandé par le fabricant du véhicule. Vérifier que le ressort AEON® n'a pas d'incidence sur d'autres pièces du véhicule - Le ressort AEON® augmentera son diamètre avec la charge.

INSTRUCCIONES DE INSTALACIÓN

- Levante el vehículo dejando que los ejes cuelguen libremente.
- Retire la unidad del tope de suspensión existente.
- Ensamble el resorte de caucho Aeon y la abrazadera como se muestra en el diagrama adyacente.
- Monte la unidad Timbren utilizando los orificios existentes y los elementos de sujeción Timbren provistos.
- Baje el vehículo.

Notas:

Reutilizar los pernos y tuercas del fabricante original si el chasis del camion esta tubular.
Al remover los elementos de sujeción del fabricante original del equipo, utilice fluido penetrante.

No exceda la carga nominal en el eje recomendada por el fabricante del vehículo. Compruebe que no haya interferencia entre el resorte AEON® y los otros componentes del vehículo. Bajo carga, el resorte AEON® se ampliará en diámetro.

Ref. = Reference = No. de référence = Núm. de referencia
Part = Part #. = No. de pièce = Núm. de pieza
Qty. = Quantity = Quantité = Cantidad

Ref	Part	Qty
1	F11063-150	4
2	K10048-003	2
3	F40031-020	4
4	F31003-150	4
5	A1602BA-003	2
6	A00515-55F60	2
7	F11102-150	2

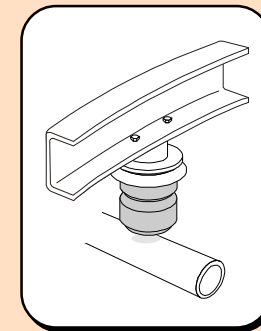
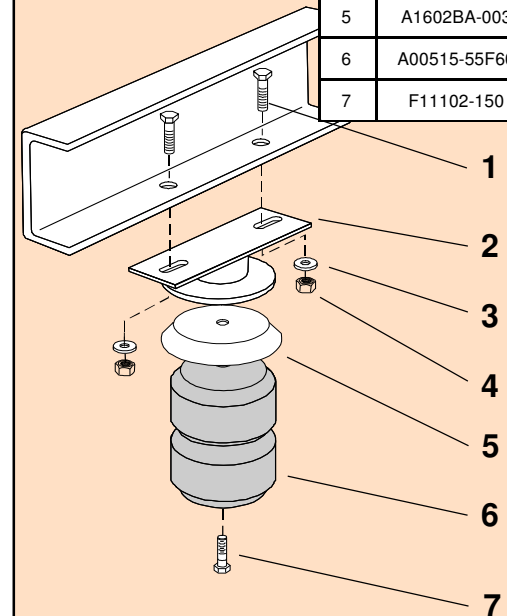

ABSJRC01



ABSJRC01

TIMBREN INDUSTRIES INC.

www.timbren.com

PART NUMBER	DESCRIPTION	QTY	LOCATION
F31003-150	NYLOCK LOCKNUT 3/8 UNF GR 5 Z	4	G1C
F40031-020	WASHER FLAT USS 3/8 x 1 GR 2 Z	4	G1C
F11063-150	HCS 3/8 x 1-1/2 UNF GR 5 Z	4	G1C
F11102-150	HCS 1/2 x 1-1/2 UNF GR 5 Z	2	G1D
A00515-55F60	Hollow Rubber Spring	2	C5B
K10048-003	JRC01 WELDMENT PAINTED	2	E1A
A1602BA-003	STEEL CUP 3-7/8 od x 13/32 id x 1/2" dp. PTD	2	D21A
B90215	Carton 8.5 x 6.5 x 5	1	A5A
B10000	8" x 12" BUBBLE FOR KITS	1	
B00029-010	BARCODE LABEL FOR KIT	1	
B90121-010	OFFROAD KIT BOX LABEL	1	

ASSEMBLY NOTES:

Issued: 12/17/2015

Lifetime Warranty:

Timbren SES Kits are warranted against defects in material and workmanship, under normal use and service, for the life of the vehicle on which the kit was originally installed. The warranty is not transferable and proof of purchase is required. The warranty is limited to the replacement of the failed part.

TIMBREN will not be responsible for any labour or freight charges involved in the replacement of any product. TIMBREN shall be entitled to make its own inspection to determine the validity of the claim. TIMBREN shall not be liable nor warranty the product in the event of alteration, misuse, overload, negligence or damage caused by others.

If ride or performance of our product is unsatisfactory in any way, please call: 1-800-263-3113 or email sales@timbren.com