

**ELEVATION BULL NOSE FRONT BUMPER
2005-15 TOYOTA TACOMA**

PARTS LIST:

1	Front Bumper	2	10mm Double Bolt Plates
1	Bull Nose Hoop	4	10-1.5mm x 25mm Hex Bolts
1	Winch Tray	8	10mm x 30mm x 2.5mm Flat Washers
1	Driver/left Frame Mounting Bracket	4	10mm Lock Washers
1	Passenger/right Frame Mounting Bracket	4	10mm Nylon Lock Nuts
1	Driver/left Lower Support Bracket	2	8-1.25mm x 16mm Hex Bolts
1	Passenger/right Lower Support Bracket	2	8-1.25mm x 25mm Hex Bolts
1	Winch Access Cover	6	8mm x 24mm x 2mm Flat Washers
2	Plastic Plugs for License Plate	4	8mm Lock Washer
1	"L" Light bracket driver side	2	8mm Hex Nut
1	"L" Light bracket passenger side	5	6mm Combo Bolts (access cover)
2	12-1.75mm x 120mm Hex Bolts	1	4mm Wrench
12	12-1.75mm x 40mm Hex Bolts	8	6mm x 20mm Hex Bolts
28	12mm x 32mm OD x 3mm Flat Washers	16	6mm x 12mm x 1.6mm Flat Washers
14	12mm Nylon Lock Nuts	8	6mm Nylon Lock Nuts

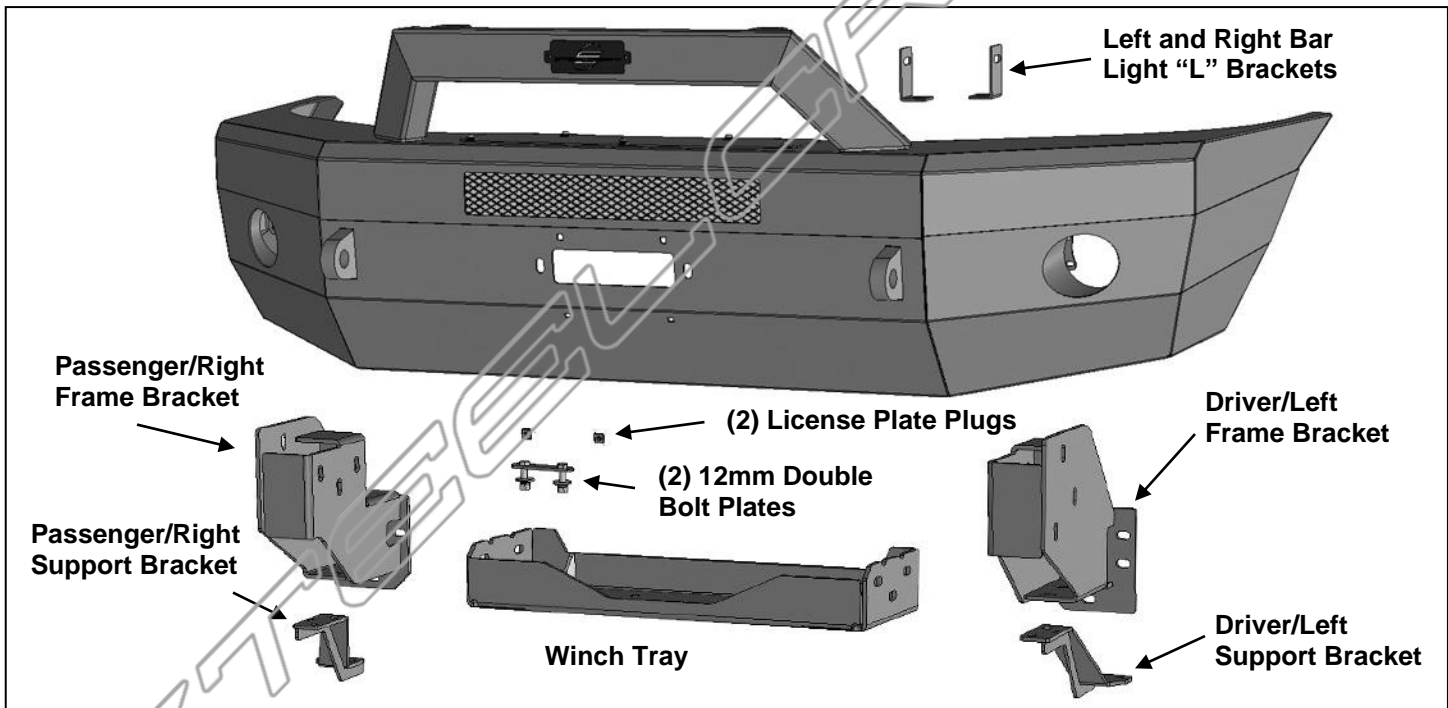

PROCEDURE:

REMOVE CONTENTS FROM BOX. VERIFY ALL PARTS ARE PRESENT. READ INSTRUCTIONS CAREFULLY BEFORE STARTING INSTALLATION. BUMPER IS HEAVY, ASSISTANCE IS HIGHLY RECOMMENDED TO AVOID POSSIBLE INJURY OR DAMAGE TO THE VEHICLE.

1. Remove the license plate and bracket from the bumper cover.
2. Move to the driver/left wheel opening. Remove the hardware attaching the plastic bumper cover to the bottom of the front fender and inner fender liner. On models with factory fog lights, unplug both lights and release the wiring harnesses from the clips attached to the back of the bumper and move wiring harnesses away from the bumper. Repeat this Step to release the passenger side of the cover.
3. Remove the clips from the bottom and the top of the bumper cover and remove the bumper cover, **(Figure 1)**. **NOTE:** Depending on model year, it may be necessary to temporarily remove the grille and plastic fill panels below the head lights to access cover hardware.
4. Remove the aluminum inner bumper assembly from the ends of the frame, **(Figure 2)**.
5. Next, remove the tow hook if equipped. **NOTE:** Tow hook will not be reinstalled. Also remove the short frame extensions from both ends of the crossmember, **(Figure 2)**.

**ELEVATION BULL NOSE FRONT BUMPER
2005-15 TOYOTA TACOMA**

6. Select the driver/left Frame Bracket, **(Figure 3)**. Reuse the (3) factory hex nuts to attach the Bracket to the frame, **(Figures 3 & 4)**.
7. Insert (1) 12mm x 120mm Hex Bolt with (1) 12mm Flat Washer through the lower mounting hole in the bracket and through the end of the frame channel. Use the included (1) 12mm Flat Washer and (1) 12mm Nylon Lock Nut to secure the Bracket to the lower mounting hole, **(Figure 5)**. Snug but do not fully tighten hardware at this time.
8. Next, select the driver/left Support Bracket, **(Figure 6)**. Reuse the factory hex bolt to attach the inner end of the Support Bracket to the bottom of the cross member. Select (1) 10mm Double Bolt Plate. Insert the Bolt Plate into the end of the Frame Bracket and down through the (2) holes in the bottom and through the Support Bracket. Attach the Support Bracket to the Double Bolt Plate with (2) 10mm Flat Washers and (2) 10mm Nylon Lock Nuts, **(Figures 6 & 7)**. Snug but do not fully tighten hardware at this time.
9. Repeat **Steps 6—8** to install the passenger/right Frame Bracket and Support Bracket.
10. **Optional Winch Tray and Winch installation (winch sold separately):**
 - a. Select the Winch Tray. With assistance, slide the Winch Tray between the Frame Brackets. Attach the Winch Tray to the Frame Brackets with (6) 12mm x 40mm Hex Bolts, (12) 12mm Flat Washers and (6) 12mm Nylon Lock Nuts, **(Figures 8 & 9)**. Snug but do not fully tighten all hardware.
IMPORTANT: LED bar style light cannot be installed with Winch Tray. If installation of LED bar style light is desired, do not install the Winch Tray and skip to Step 11.
 - b. If installing winch, follow manufacturer's instructions to attach the winch to the Winch Tray. Winch must be installed before Bumper is placed in position against Brackets. Attach winch cable guide, (not included), to Bumper assembly. Follow manufacturer's instructions to properly wire the winch to the electrical system.
11. **Optional Center LED light installation (sold separately). NOTE:** Light must be installed before Bumper Assembly is attached to the Frame Brackets. **IMPORTANT: Winch Tray cannot be installed with LED bar style light assembly.**
 - a. Select the L/R "L" Brackets, **(Figure 10)**. **NOTE:** "L" Brackets are offset for universal fitment for most LED bar style lights. Attach the LED light assembly to the "L" Brackets with the included (2) 8mm x 16mm Hex Bolts, (2) 8mm Lock Washers and (2) 8mm Flat Washers. Do not fully tighten hardware at this time. **NOTE:** "L" Brackets may require modification for hardware larger than 8mm or use brackets supplied with light if possible.
 - b. Attach the light and Brackets to the top of the (2) tabs on the back of the Bumper with the included 8mm x 25mm Hex Bolts, (4) 8mm Flat Washers, (2) 8mm Lock Washers and (2) 8mm Hex Nuts, **(Figure 10)**. Adjust light position and tighten hardware.
 - c. Follow light manufacturer's instructions to wire the light once Bumper has been fully installed.
12. **Optional "Bull Nose" bolt on Hoop.** Bull Nose Hoop must be installed before installing Bumper. Attach Bull Nose Hoop to top of Bumper with (4) 10mm Hex Bolts, (4) 10mm Lock Washers and (4) 10mm Flat Washers, **(Figure 11)**. Fully tighten 10mm hardware at this time only.
13. With assistance, position the Bumper Assembly up to the outside of the Frame Brackets. Temporarily support the weight of the Bumper. **WARNING:** To avoid possible injury or damage to the vehicle, do not proceed until the Bumper is fully and safely supported.
14. Line up the driver/left side mounting plate on the back of the Bumper with the (3) slots in the Frame Bracket. Attach the Bumper to the Bracket with the included (3) 12mm x 40mm Hex Bolts, (6) 12mm Flat Washers and (3) 12mm Nylon Lock Nuts, **(Figures 12 & 13)**. Do not fully tighten hardware at this time. Repeat this Step to attach the passenger/right side of Bumper.
15. Level and adjust the bumper and fully tighten all 12mm hardware to 65-70ft-lbs. Remove access cover on the top of the Bumper to reach hardware if necessary. **NOTE:** It may be necessary to temporarily remove the outer bumper assembly to shift the inner Winch Tray/Bracket assembly left or right for more adjustment. Once properly adjusted, fully tighten the Winch Tray to Frame Bracket hardware first, then Frame Bracket to frame, Support Bracket to Frame Bracket then reinstall the outer Bumper assembly and fully tighten the Bumper mounting hardware.
16. **Models with factory fog lights:**
 - a. Remove the driver/left light assembly from the back of the bumper.

**ELEVATION BULL NOSE FRONT BUMPER
2005-15 TOYOTA TACOMA**

- b. Attach the light assembly to the tabs on the back of the Bumper with (4) 6mm x 20mm Hex Bolts, (8) 6mm Flat Washers and (4) 6mm Nylon Lock Nuts. **IMPORTANT:** to avoid damage to the plastic tabs on the fog light, do not overtighten the hex bolts, **(Figure 14)**. **NOTE:** Mounting tabs may shift during shipping, adjust location of mounting tabs to line up properly with light assembly.
 - c. Repeat to install the passenger/right fog light.
 - d. Reattach the wiring harness. Adjust lights as necessary and tighten all fog light bracket hardware.
17. Use the included (2) push-in plastic nuts to attach the front license plate, (if required), to the (2) holes in the front bumper, **(Figure 15)**.
18. Do periodic inspections to the installation to make sure that all hardware is secure and tight.

To protect your investment, wax this product after installing. Regular waxing is recommended to add a protective layer over the finish. Do not use any type of polish or wax that may contain abrasives that could damage the finish. Mild soap may be used to clean the Front Bumper assembly.

Driver/left Side Installation Pictured

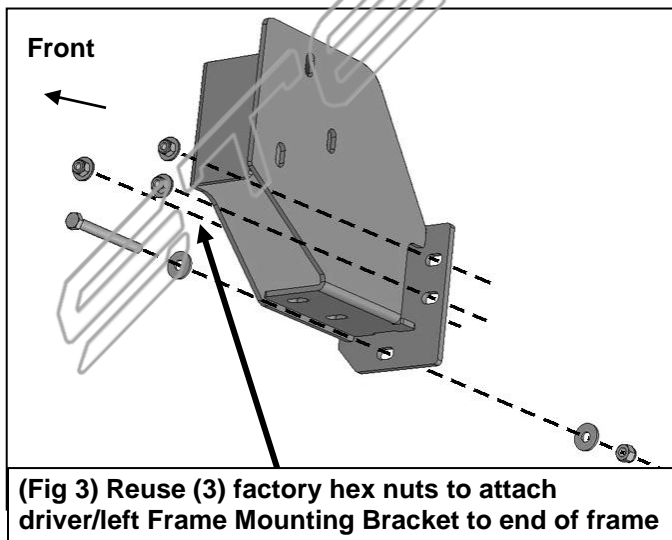
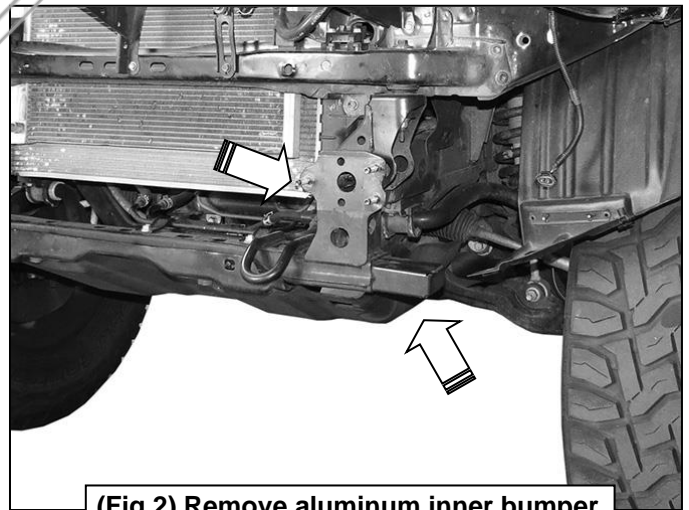
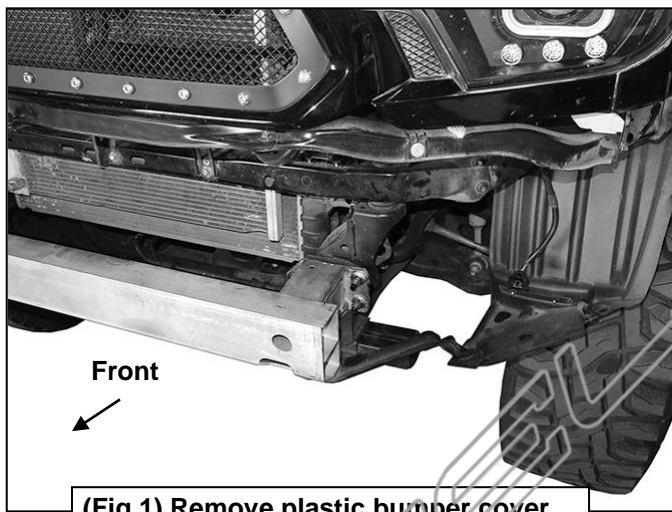

Driver/left Side Installation Pictured

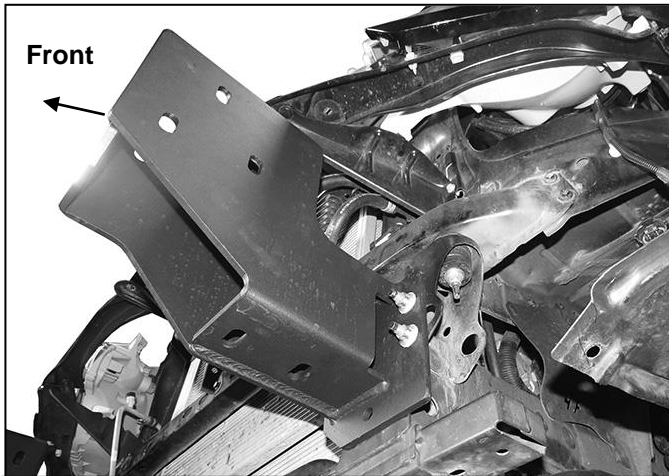

(Fig 4) Driver/left Frame Bracket attached to frame

12mm x 120mm Hex Bolt
12mm Flat Washer

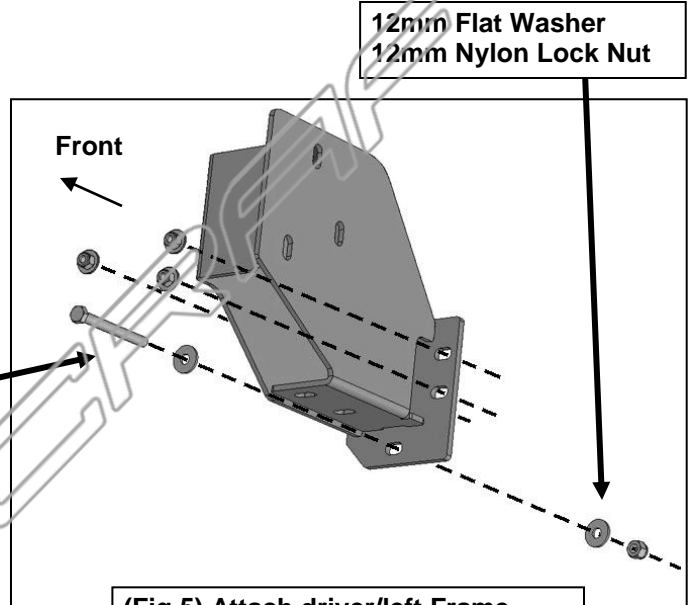

(Fig 5) Attach driver/left Frame
Mounting Bracket to crossmember

Reuse factory hex bolt to attach
driver/left Support Bracket to
bottom of crossmember

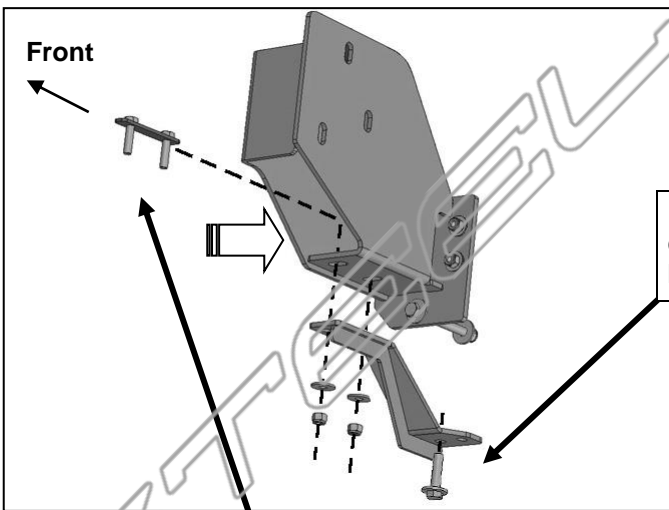

(Fig 6) Insert Double Bolt Plate into Frame
Bracket and down through Support Bracket

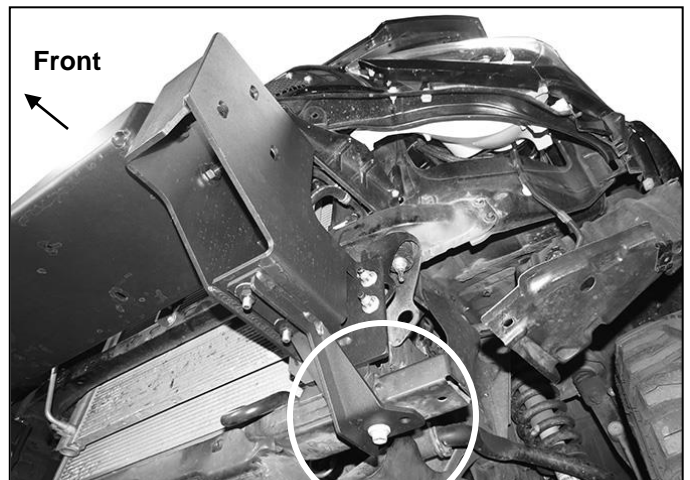

(Fig 7) Reuse factory hex bolt to attach driver/left
Support Bracket to bottom of crossmember

ELEVATION BULL NOSE FRONT BUMPER
2005-15 TOYOTA TACOMA

Driver/left Side Installation Pictured

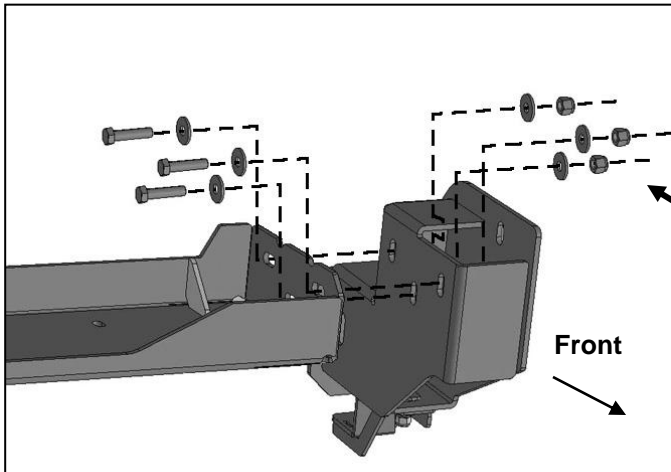

- (3) 12mm x 40mm Hex Bolts
- (6) 12mm Flat Washers
- (3) 12mm Nylon Lock Nuts

(Fig 8) Attach Winch Tray to inside of Frame Brackets

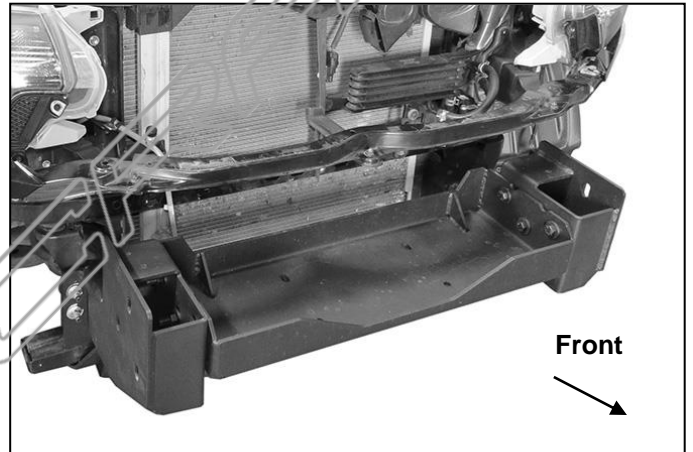

(Fig 9) Attach Winch Tray to inside of Frame Brackets

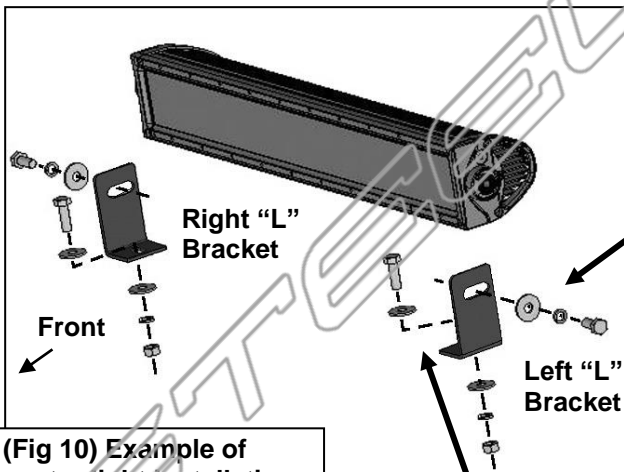

- (2) 8mm x 16mm Hex Bolts
- (2) 8mm Lock Washers
- (2) 8mm Flat Washers

(Fig 10) Example of center light installation

- (2) 8mm x 25mm Hex Bolts
- (4) 8mm Flat Washers
- (2) 8mm Lock Washers
- (2) 8mm Hex Nuts

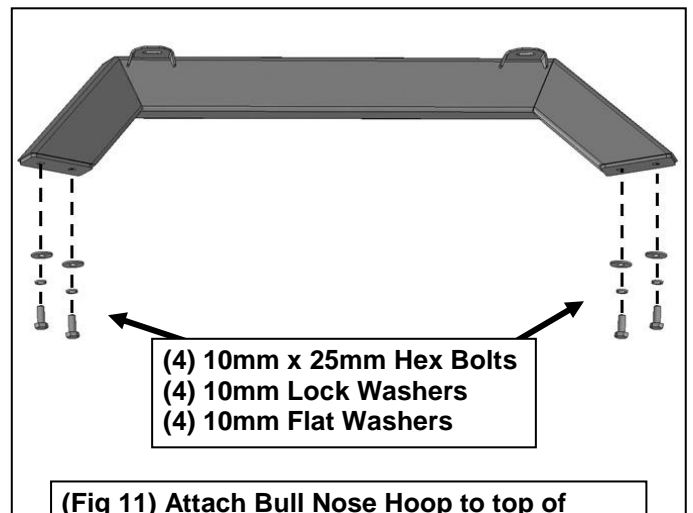

(Fig 11) Attach Bull Nose Hoop to top of Bumper assembly before installing Bumper

WARNING! Do not crawl under bumper unless the bumper is properly supported on blocks or stands or the bumper may fall.

ELEVATION BULL NOSE FRONT BUMPER
2005-15 TOYOTA TACOMA

Driver/left Side Installation Pictured

