

**ELEVATION BULL NOSE FRONT BUMPER  
2010-17 DODGE RAM 2500-3500**

**PARTS LIST:**

1	Elevation Bull Nose Front Bumper Assembly	20	12mm Lock Washers
1	Driver/left Frame Mounting Bracket	20	12mm Hex Nuts
1	Passenger/right Frame Mounting Bracket	2	8-1.25mm x 25mm Hex Bolts
1	Driver/left LED Light Bracket	2	8-1.25mm x 16mm Hex Bolts
1	Passenger/right LED Light Bracket	6	8mm x 24mm x 2mm Flat Washers
1	Winch Tray	4	8mm Lock Washers
1	Winch Access Cover	2	8mm Hex Nuts
2	License Plate Mounting Plugs	5	6mm Combo Button Head Bolts
6	Rubber Sensor Plugs	1	4mm Wrench
8	12-1.75mm x 100mm Hex Bolts	12	4mm x 10mm Button Head Screws
12	12-1.75mm x 50mm	1	2.5mm Wrench
40	12mm x 37mm OD x 3mm Flat Washers		

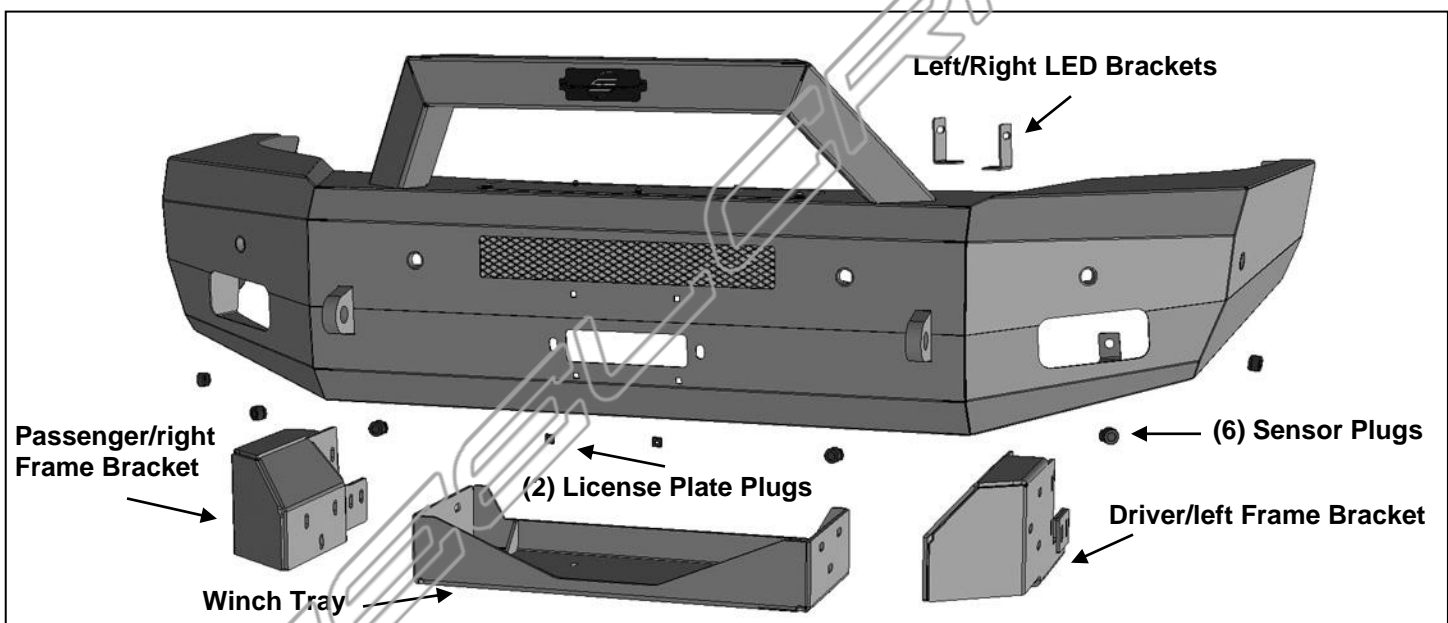

**PROCEDURE:**

1. REMOVE CONTENTS FROM BOX. VERIFY ALL PARTS ARE PRESENT. READ INSTRUCTIONS CAREFULLY BEFORE STARTING INSTALLATION. BUMPER IS HEAVY, ASSISTANCE IS HIGHLY RECOMMENDED. CUTTING MAY BE REQUIRED.
2. Open the front hood and temporarily remove the top plastic cover between the radiator and the grille. Next, remove the plastic radiator grille for easier access to top bumper bracket bolts, **(Figure 1)**. **NOTE:** Pay close attention to the type and location of all factory hardware for reinstallation. Move the grille and cover to a clean, stable work area.
3. **Models with factory fog lights and/or sensors:** Unplug the wiring harness from the back of the bumper, **(Figure 2)**. Move the wiring harness out of the way.
4. Locate the factory bumper bolts attaching the outer bumper to the inner brackets, **(Figure 3 & 4)**. With assistance, remove the bumper assembly, **(Figure 5)**. Next, remove the (2) tow hooks.
5. Remove the driver side inner bumper bracket and lower frame extension from the ends of the frame, **(Figures 5—7)**. **NOTE:** Lower frame extensions cannot be reinstalled.
  - a. **IMPORTANT:** On models equipped with a diesel engine, the intercooler will need to be moved out of the way to remove the bumper bracket. Assistance is highly recommended to avoid damaging the intercooler.
  - b. Remove the hex bolts attaching the hanging brackets to the inside of the frame, **(Figure 6)**. Loosen the hex bolts attaching the brackets to the intercooler. Remove the double bolt plates

**ELEVATION BULL NOSE FRONT BUMPER  
2010-17 DODGE RAM 2500-3500**

and bumper brackets, **(Figure 7)**. If the intercooler cannot be moved enough to clear the double bolt plates, loosen the intercooler hoses. If the double bolt plates still cannot be removed, it will be necessary to temporarily remove the intercooler. **WARNING:** Be very careful to avoid damaging the intercooler.

6. Reinstall the grille and top cover.
7. Select the driver/left Frame Mounting Bracket, **(Figure 8)**. Line up the holes in the Bracket with the holes through the frame for the bumper bracket. Attach the Mounting Bracket to the frame with (4) 12mm x 100mm Hex Bolts, (8) 12mm Flat Washers, (4) 12mm Lock Washers and (4) 12mm Hex Nuts, **(Figures 8 & 9)**. Snug but do not fully tighten hardware at this time. Repeat this Step to install the passenger side Mounting Bracket, **(Figure 10)**.
  - a. On models equipped with diesel engine, reinstall the intercooler and mounting brackets at this time. Fully tighten intercooler bracket hardware only, **(Figure 7)**.
8. Select the Winch Tray assembly. Line up the Winch Tray between the Mounting Brackets. Attach the Winch Tray to the Mounting Brackets with (6) 12mm x 50mm Hex Bolts, (12) 12mm Flat Washers, (6) 12mm Lock Washers and (6) 12mm Hex Nuts, **(Figures 11 & 12)**. Snug but do not fully tighten hardware at this time.
9. If installing winch, attach winch to Winch Tray at this time. Winch must be installed before Bumper is placed in position against Brackets. Install winch cable guide on Bumper assembly. Follow manufacturer's instructions to properly wire the winch to the electrical system.
10. **Optional Center LED light installation** (sold separately). **NOTE:** Light must be installed before Bumper Assembly is attached to the Winch Tray. **IMPORTANT:** Clearance between the bar style LED light and the winch and/or winch tray must be determined before installing Bumper assembly.
  - a. Select the L/R "L" Brackets, **(Figure 13)**. **NOTE:** "L" Brackets are offset for universal fitment for most LED bar style lights. Attach the LED light assembly to the "L" Brackets with the included (2) 8mm x 16mm Hex Bolts, (2) 8mm Lock Washers and (2) 8mm Flat Washers, **(Figure 13)**. Do not fully tighten hardware at this time. **NOTE:** "L" Brackets may require modification for hardware larger than 8mm or use brackets supplied with light if possible.
  - b. Attach the light and brackets to the top of the (2) tabs on the back of the Bumper with the included 8mm x 25mm Hex Bolts, (4) 8mm Flat Washers, (2) 8mm Lock Washers and (2) 8mm Hex Nuts, **(Figure 13)**. Adjust light position and tighten hardware.
  - c. Follow light manufacturer's instructions to wire the light once Bumper has been fully installed.
11. Install sensors, (if equipped), before installing the Bumper.

**Models without bumper sensors:**

  - a. Select the included (6) Rubber Plugs.
  - b. From behind bumper, push plugs into sensor mounting holes, **(Figure 14)**.

**Models with bumper mounted sensors:**

  - a. Push the sensor into the mounting socket in the back of the bumper.
  - b. Secure each sensor to the socket with (2) 4mm x 10mm Button Head Screws, **(Figure 14)**.

**IMPORTANT:** Sensors fit snug in sockets. The 4mm Screws are used to apply slight pressure to lock the sensors in place. Tighten both screws evenly until they touch the sensor body only. Do not overtighten screws or damage to sensors will result.
12. With assistance, carefully position the Bumper Assembly up to the Brackets. Temporarily support the weight of the Bumper. **WARNING:** To avoid possible injury or damage to the vehicle, do not proceed until the bumper is fully and safely supported.
13. Line up the (3) holes in the driver/left side of the Bumper with the (3) holes in the Frame Bracket. Attach the Bumper to the Bracket with the included (3) 12mm x 50mm Hex Bolts, (6) 12mm Flat Washers, (3) 12mm Lock Washers and (3) 12mm Hex Nuts, **(Figures 15 & 16)**. Do not fully tighten hardware at this time. Repeat to attach the passenger/right side of the Bumper to the Bracket.
14. Level and adjust the bumper and fully tighten all 12mm hardware to 65-70ft-lbs.
15. Use the included (2) push-in plastic nuts to attach the front license plate, (if required), to the (2) holes in the front bumper, **(Figure 17)**.
16. **Models with factory fog lights:**
  - a. Carefully remove the driver/left light assembly from the bracket on the back of the bumper, **(Figure 2)**.

**ELEVATION BULL NOSE FRONT BUMPER  
2010-17 DODGE RAM 2500-3500**

- b. Pop the light into the mounting tabs on the back of the Elevation bumper, **(Figure 18)**. **NOTE:** Tabs may move during shipping. Bend tabs as necessary to properly line up with bulb assembly.
  - c. Repeat to install the passenger/right fog light.
- 17.** Reattach the factory wiring harness to the sensors and fog lights. Adjust lights as necessary and tighten all hardware.
- 18.** Do periodic inspections to the installation to make sure that all hardware is secure and tight.

**To protect your investment**, wax this product after installing. Regular waxing is recommended to add a protective layer over the finish. Do not use any type of polish or wax that may contain abrasives that could damage the finish. Mild soap may be used to clean the Bumper Assembly.

**Driver Side Installation Pictured**

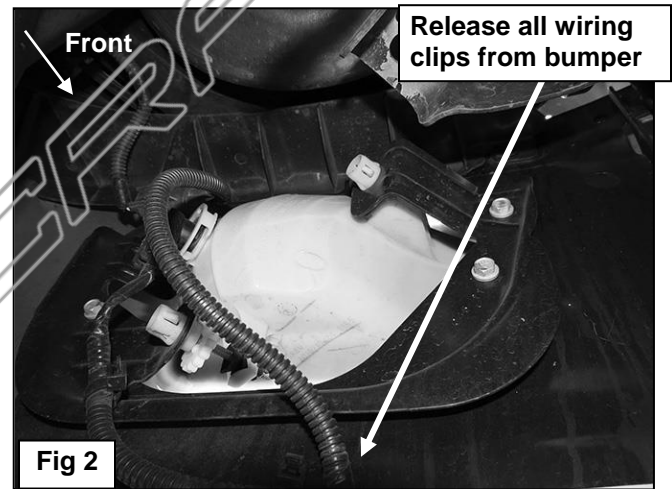
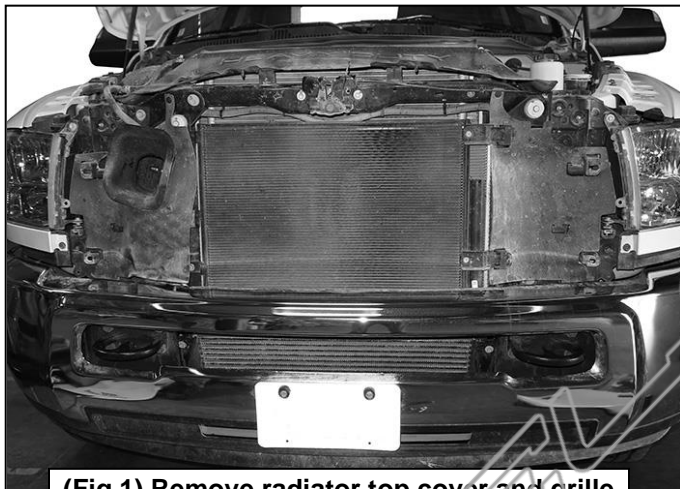

Remove lower frame extension  
(pictured from below)

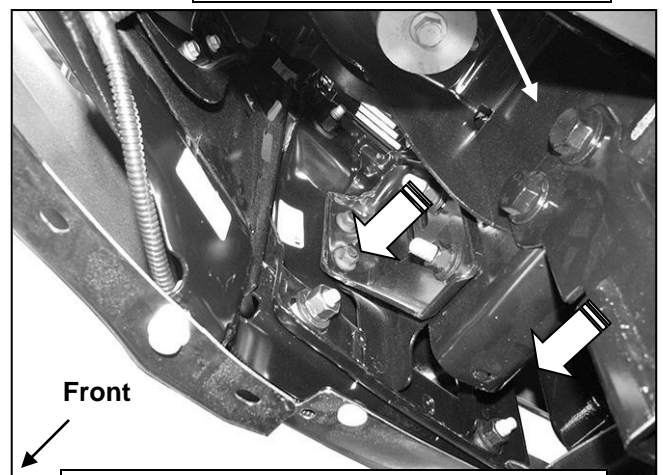

**ELEVATION BULL NOSE FRONT BUMPER  
2010-17 DODGE RAM 2500-3500**

**Driver Side Installation Pictured**

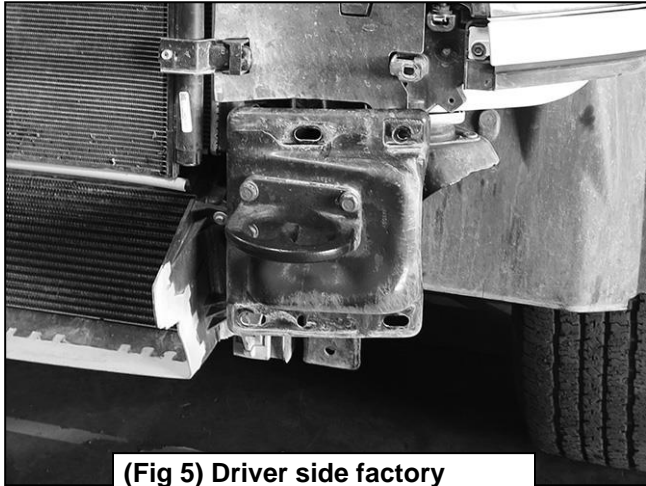

**(Fig 5) Driver side factory bumper bracket and tow hook**

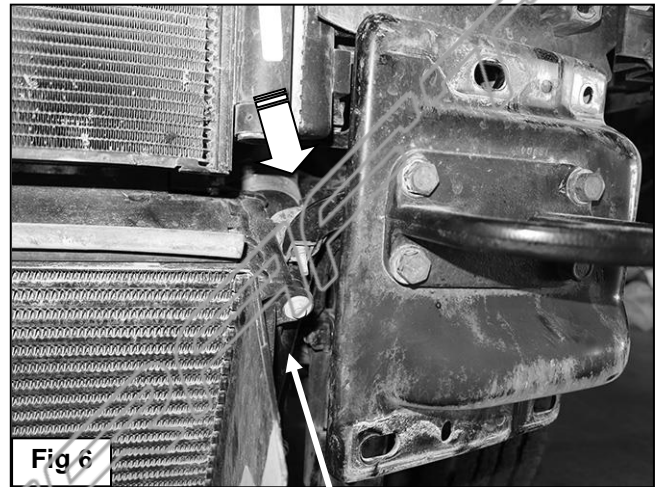

**Fig 6**

**Diesel models, loosen top support bracket hardware at frame and intercooler (large arrow). Temporarily remove lower hanging intercooler bracket from side of frame**

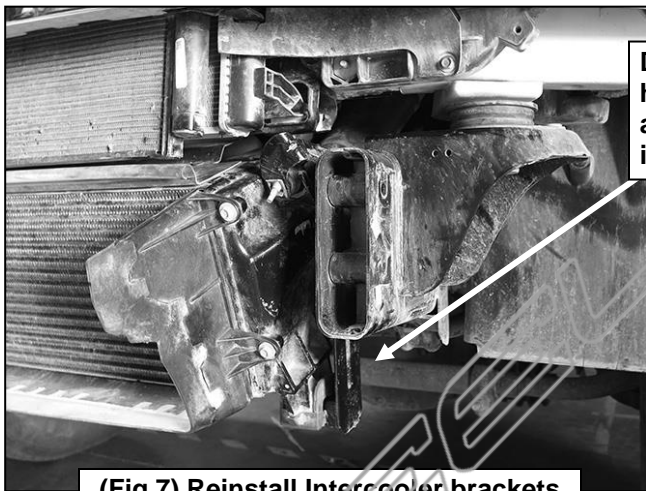

**(Fig 7) Reinstall Intercooler brackets**

- (4) 12mm x 100mm Hex Bolts**
- (8) 12mm Flat Washers**
- (4) 12mm Lock Washers**
- (4) 12mm Hex Nuts**

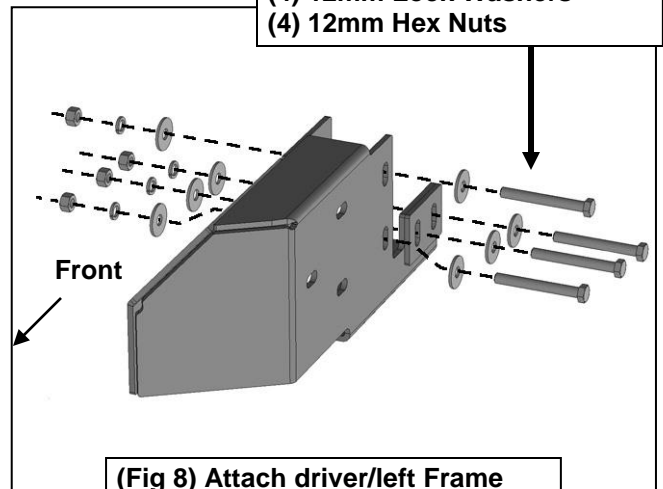

**(Fig 8) Attach driver/left Frame Mounting Bracket to end of frame**

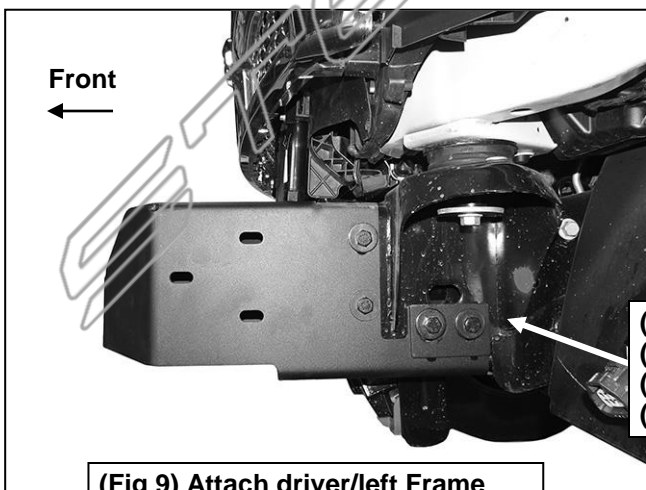

**(Fig 9) Attach driver/left Frame Mounting Bracket to end of frame**

- (4) 12mm x 100mm Hex Bolts**
- (8) 12mm Flat Washers**
- (4) 12mm Lock Washers**
- (4) 12mm Hex Nuts**

**ELEVATION BULL NOSE FRONT BUMPER  
2010-17 DODGE RAM 2500-3500**

**Driver Side Installation Pictured**

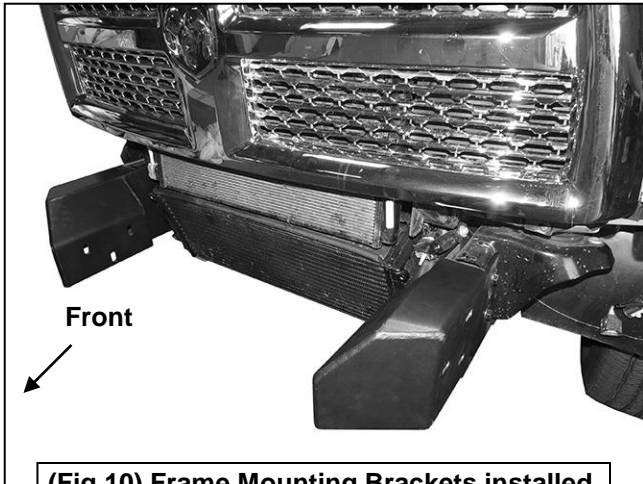

**(Fig 10) Frame Mounting Brackets installed**



**(Fig 12) Attach Winch Tray to Frame Brackets**

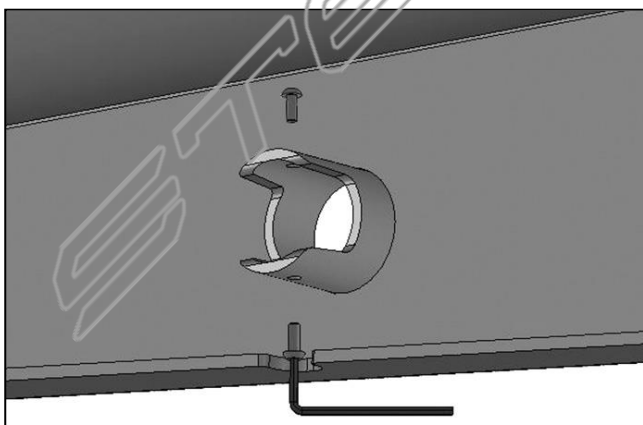

**(Fig 14) Push sensor into mounting sleeve. Use 4mm Screws to lock sensor in place.**

- (3) 12mm x 50mm Hex Bolts
- (6) 12mm Flat Washers
- (3) 12mm Lock Washers
- (3) 12mm Hex Nuts

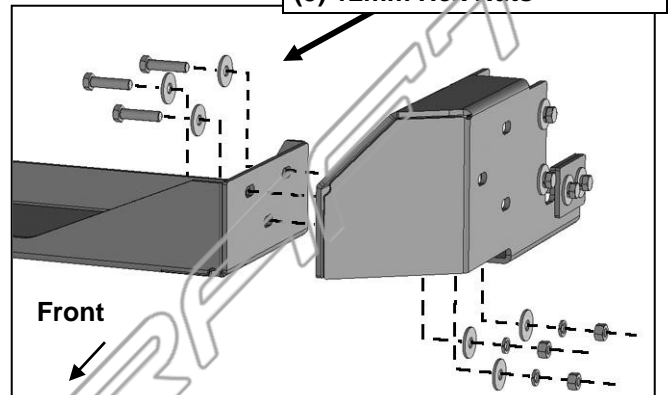

**(Fig 11) Attach Winch Tray to Frame Brackets**

- 8mm x 16mm Hex Bolt
- 8mm Lock Washer
- 8mm Flat Washer

- 8mm x 25mm Hex Bolt
- (2) 8mm Flat Washers
- 8mm Lock Washer
- 8mm Hex Nut

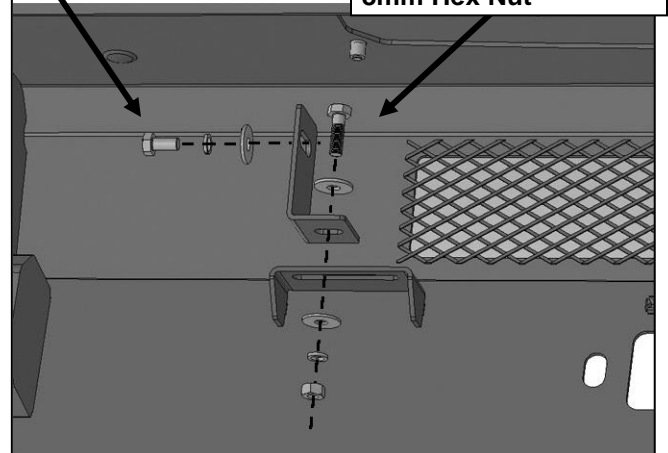

**(Fig 13) Universal LED Brackets (light not included)**

**IMPORTANT:** Sensors fit snug in sockets. The 4mm Screws are only used to apply slight pressure to lock the sensors in place. Tighten both screws evenly until they touch the sensor body only. Do not overtighten screws or damage to sensors will result.

**ELEVATION BULL NOSE FRONT BUMPER  
2010-17 DODGE RAM 2500-3500**

**Driver Side Installation Pictured**

- (3) 12mm x 50mm Hex Bolts
- (6) 12mm Flat Washers
- (3) 12mm Lock Washers
- (3) 12mm Hex Nuts

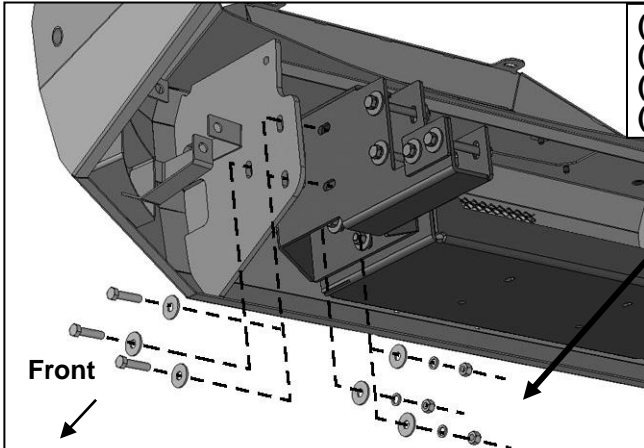

**(Fig 15) Attach Bumper to Mounting Brackets**



**(Fig 16) Attach Bumper to Mounting Brackets**

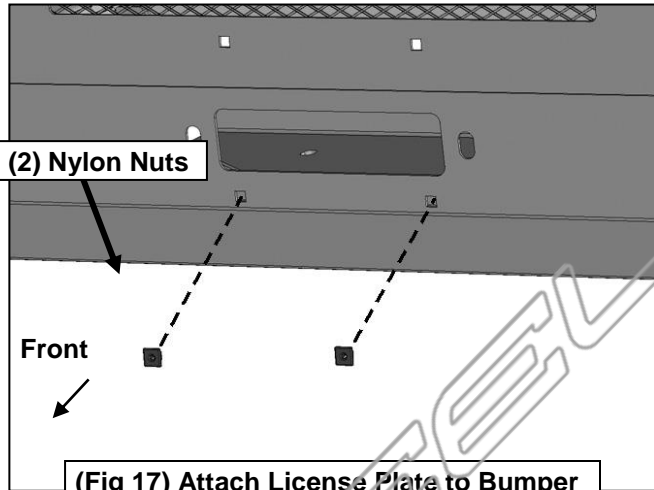

**(Fig 17) Attach License Plate to Bumper**

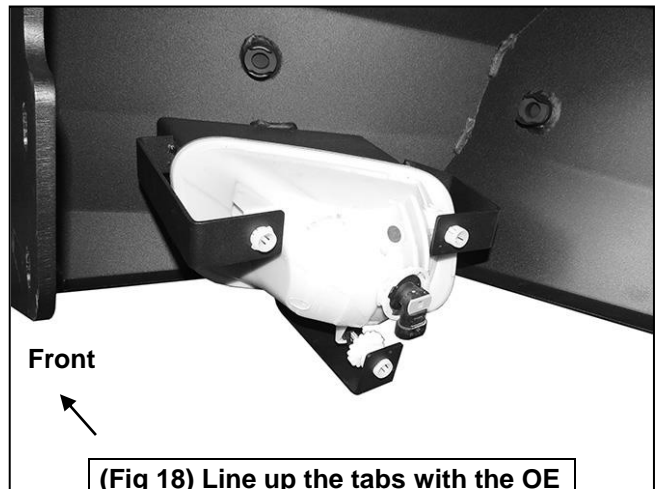

**(Fig 18) Line up the tabs with the OE fog light if equipped. Carefully push the fog light into the mounting tabs**



**Complete Installation**