

**ELEVATION FRONT BUMPER
2016-20 CAN-AM DEFENDER**

PARTS LIST:

1	Elevation Front Bumper	4	10mm Hex Nuts
1	Skid Plate-lower mount	3	8-1.25mm x 25mm Carriage Bolts
1	Frame Mounting Bracket	2	8-1.25mm x 85mm Hex Bolts
2	Spacers	4	8-1.25mm x 25mm Hex Bolts
1	Driver/left LED Light Bracket	2	8-1.25mm x 16mm Hex Bolts
1	Passenger/right LED Light Bracket	17	8mm x 24mm x 2mm Flat Washers
4	10-1.5mm x 30mm Hex Bolts	11	8mm Lock Washers
8	10mm x 27mm x 3mm Flat Washers	9	8mm Hex Nuts
4	10mm Lock Washers		

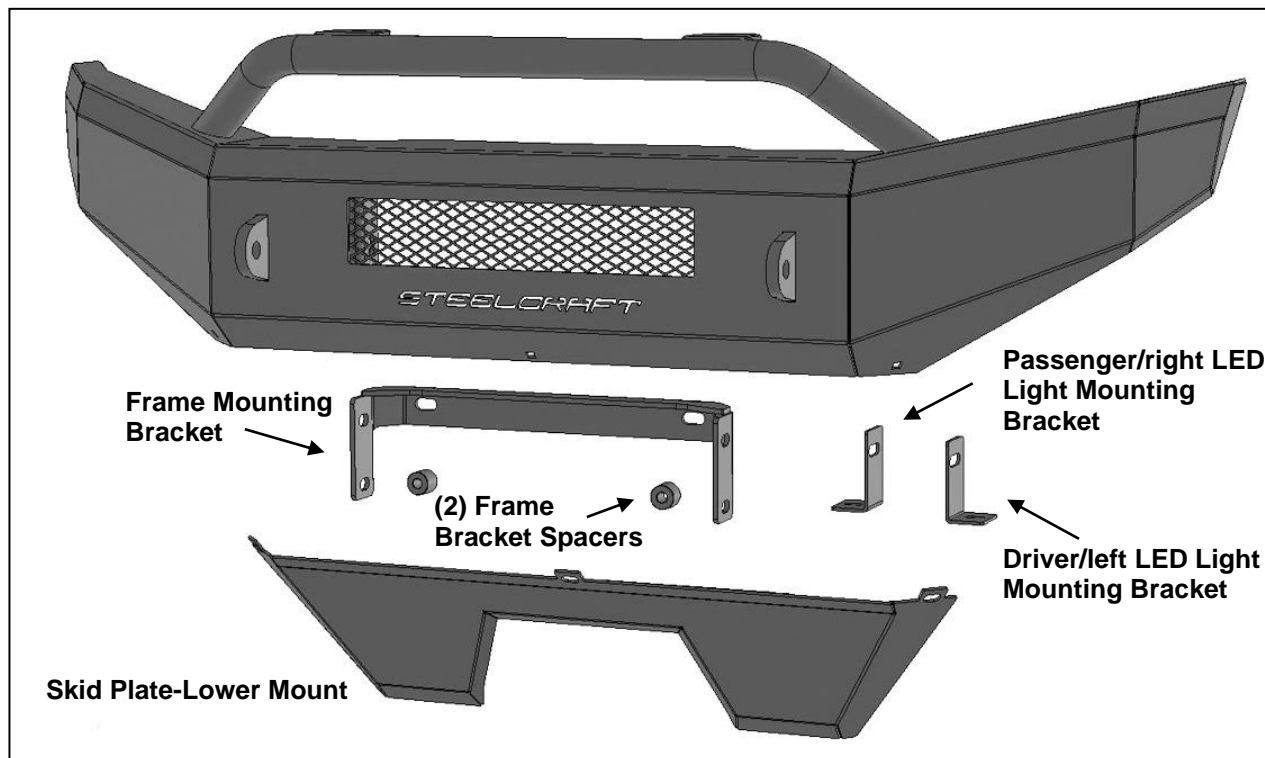

PROCEDURE:

REMOVE CONTENTS FROM BOX. VERIFY ALL PARTS ARE PRESENT. READ INSTRUCTIONS CAREFULLY BEFORE STARTING INSTALLATION. ASSISTANCE IS RECOMMENDED TO AVOID POSSIBLE INJURY OR DAMAGE TO THE VEHICLE.

1. Open the front hood and remove the grille, **(Figure 1)**. Remove the (2) factory bolts from the front crossmember, **(Figures 1, 2 & 4)**. On models equipped with front tube bumper, remove bumper, **(Figure 3)**. **IMPORTANT:** The factory bolts require a T35 Torx tool and may be assembled with thread locking compound, it may be necessary to heat the locking nut to remove. Use caution when removing the factory hardware.
2. Next, Select the Frame Mounting Bracket, **(Figure 5 & 8)**. Insert (1) 8mm x 85mm Hex Bolt with (1) Flat Washer through the back of the hole in the right side of the cross member. **NOTE:** Do not remove factory support spacer in frame, insert long Hex Bolt with Washer through spacer and out through front of crossmember. Slide (1) Outer Spacer onto the Hex Bolt. Attach the Bracket to the front of the cross member with (1) 8mm Flat Washer, (1) 8mm Lock Washer and (1) 8mm Hex Nut. Repeat this Step to attach the left side of the Bracket to cross member. Do not fully tighten hardware.

**ELEVATION FRONT BUMPER
2016-20 CAN-AM DEFENDER**

3. Select the Skid Plate/Lower Mount. Attach the Mount to the front of the frame with (2) 8mm x 25mm Hex Bolts, (4) 8mm Flat Washers, (2) 8mm Lock Washers and (2) 8mm Hex Nuts, **(Figures 6—8)**. Do not fully tighten hardware at this time.
4. Center LED light installation (optional-light sold separately). Install light before installing Bumper.
 - a. Select the Left/Right “L” Brackets, **(Figure 9)**. Attach the Brackets to the top of the (2) mounting tabs welded onto the back of the bumper with the included 8mm x 25mm Hex Bolts, (4) 8mm Flat Washers, (2) 8mm Lock Washers and (2) 8mm Hex Nuts. Leave loose at this time.
 - b. Attach the LED light assembly to the “L” Brackets with the included (2) 8mm x 16mm Hex Bolts, (2) 8mm Lock Washers and (2) 8mm Flat Washers, **(Figure 9)**. Do not fully tighten hardware at this time. **IMPORTANT:** “L” Brackets are designed for 8mm light mounting hardware only. Modify “L” Brackets if necessary or use brackets supplied by the light manufacturer if possible, to install hardware larger than 8mm.
 - c. Follow light manufacturer’s instructions to properly wire the light to the vehicle.
5. With assistance, position the Bumper Assembly up to the outside of the Frame Bracket. Line up the mounting tabs on the back of the Bumper with the slots in the Frame Bracket, **(Figure 10)**. **WARNING:** To avoid possible injury or damage to the vehicle, do not proceed until the Bumper Overlay is fully and safely supported.
6. Attach the Bumper to the Frame Bracket with the included (4) 10mm x 30mm Hex Bolts, (8) 10mm Flat Washers, (4) 10mm Lock Washers and (4) 10mm Hex Nuts, **(Figures 10 & 12)**. Do not fully tighten hardware.
7. Attach the Bumper to the front of the Skid Plate with the included (3) 8mm x 25mm Carriage Bolts, (3) 8mm Flat Washers, (3) 8mm Lock Washers and (3) 8mm Hex Nuts, **(Figures 11 & 12)**. Do not fully tighten hardware.
8. Level and adjust the Bumper and fully tighten all hardware.
9. Reinstall grille.
10. Do periodic inspections to the installation to make sure that all hardware is secure and tight.

To protect your investment, Do not use any type of polish or wax that may contain abrasives that could damage the finish. Mild soap may be used to clean the Bumper assembly.

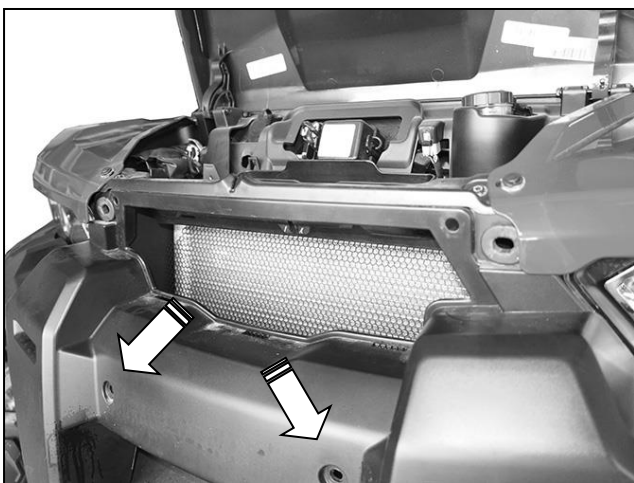

(Fig 1) Remove grille. Remove (2) factory bolts (arrows)

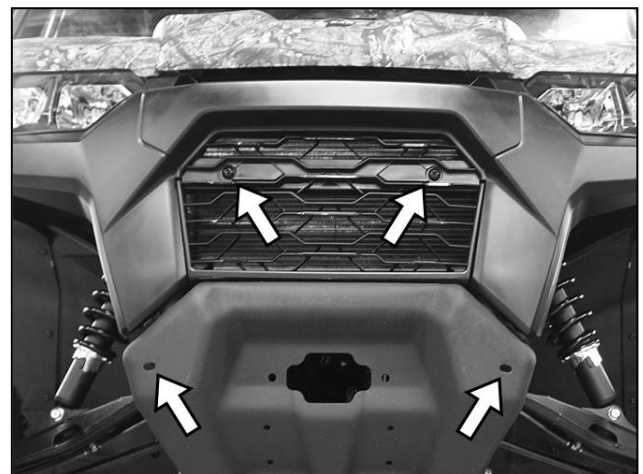

(Fig 2) Remove grille. Remove (2) factory bolts (arrows). 2020 model year pictured

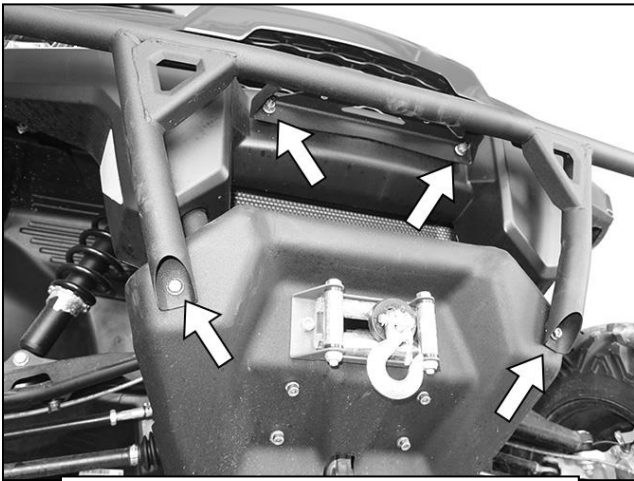

(Fig 3) Models equipped with tube bumper guard, remove guard (arrows)

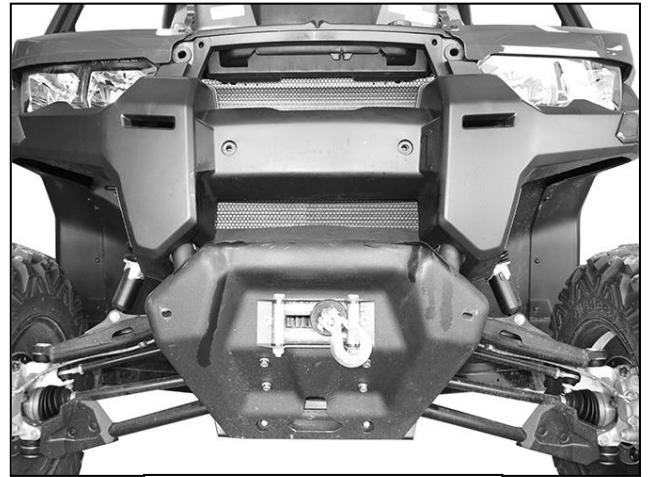

(Fig 4) Hardware removed

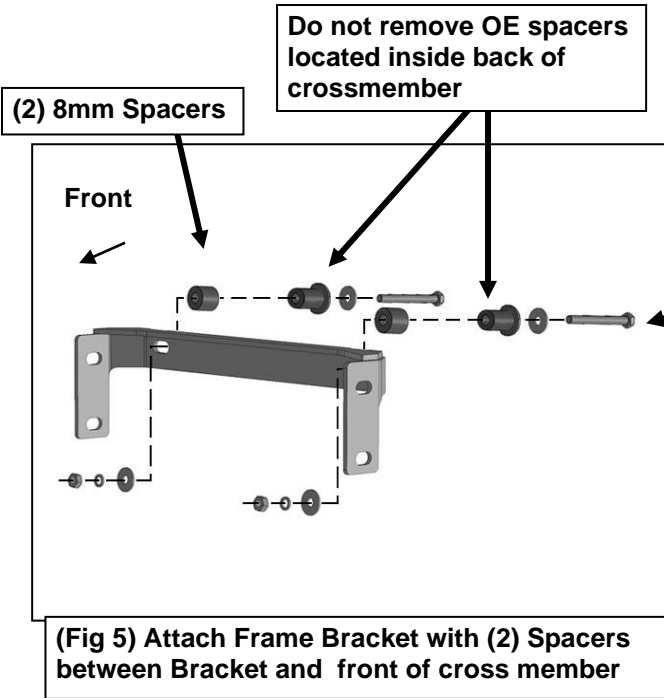

- (2) 8mm x 85mm Hex Bolts**
- (4) 8mm Flat Washers**
- (2) 8mm Lock Washers**
- (2) 8mm Hex Nuts**

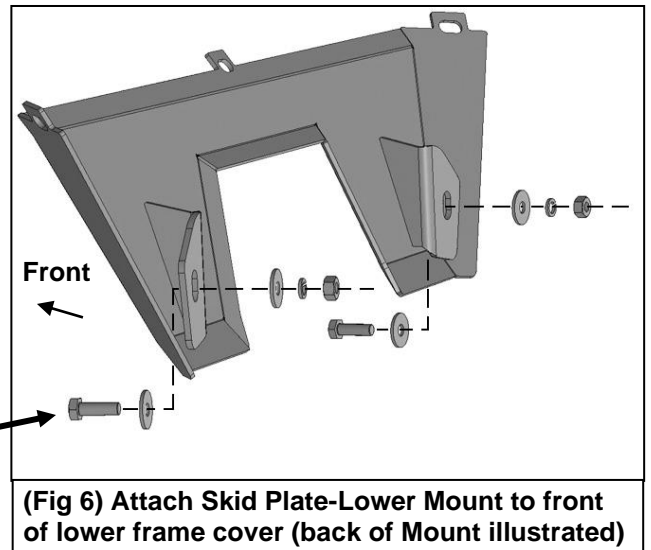

**ELEVATION FRONT BUMPER
2016-20 CAN-AM DEFENDER**

- (2) 8mm x 25mm Hex Bolts
- (4) 8mm Flat Washers
- (2) 8mm Lock Washers
- (2) 8mm Hex Nuts

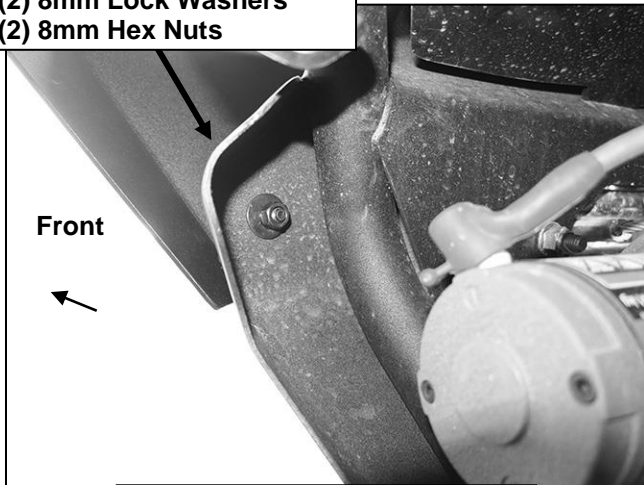

(Fig 7) Driver/left side of Lower Mount attached to frame cover



(Fig 8) Top Frame Bracket and lower Skid Plate-Lower Mount

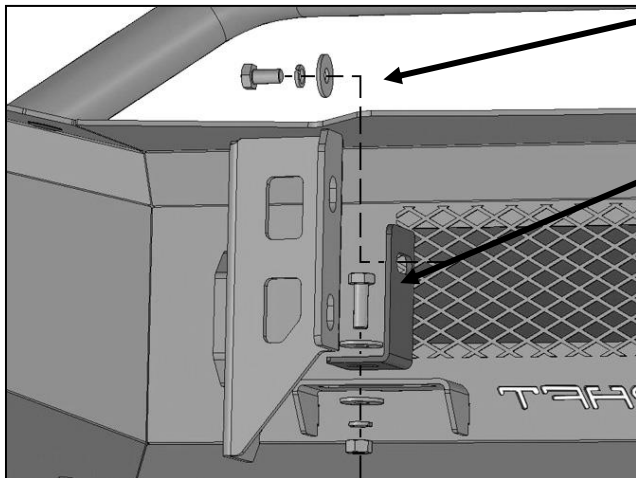

(Fig 9) Attach Left/Right LED Brackets to tabs on back of Bumper (left side illustrated)

- 8mm x 16mm Hex Bolt
- 8mm Lock Washer
- 8mm Flat Washer

- 8mm x 25mm Hex Bolt
- (2) 8mm Flat Washers
- 8mm Lock Washer
- 8mm Hex Nut

- (4) 10mm x 30mm Hex Bolts
- (8) 10mm Flat Washers
- (4) 10mm Lock Washers
- (4) 10mm Hex Nuts

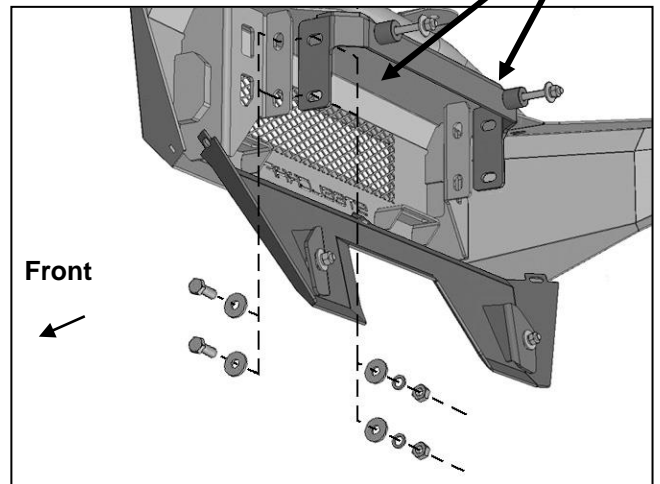

(Fig 10) Attach Bumper to Top Frame Bracket (driver/left side illustrated)

**ELEVATION FRONT BUMPER
2016-20 CAN-AM DEFENDER**

- (3) 8mm x 25mm Carriage Bolts
- (3) 8mm Flat Washers
- (3) 8mm Lock Washers
- (3) 8mm Hex Nuts

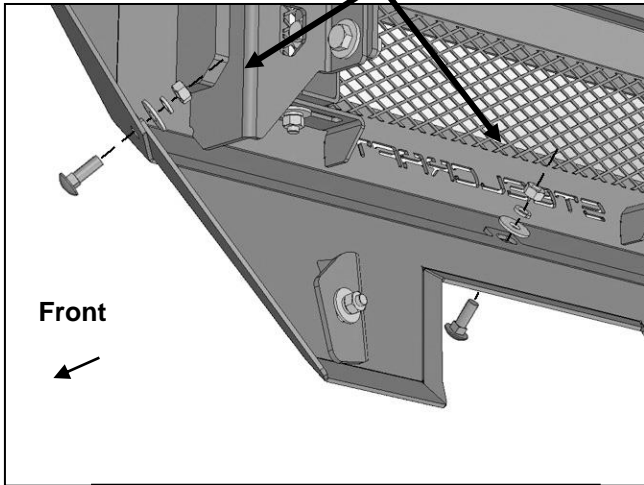

(Fig 11) Attach Bumper to top/front of Lower Skid Plate Mount Bracket



(Fig 12) Driver/left side of Bumper attached to Frame Bracket and Lower Skid Plate Mount Bracket

