

**HD BULL NOSE FRONT BUMPER
2017 FORD SUPER DUTY F250-350**

PARTS LIST:

1	HD Bull Nose Front Bumper	48	12mm x 32mm x 3mm Flat Washers
1	Driver/left Frame Bracket	28	12mm Lock Washers
1	Passenger/right Frame Bracket	28	12-1.75mm Hex Nuts
1	Winch Tray		
1	Access Cover	2	8-1.25mm x 20mm Hex Bolts
2	Plastic Plugs for license plate mount	2	8mm Nylon Lock Nuts
1	Driver/left Upper U-Bracket (OEM fog light)	4	8mm x 24mm x 2mm Flat Washers
1	Passenger/right Upper U-Bracket (OEM fog light)		
2	Lower U-Brackets (OEM fog light only)	5	6mm Combo Button Head Bolts
		4	6mm x 16mm Hex Bolts
		4	6mm x 18mm x 1.6mm Flat Washers
8	12mm x 40mm Bolt Plates	4	6mm Lock Washers
20	12-1.75mm x 50mm Hex Bolts	1	4mm Wrench (6mm Button Head)

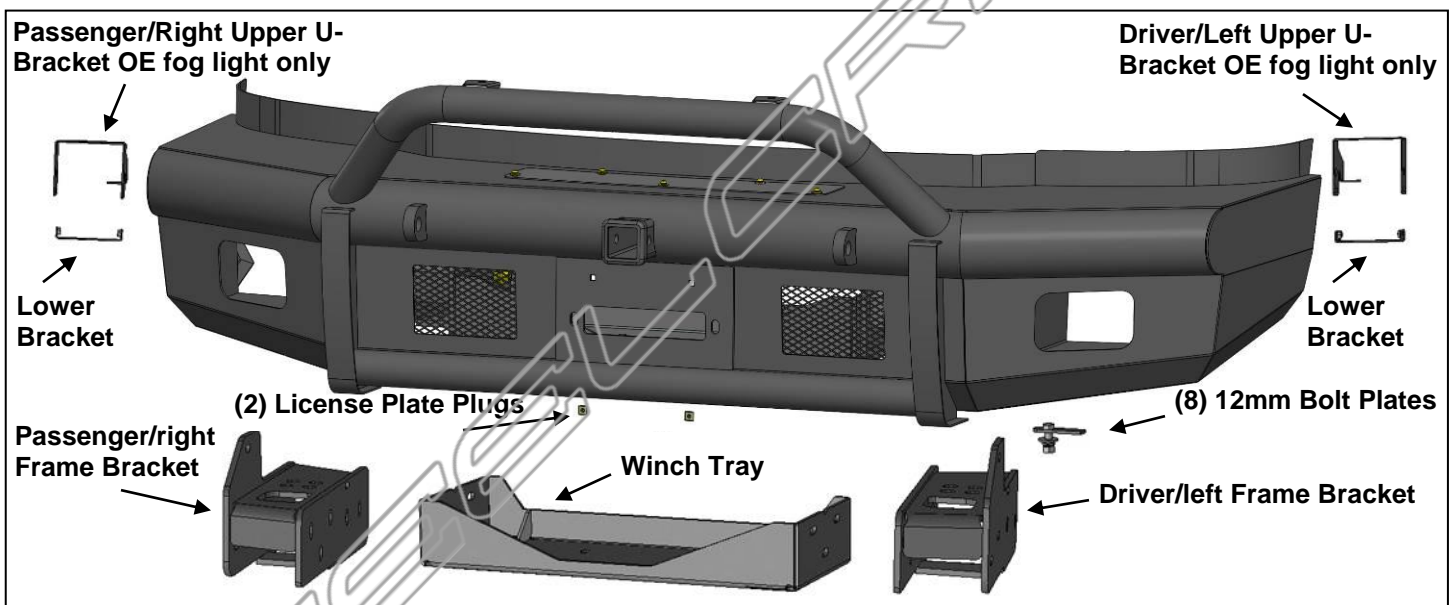

PROCEDURE:

REMOVE CONTENTS FROM BOX. VERIFY ALL PARTS ARE PRESENT. READ INSTRUCTIONS CAREFULLY BEFORE STARTING INSTALLATION. BUMPER IS HEAVY, ASSISTANCE IS HIGHLY RECOMMENDED TO AVOID POSSIBLE INJURY OR DAMAGE TO THE VEHICLE.

1. Remove the license plate and bracket. On models with factory fog lights, unplug both lights and move the wiring harness away from the bumper, **(Figures 1 & 2)**.
2. Next, remove the plastic lower air dam from the bottom of the bumper, **(Figure 3)**. Remove the outer bumper supports attaching the outer ends of the bumper to the sides of the frame, **(Figure 4)**. Remove the plastic covers from the tow hooks to uncover the bumper bolts, **(Figure 5)**.
3. Place blocks or jack stands under the front bumper to support it during mounting bolt removal. Once the bumper has been safely supported, remove the (8) factory bumper bolts, **(Figure 6)**.
WARNING! Assistance is required to hold the bumper in place during bolt removal to prevent the bumper from falling. Carefully slide the bumper off over the tow hooks.
4. Remove the tow hooks from the ends of the frame, **(Figure 7)**. Next, remove the factory hex nuts, lower frame extension and double bolt plates from the ends of the frame, **(Figures 2 & 7)**.

**HD BULL NOSE FRONT BUMPER
2017 FORD SUPER DUTY F250-350**

5. Select the driver/left Frame Bracket, **(Figure 8)**. Slide the Bracket over the end of the frame. Line up the slots in the sides of the Bracket with the holes in the frame. Select (4) 12mm Bolt Plates. Insert the Bolt Plates into the open end of the frame and out through the Bracket. Attach the Bracket to the Bolt Plates with (4) 12mm Flat Washers, (4) 12mm Lock Washers and (4) 12mm Hex Nuts, **(Figures 8 & 10)**. Leave hardware loose at this time.
6. Attach the mounting tab on the top of the Bracket to the top of the frame with the included (4) 12mm x 50mm Hex Bolts, (8) 12mm Flat Washers, (4) 12mm Lock Washers and (4) 12mm Hex Nuts, **(Figures 9 & 10)**. Do not fully tighten hardware at this time.
7. Repeat **Steps 5 & 6** to install the passenger/right Frame Bracket.
8. Next, select the Winch Tray Assembly, **(Figure 11)**. Slide the Winch Tray between the two Brackets. Attach the Winch Tray to the Brackets with (6) 12mm x 50mm Hex Bolts, (12) 12mm Flat Washers, (6) 12mm Lock Washers and (6) 12mm Hex Nuts, **(Figures 11—13)**. Leave hardware loose at this time.
9. If installing winch, attach winch to Winch Tray at this time. Winch must be installed before Bumper is placed in position against Brackets. Also install winch cable guide on Bumper assembly. Follow manufacturer's instructions to properly wire the winch to the electrical system.
10. With assistance, carefully position the Bumper Assembly up to the Brackets. Temporarily support the weight of the Bumper. **WARNING:** To avoid possible injury or damage to the vehicle, do not proceed until the bumper is fully and safely supported.
11. Line up the (3) holes in the driver/left side of the Bumper with the (3) holes in the Frame Bracket. Attach the Bumper to the Bracket with the included (3) 12mm x 50mm Hex Bolts, (6) 12mm Flat Washers, (3) 12mm Lock Washers and (3) 12mm Hex Nuts, **(Figures 14 & 15)**. Do not fully tighten hardware at this time. Repeat to attach the passenger/right side of the Bumper to the Bracket.
12. Level and adjust the bumper and fully tighten all 12mm hardware to 65-70ft-lbs.
13. Use the included (2) push-in plastic nuts to attach the front license plate, (if required), to the (2) holes in the front bumper, **(Figure 16)**.
14. **Models with factory fog lights:**
 - a. Remove the adjustment screw and spring from the fog light assembly, **(Figure 1)**.
 - b. Use a flat blade screwdriver to carefully pop out the tabs on the side of the fog light bracket attaching the light to the bracket. Pop the light out of the plastic bracket housing.
 - c. Select the driver/left top U-Bracket, **(Figure 18)**. Attach the Bracket to the slot in the light opening with (1) 8mm Hex Bolt, (2) 8mm Flat Washers and (1) 8mm Nylon Lock Nut, **(Figure 18)**.
 - d. Carefully spread the sides of the Bracket enough to slide the OE plastic fog light between and into the Bracket, **(Figure 19)**. Select (1) Lower U-Bracket. Attach the Lower Bracket to the Upper Bracket with (2) 6mm Hex Bolts, (2) 6mm Lock Washers and (2) 6mm Flat Washers, **(Figure 20)**.
 - e. Insert the factory spring between the tab on the Bracket and the light. Insert the screw through the tab, spring and into the fog light, **(Figure 20)**.
 - f. Repeat to install the passenger/right fog light.
15. Reattach the factory wiring harness. Adjust lights as necessary and tighten all hardware.
16. Do periodic inspections to the installation to make sure that all hardware is secure and tight.

To protect your investment, wax this product after installing. Regular waxing is recommended to add a protective layer over the finish. Do not use any type of polish or wax that may contain abrasives that could damage the finish. Mild soap may be used to clean the HD Front Bumper assembly.

Driver/Left Side Installation Pictured

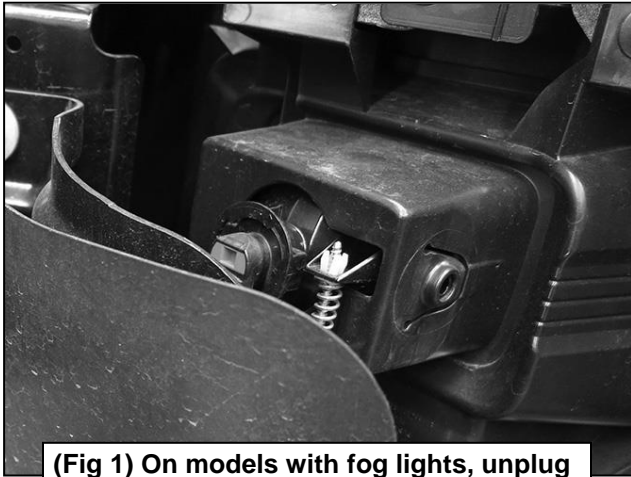

(Fig 1) On models with fog lights, unplug wire harness from back of light

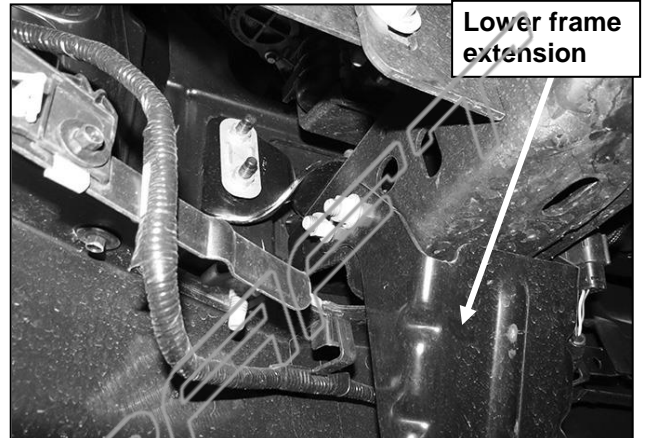

(Fig 2) Release clips attaching the wire harness for fog lights if equipped (driver side)



(Fig 3) Remove plastic air dam from bumper



(Fig 4) Remove outer bumper support brackets between frame and bumper (arrow)

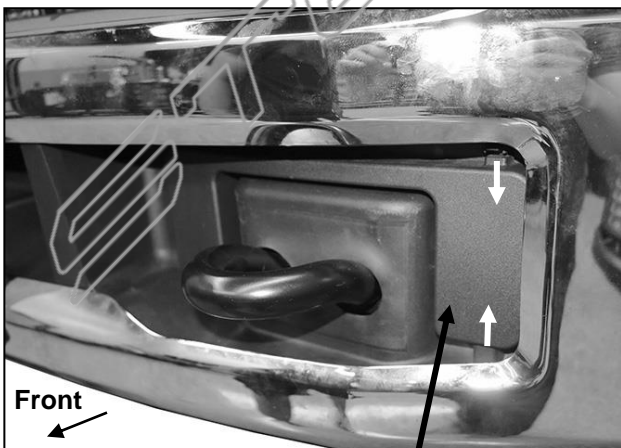

(Fig 5) Remove plastic cover around tow hook by squeezing the top and bottom together.



(Fig 6) Remove bumper bolts (driver side pictured)

WARNING! Do not remove bumper bolts unless the bumper is properly supported on blocks or stands or the bumper may fall.

Driver/Left Side Installation Pictured

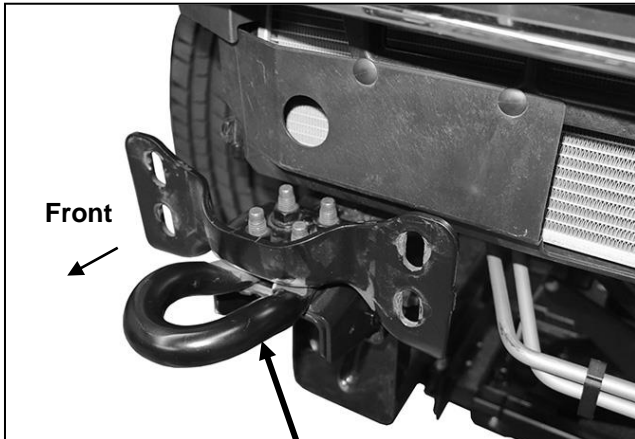

(Fig 7) Remove tow hook assembly and lower frame extension (not pictured-see Fig 2)

WARNING! Do not crawl under bumper unless the bumper is properly supported on blocks or stands or the bumper may fall.

- (4) 12mm Flat Washers
- (4) 12mm Lock Washers
- (4) 12mm Hex Nuts

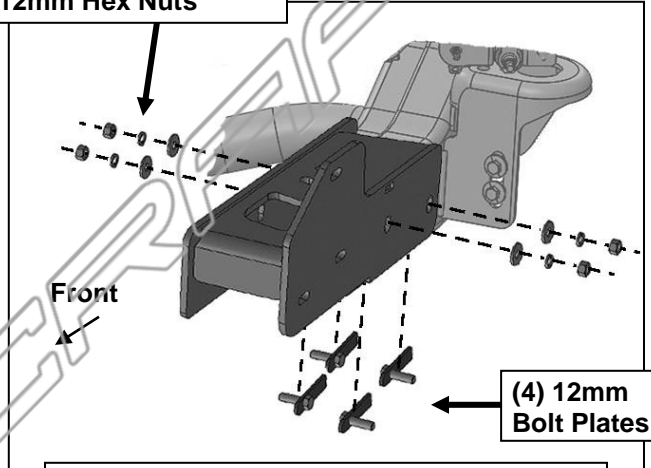

(Fig 8) Insert Bolt Plates into open end of frame. Attach Bracket to sides of frame

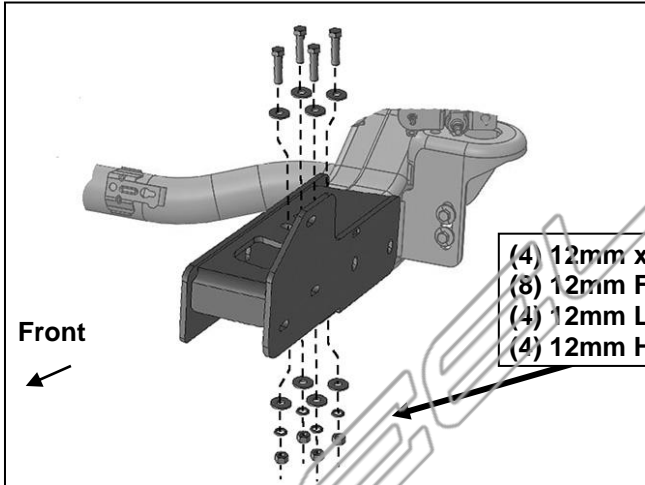

- (4) 12mm x 50mm Hex Bolts
- (8) 12mm Flat Washers
- (4) 12mm Lock Washers
- (4) 12mm Hex Nuts

(Fig 9) Attach top of Bracket to (4) top mounting holes in frame



(Fig 10) Brackets installed

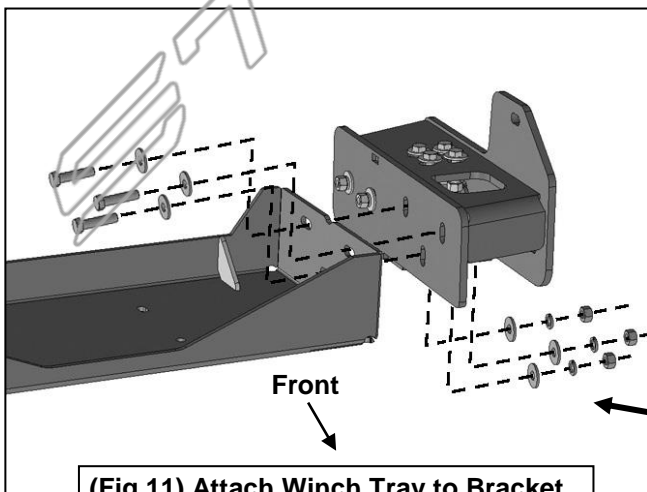

(Fig 11) Attach Winch Tray to Bracket

- (3) 12mm x 50mm Hex Bolts
- (6) 12mm Flat Washers
- (3) 12mm Lock Washers
- (3) 12mm Hex Nuts

Driver/Left Side Installation Pictured

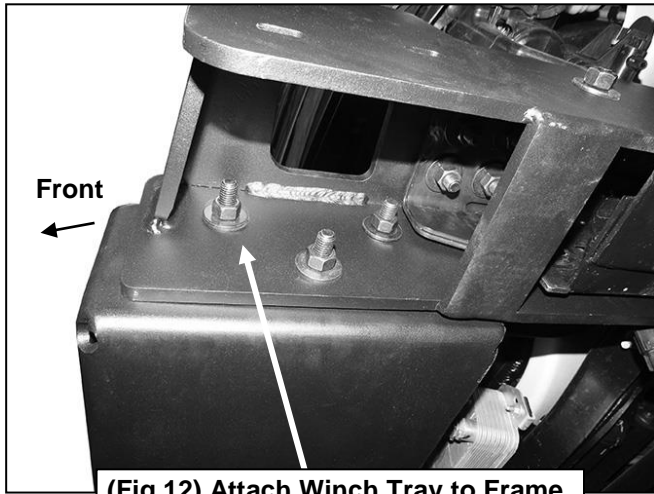

(Fig 12) Attach Winch Tray to Frame Bracket (pictured from below)

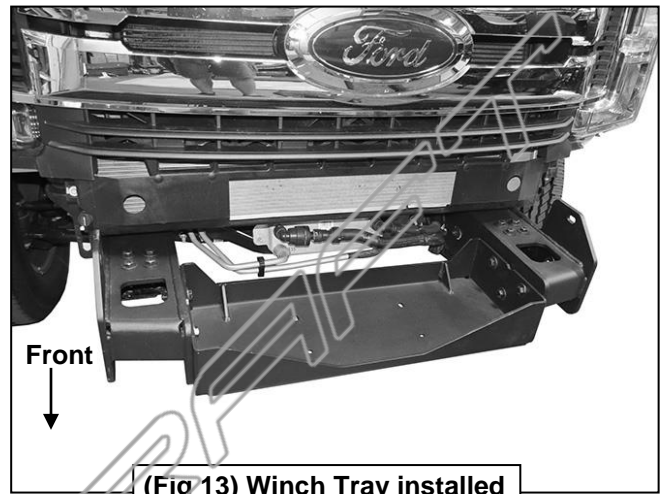

(Fig 13) Winch Tray installed

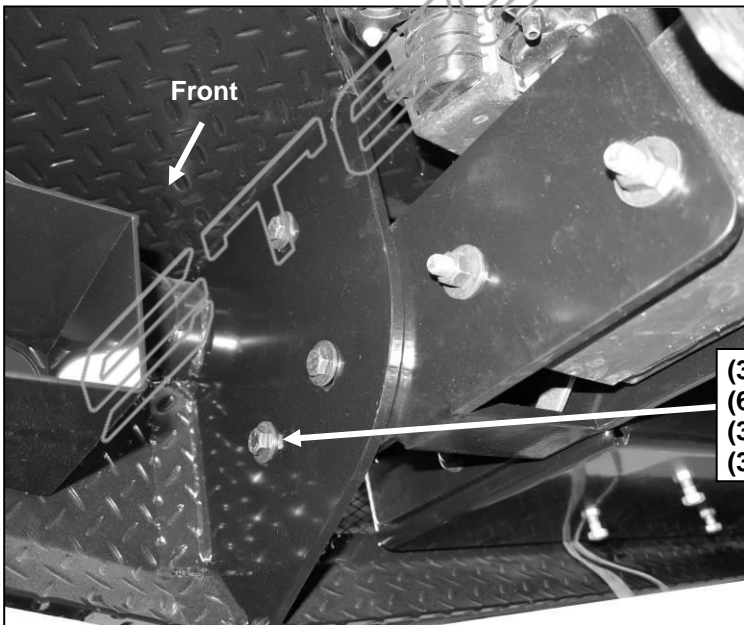

(Fig 15) Attach Bumper to side of Frame Bracket (driver/left side pictured from behind bumper)

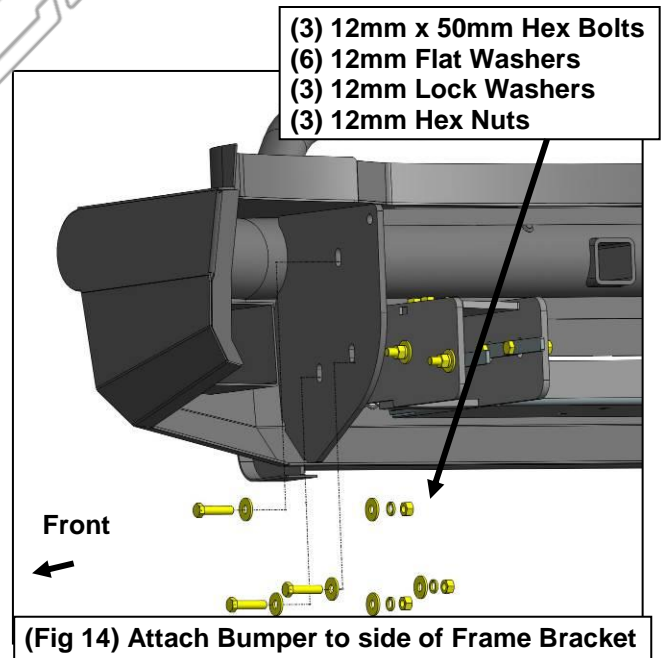

(Fig 14) Attach Bumper to side of Frame Bracket

- (3) 12mm x 50mm Hex Bolts
- (6) 12mm Flat Washers
- (3) 12mm Lock Washers
- (3) 12mm Hex Nuts

WARNING! Do not crawl under bumper unless the bumper is properly supported on blocks or stands or the bumper may fall.

Driver/Left Side Installation Pictured

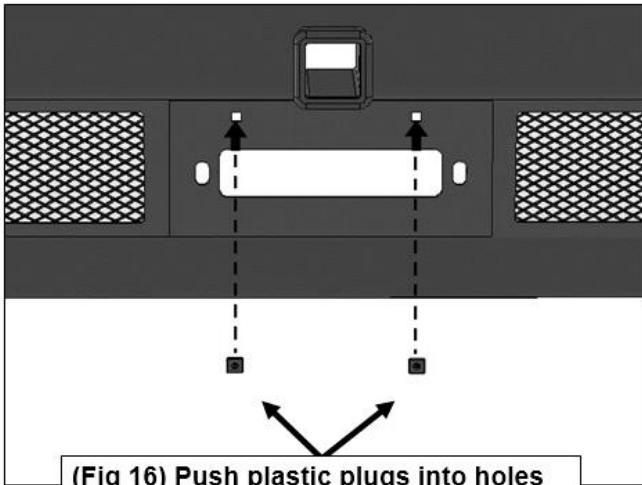

(Fig 16) Push plastic plugs into holes in Bumper for license plate if required

8mm x 20mm Hex Bolt
(2) 8mm Flat Washers
8mm Nylon Lock Nut

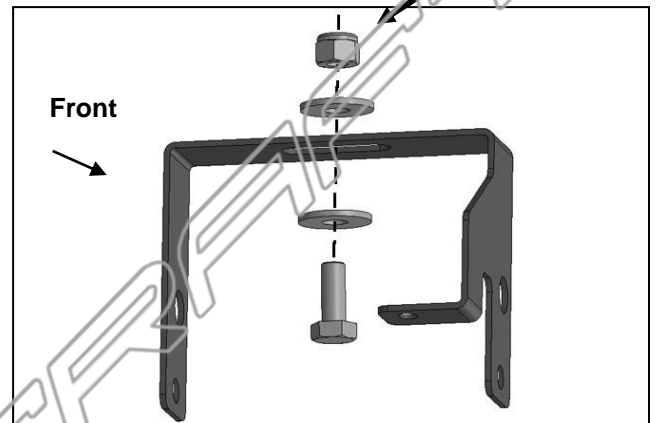

(Fig 17) Optional OEM fog light installation (light not included). Attach driver/left Upper Bracket to the slot in top of the opening

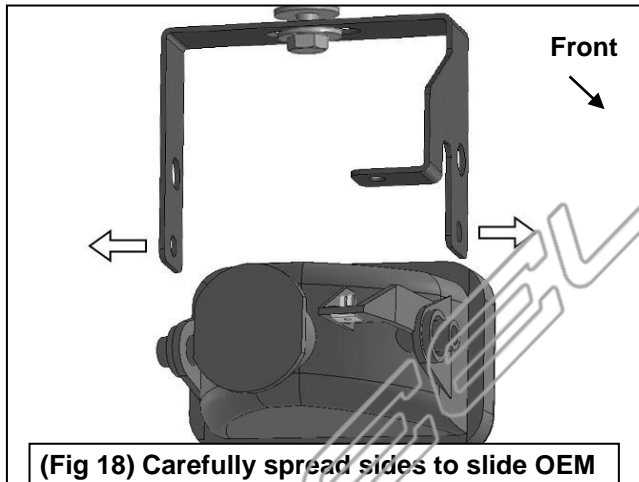

(Fig 18) Carefully spread sides to slide OEM fog light into position in pivot holes

6mm x 16mm Hex Bolt
6mm Lock Washer
6mm Flat Washer

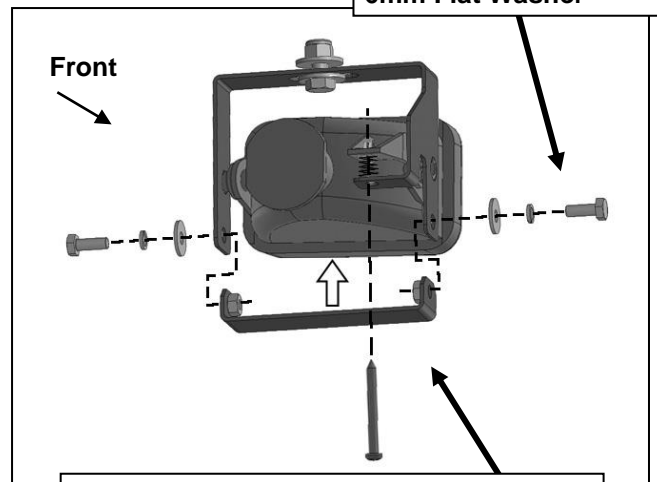

(Fig 19) Attach lower U Bracket to Upper Bracket. Reuse factory adjustment hardware (screw, spring and plastic nut)



Complete Installation