

SKYJACKER

SUSPENSIONS

SKYJACKER.COM

Shock Absorbers

Hydro, Nitro, Black MAX, M95 Monotube
& ADX 2.0 Adventure Series
Installation Instructions

Required Tools List:

- SAE Sockets \ Wrenches
- Metric Sockets \ Wrenches
- Diagonal Cutting Pliers
- Water Resistant Grease
- Safety Glasses
- Jack Stands
- Wheel Chock
- Floor Jack
- Torque Wrench



Before beginning installation, read instructions completely. If you have any questions or reservations about installation, contact Skyjacker® Technical Assistance at 318-388-0816.

Skyjacker® strongly recommends installation be performed by a certified Automotive Technician. Replacement shock absorber installation is a basic Remove & Replace (R&R). Aftermarket shocks require, in most instances, that specific shock mounts be installed prior to proper installation.

Important Notes:

- Shock Absorbers Should Be Replaced in Pairs (Front Pair and \ or Rear Pair).
- Hydro Hydraulic Shock Absorbers Must Be Mounted With Cylinder Body Down \ Rod Mount Up.
- Nitro Gas Charged Shock Absorbers Must Be Mounted With Cylinder Body Down \ Rod Mount Up.
- Black MAX Hydraulic Shock Absorbers Have 180 Degree Directional Mounting, BUT in Certain Applications Shock Mounts Determine Specific Mounting Position.
- M95 Performance Monotube Shock Absorbers Have 180 Degree Directional Mounting, BUT in Certain Applications Shock Mounts Determine Specific Mounting Position.
- ADX 2.0 Adventure Series Aluminum Monotube Shocks that include a Remote Reservoir Have a Supplied Reservoir Clamp. Loosely assemble two (2) supplied reservoir clamps with two (2) supplied hex head bolts using a hex key socket (one (1) front & one (1) back). Position clamp into place around shock body & reservoir cylinder. Secure, but Do Not Completely Tighten.

CAUTION: Make Sure ADX Shock Reservoir \ Reservoir Hose Does Not & Will Not Make Contact with Anything Throughout Full Travel Cycle of Suspension. (Tire \ wheel, frame rail, frame brackets, springs, brake lines, etc.) For proper clearance, it may be necessary to change location or orientation of reservoir on shock body. Use a hex key socket to loosen clamps to position reservoir cylinder as needed. Tighten reservoir clamps once in proper position.

Pre-Installation Tips: Install Shock Boots, Bushings & Sleeves.

1. Install supplied Shock Boot over shock rod mount. Attach boot mount onto shock rod mount. Attach boot mount to cylinder body with supplied Boot Cable Tie. Remove excess cable tie with diagonal cutting pliers.

Tech Note 1: If your shock mount has a pre-installed bar pin, bar pin must be pressed more to one side to allow boot installation. Return bar pin to center after boot is installed.

- Coat supplied Hourglass Bushings with a water resistant grease & press into appropriate shock eye. (Photo # 1)

Coat appropriate supplied Sleeve & press Sleeve into shock eye bushing. (Photo # 2)

Tech Note 2: To determine appropriate supplied Sleeve for your application, insert supplied Sleeve onto OEM mounting hardware to check Internal Diameter (ID) proper size fitment. Some vehicles require different size ID sleeves at each end.

Tech Note 3: Bar Pin Shock Mounts: If application includes a bar pin to be installed into shock mount. Square corners of closed end of bar pin may need to be slightly ground round. It presses into bushings easier. (Photo # 3)

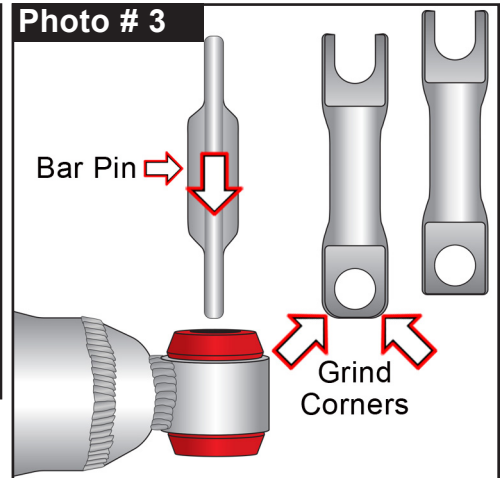
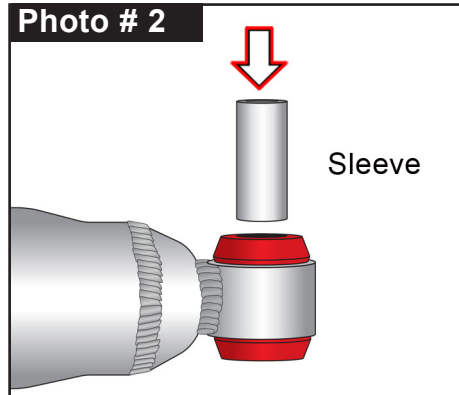
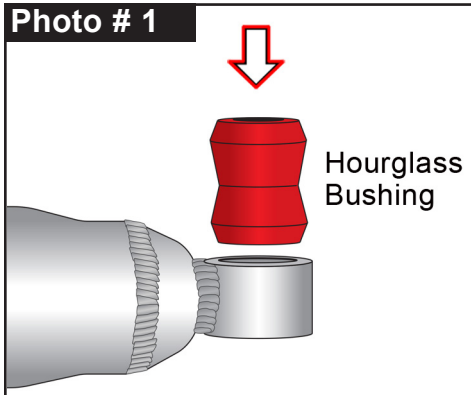

Tech Note 4: Shock Stem Mounts: (Photo # 4A & # 4B)

Note: Stem mount shocks may have a straight stem or a 'shoulder' stem mount that has a wider base.

Install a supplied Cup Washer & Poly Stem Bushing on shock stem base end of Skyjacker Shock. Insert up into OEM mount. Attach with supplied Stem Bushing, Cup Washer & Nut.

Tighten stem nut until stem bushings start to swell slightly.

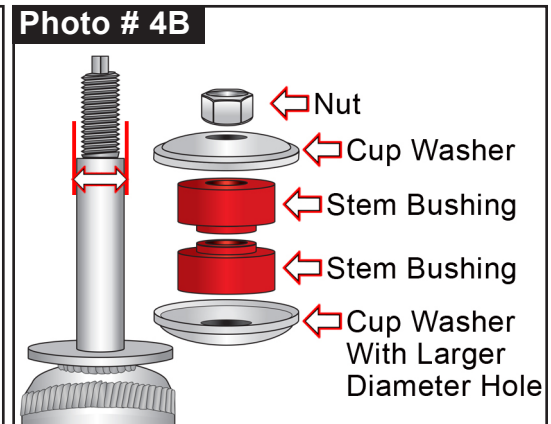
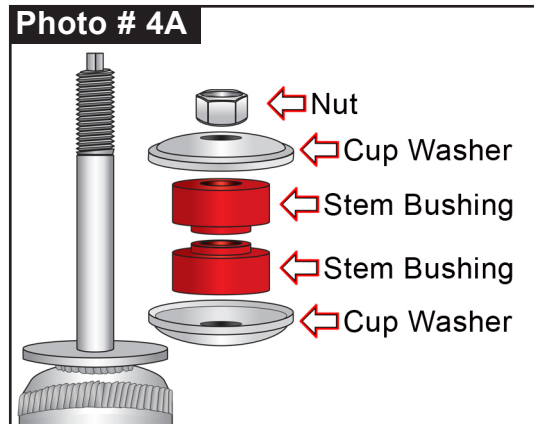

Tech Note 5: Shock Clevis Mounts: (Photo # 5) Connect Skyjacker shock at lower axle mount with OEM hardware.

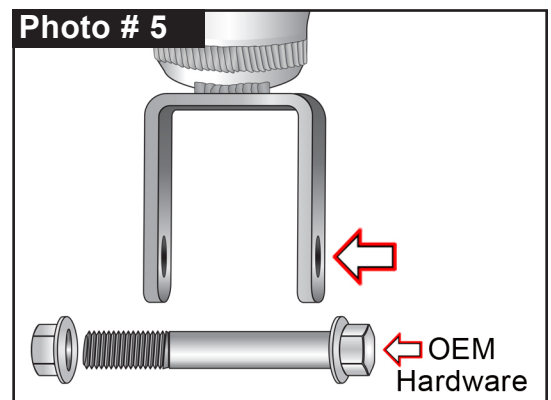

Tech Note 6: Shock Stud Mounts: (Photo # 6) Attach supplied Skyjacker Straight Stud to OEM mount with supplied Lock Washer & Nut using adjustable pliers & a socket \ wrench.

Press shock eye bushing onto stud. Install supplied Flat Washer, Lock Washer & Nut. Tighten nut using socket \ wrench until lock washer is compressed & bushing starts to swell slightly.

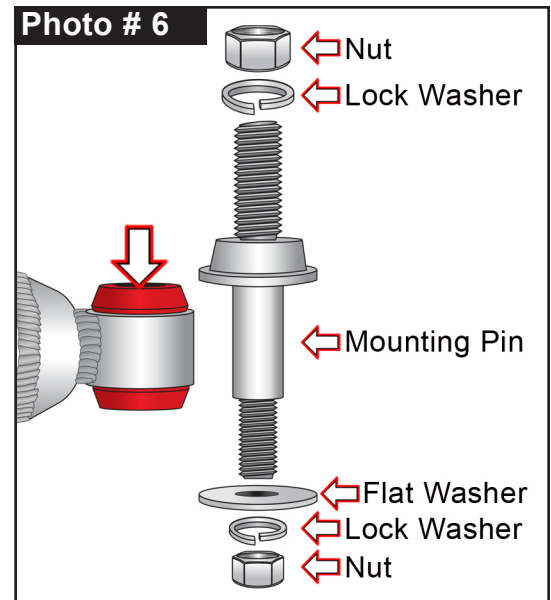

Front Installation: Note: Save all factory components & hardware for reuse, unless noted.

1. With vehicle on flat level ground, set emergency brake & chock rear tires \ wheels.
2. Raise front of vehicle, support frame rails using jack stands at indicated lift points in OEM service manual.
3. Remove front tires \ wheels using a socket.
4. Place a jack under lower control arm or lower ball joint. Raise jack slightly to relieve tension of suspension. Remove OEM front shock.
5. Connect Skyjacker front shock at upper shock mount. Secure, but **Do Not Completely Tighten**. To set bushings properly, these will be tightened once vehicle is on ground with full vehicle weight on tires \ wheels.

Connect Skyjacker shock at lower mount with OEM hardware. Secure, but **Do Not Completely Tighten**.

6. Install front tires \ wheels. Lower front of vehicle to ground.

Rear Installation: Note: Save all factory components & hardware for reuse, unless noted.

1. Chock front tires \ wheels, raise rear of vehicle & support frame rails using jack stands at indicated lift points in OEM service manual.
2. Remove rear tires \ wheels using a socket.
3. Place a jack under axle. Raise jack slightly to relieve tension of suspension. Remove OEM rear shock.
4. Connect Skyjacker front shock at upper shock mount. Secure, but **Do Not Completely Tighten**. To set bushings properly for ride height, these will be tightened once vehicle is on ground with full vehicle weight on tires \ wheels.

Connect Skyjacker shock at lower mount with OEM hardware. Secure, but **Do Not Completely Tighten**.

5. Install rear tires \ wheels. Lower front of vehicle to ground.

Final Steps:

1. Start vehicle. Make sure there are no dash lights pertaining to suspension.
2. Jounce vehicle a couple of times. This will help suspension settle to proper ride height. Cycle steering lock-to-lock & check all components for proper operation & clearances. Pay special attention to clearance between tires \ wheels, shocks, hoses, wiring, etc.

CAUTION: Make Sure ADX Shock Reservoir \ Reservoir Hose Does Not & Will Not Make Contact with Anything Throughout Full Travel Cycle of Suspension. (Tire \ wheel, frame rail, frame brackets, springs, brake lines, etc.) For proper clearance, it may be necessary to change location or orientation of reservoir on shock body. Use a hex key socket to loosen clamps to position reservoir cylinder as needed. Tighten reservoir clamps once in proper position.

3. Tighten & Torque Sequence.

Front shock absorber upper mount. Torque to OEM service manual specifications.

Front shock absorber lower mount. Torque to OEM service manual specifications.

Rear shock absorber upper mount. Torque to OEM service manual specifications.

Rear shock absorber lower mount. Torque to OEM service manual specifications.

Final Notes:

- After installation is complete, double check that all nuts & bolts are tight. Refer to following chart for proper torque specifications.
- After first 100 miles, check all hardware for proper torque & periodically thereafter.

TORQUE SPECIFICATIONS					
INCH SYSTEM			METRIC SYSTEM		
Bolt Size	Grade 5	Grade 8	Bolt Size	Class 8.8	Class 10.9
5/16	180 in-lbs	240 in-lbs	6MM	102 in-lbs	108 in-lbs
3/8	30 ft-lbs	35 ft-lbs	8MM	16 ft-lbs	23 ft-lbs
7/16	45 ft-lbs	60 ft-lbs	10MM	32 ft-lbs	45 ft-lbs
1/2	65 ft-lbs	90 ft-lbs	12MM	55 ft-lbs	75 ft-lbs
9/16	95 ft-lbs	130 ft-lbs	14MM	85 ft-lbs	120 ft-lbs
5/8	135 ft-lbs	175 ft-lbs	16MM	130 ft-lbs	165 ft-lbs
3/4	185 ft-lbs	280 ft-lbs	18MM	170 ft-lbs	240 ft-lbs

**Above Specifications Are Not to Be Used
When Bolt Is Being Installed With a Bushing.**

Seat Belts Save Lives, Please Wear Your Seat Belt.

