

### Required Tools List:

- **SAE Hex Key & SAE Sockets \ Wrenches**  
(5/32" Hex Key Socket & 7/16", 1/2", 9/16", 5/8", 3/4" & 7/8")
- **Metric Hex Key & Metric Sockets \ Wrenches**  
(5mm & 8mm Hex Keys, T45 Torx Bit & 8mm, 10mm, 11mm, 13mm, 15mm, 17mm, 18mm, 19mm, 21mm, 22mm & 27mm)
- **Jack Stands**
- **Wheel Chocks**
- **Safety Glasses**
- **Torque Wrench**
- **Rubber Mallet**
- **Pliers**
- **Power Drill**
- **Reciprocating Saw or Suitable Cutting Tool**
- **Paint \ Undercoating**
- **Plastic Fastener Removal Tool**
- **Floor Jack**
- **Measuring Tape**
- **Paint Marker**
- **Ball Peen Hammer**
- **Standard Screwdriver**
- **Tube Bending Pliers**
- **Drill Bits 13/32" & 1/2"**



Before beginning installation, read these instructions & enclosed driver's WARNING NOTICE thoroughly & completely. Also affix WARNING decal in passenger compartment in clear view of all occupants. Please refer to Parts List to insure that all parts & hardware are received prior to disassembly of vehicle. If any parts are found to be missing, contact SKYJACKER® Customer Service at 318-388-0816 to obtain needed items. If you have any questions or reservations about installing this product, contact SKYJACKER® Technical Assistance at 318-388-0816.

Make sure you park vehicle on a level concrete or asphalt surface. Many times a vehicle is not level (side-to-side) from factory, but is usually not noticed until a lift kit has been installed which makes difference more visible. Using a measuring tape, measure front & rear (both sides) from ground up to center of fender opening above axle. Record this information below for future reference.

Driver Side Front: \_\_\_\_\_ / \_\_\_\_\_  
BEFORE / AFTER

Passenger Side Front: \_\_\_\_\_ / \_\_\_\_\_  
BEFORE / AFTER

Driver Side Rear: \_\_\_\_\_ / \_\_\_\_\_  
BEFORE / AFTER

Passenger Side Rear: \_\_\_\_\_ / \_\_\_\_\_  
BEFORE / AFTER

### Important Notes:

- This Suspension Lift is NOT Designed to Fit the Following Models:
  - Does NOT Fit Single Cab Models.
  - Does NOT Fit Diesel Models.
  - Does NOT Fit Tremor Models.
  - Does NOT Models Equipped with Continuously Controlled Damping (CCD) System.
  - OEM 17 & 18 Inch Wheels Cannot Be Re-Used. 18 Inch or Larger Diameter Wheels Required.
- If Larger Tires (10% More Than OEM Diameter) Are Installed, Speedometer Recalibration Will Be Necessary. Contact Your Local FORD Dealer or an Authorized SKYJACKER® Dealer for Details.
- After Installation, a Qualified Alignment Facility Is Required to Align Vehicle to OEM Specifications.

## Component Box Breakdown:

### Part # F21461A

Item #	Description	Qty
F2146L	STEERING KNUCKLE, LEFT	1
F2146R	STEERING KNUCKLE, RIGHT	1
F1546FCM-B	CROSSMEMBER, FRONT	1
F1546RCM-B	CROSSMEMBER, REAR	1

Item #	Description	Qty
F1546SBL-P	SWAY BAR BRACKET, PA. SIDE	1
F2146DDB-B	FRONT DIFF BRACKET, DR. SIDE	1
F2146PDB-B	FRONT DIFF BRACKET, PA. SIDE	1
F960DRB-B	REAR DIFF BRACKET, DR. SIDE	1

## Component Box Breakdown: 4.5" Lift

### Part # F2145BB (4.5" Lift \ BLACK MAX)

Item #	Description	Qty
F1546SKD-S	DIFFERENTIAL SKID PLATE	1
RB452	DUAL PIN REAR BLOCK, 4.5	2
916X325X11SPU	9/16 X 3-1/4 X 11 U-BOLT	4
H-BOX F2145B	HDWR BOX: F2145B	1
B8560	BLACK MAX SHOCK W/BOOT	2

### Part # F2145BH (4.5" Lift \ HYDRO)

Item #	Description	Qty
F1546SKD-S	DIFFERENTIAL SKID PLATE	1
RB452	DUAL PIN REAR BLOCK, 4.5	2
916X325X11SPU	9/16 X 3-1/4 X 11 U-BOLT	4
H-BOX F2145B	HDWR BOX: F2145B	1
H7060	HYDRO SHOCK W/RED BOOT	2

### Part # F2145BM (4.5" Lift \ M95)

Item #	Description	Qty
F1546SKD-S	DIFFERENTIAL SKID PLATE	1
RB452	DUAL PIN REAR BLOCK, 4.5	2
916X325X11SPU	9/16 X 3-1/4 X 11 U-BOLT	4
H-BOX F2145B	HDWR BOX: F2145B	1
M9560	M95 MONOTUBE SHOCK, M9560	2

### Part # F2145BN (4.5" Lift \ NITRO)

Item #	Description	Qty
F1546SKD-S	DIFFERENTIAL SKID PLATE	1
RB452	DUAL PIN REAR BLOCK, 4.5	2
916X325X11SPU	9/16 X 3-1/4 X 11 U-BOLT	4
H-BOX F2145B	HDWR BOX: F2145B	1
N8060	NITRO SHOCK W/RED BOOT	2

### Part # F2145BX (4.5" Lift \ ADX)

Item #	Description	Qty
F1546SKD-S	DIFFERENTIAL SKID PLATE	1
RB452	DUAL PIN REAR BLOCK, 4.5	2
916X325X11SPU	9/16 X 3-1/4 X 11 U-BOLT	4
H-BOX F2145B	HDWR BOX: F2145B	1
A2079	ADX ADVENTURE SERIES 2.0	2

## Component Box Breakdown: 6" Lift

### Part # F2160BB (6" Lift \ BLACK MAX)

Item #	Description	Qty
F1546SKD-S	DIFFERENTIAL SKID PLATE	1
RB452	DUAL PIN REAR BLOCK, 4.5	2
916X325X13SPU	9/16 X 3-1/4 X 13 U-BOLT	4
H-BOX F2160B	HDWR BOX: F2160B	1
B8579	BLACK MAX SHOCK W/BOOT	2

### Part # F2160BH (6" Lift \ HYDRO)

Item #	Description	Qty
F1546SKD-S	DIFFERENTIAL SKID PLATE	1
RB452	DUAL PIN REAR BLOCK, 4.5	2
916X325X13SPU	9/16 X 3-1/4 X 13 U-BOLT	4
H-BOX F2160B	HDWR BOX: F2160B	1
H7079	HYDRO SHOCK W/RED BOOT	2

### Part # F2160BM (6" Lift \ M95)

Item #	Description	Qty
F1546SKD-S	DIFFERENTIAL SKID PLATE	1
RB452	DUAL PIN REAR BLOCK, 4.5	2
916X325X13SPU	9/16 X 3-1/4 X 13 U-BOLT	4
H-BOX F2160B	HDWR BOX: F2160B	1
M9579	M95 MONOTUBE SHOCK, M9579	2

### Part # F2160BN (6" Lift \ NITRO)

Item #	Description	Qty
F1546SKD-S	DIFFERENTIAL SKID PLATE	1
RB452	DUAL PIN REAR BLOCK, 4.5	2
916X325X13SPU	9/16 X 3-1/4 X 13 U-BOLT	4
H-BOX F2160B	HDWR BOX: F2160B	1
N8079	NITRO SHOCK W/RED BOOT	2

### Part # F2160BX (6" Lift \ ADX)

Item #	Description	Qty
F1546SKD-S	DIFFERENTIAL SKID PLATE	1
RB452	DUAL PIN REAR BLOCK, 4.5	2
916X325X13SPU	9/16 X 3-1/4 X 13 U-BOLT	4
H-BOX F2160B	HDWR BOX: F2160B	1
A2079	ADX ADVENTURE SERIES 2.0	2

## Hardware Box Breakdown:

### Part # H-BOX F2145B (4.5" Lift)

Item #	Description	Qty
CBL255-B	CARRIER BEARING LWR BRKT	1
F1546RCM-8	CROSSMEMBER BRACE, REAR	1
F945MS-S	STRUT SPACER, FRONT 4.5 INCH	2
F960DSS-S	DRIVESHAFT SPACER, FRONT	1
HB-F2146-BLE	HDWR BAG: BRAKE LINE BRKTS	1
HB-F1546-CBL	HDWR BAG: CARRIER BEARING	1
HB-F1546-CM	HDWR BAG: CROSSMEMBER	1

Item #	Description	Qty
HB-F946-MS	HDWR BAG: STRUT SPACER, FRT	1
HB-F960-DB	HDWR BAG: DIFF BRACKETS	1
HB-F960-DSS	HDWR BAG: DRIVESHAFT SPACER	1
HB-F960-SBL	HDWR BAG: SWAY BAR	1
HB-CARBSKD	HDWR BAG: SKID PLATE	1
HB-916	HDWR BAG: 9/16 LOCK NUT	1

### Part # H-BOX F2160B (6" Lift)

Item #	Description	Qty
CBL255-B	CARRIER BEARING LWR BRKT	1
F1546RCM-8	CROSSMEMBER BRACE, REAR	1
F960MS-S	STRUT SPACER, FRONT 6 INCH	2
F960DSS-S	DRIVESHAFT SPACER, FRONT	1
HB-F2146-BLE	HDWR BAG: BRAKE LINE BRKTS	1
HB-F1546-CBL	HDWR BAG: CARRIER BEARING	1
HB-F1546-CM	HDWR BAG: CROSSMEMBER	1

Item #	Description	Qty
HB-F946-MS	HDWR BAG: STRUT SPACER, FRT	1
HB-F960-DB	HDWR BAG: DIFF BRACKETS	1
HB-F960-DSS	HDWR BAG: DRIVESHAFT SPACER	1
HB-F960-SBL	HDWR BAG: SWAY BAR	1
HB-CARBSKD	HDWR BAG: SKID PLATE	1
HB-916	HDWR BAG: 9/16 LOCK NUT	1

## Hardware Bags Breakdown:

### Part # HB-F2146-BLE

Item #	Description	Qty
BTIE-K	BLACK PLASTIC CABLE TIE	4
DVL10	BRAKE LINE BRACKET, FLAT	1
F11BE-D	BRAKE LINE EXT BRACKET, DR	1
F11BE-P	BRAKE LINE EXT BRACKET, PA	1
VH51610	VENT HOSE: 5/16 X 10 LONG	1
14X1FTB	1/4 X 1 FINE THREAD BOLT	1
14FTN	1/4 FINE THREAD N/I LOCK NUT	1
14SAEW	1/4 SAE WASHER	2

### Part # HB-F1546-CBL

Item #	Description	Qty
10MMX90MMB	10MM X 90MM METRIC BOLT	2
38SAEW	3/8 SAE WASHER	2

### Part # HB-F1546-CM

Item #	Description	Qty
18X150MMB	18MM X 150MM METRIC BOLT	2
18X50MMB	18MM X 50MM METRIC BOLT	2
18MMN	18MM METRIC N/I LOCK NUT	4
34SAEW	3/4 SAE WASHER	8
38X114FTB	3/8 X 1-1/4 FINE THREAD BOLT	2
38SAEW	3/8 SAE WASHER	4
38FTN	3/8 FINE THREAD N/I LOCK NUT	2
12X112FTB	1/2 X 1-1/2 FINE THREAD BOLT	4
12X214FTB	1/2 X 2-1/4 FINE THREAD BOLT	2
12SAEW	1/2 SAE WASHER	12
12FTN	1/2 FINE THREAD N/I LOCK NUT	6
CS8125	CRUSH SLEEVE, 13/16 X-MEMBER	2

## Hardware Bags Breakdown:

### Part # HB-F946-MS

Item #	Description	Qty
10MMX1.5NFN	10MM NYLON FLANGE NUT	6
10MMX30CARB	10MM X 30MM CARRIAGE BOLT	6
10MMPN	10MM PUSH NUT	6

### Part # HB-F960-DB

Item #	Description	Qty
14X90MMB	14MM X 90MM METRIC BOLT	3
14MMN	14MM METRIC N/I LOCK NUT	3
916SAEW	9/16 SAE WASHER	2

### Part # HB-F960-DSS

Item #	Description	Qty
10X80SHB	10 X 80MM SOCKET HEAD BOLT	6
LT100	THREAD LOCK COMPOUND TUBE	1

### Part # HB-F960-SBL

Item #	Description	Qty
716X112FTB	7/16 X 1-1/2 FINE THREAD BOLT	2
716FTN	7/16 FINE THREAD N/I LOCK NUT	2
716SAEW	7/16 SAE WASHER	4

### Part # HB-CARDSKD

Item #	Description	Qty
516X1CARB	5/16 X 1 CARRIAGE BOLT	4
516CTN	5/16 COARSE THRD N/I LOCK NUT	4
516SAEW	5/16 SAE WASHER	4

### Part # HB-916

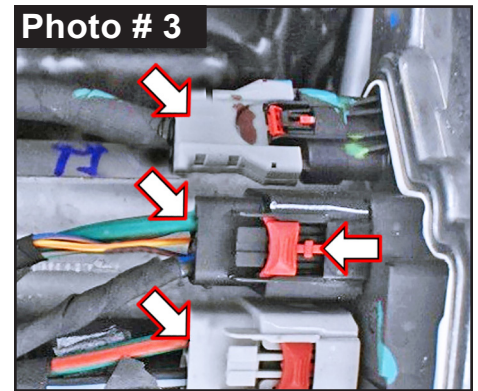
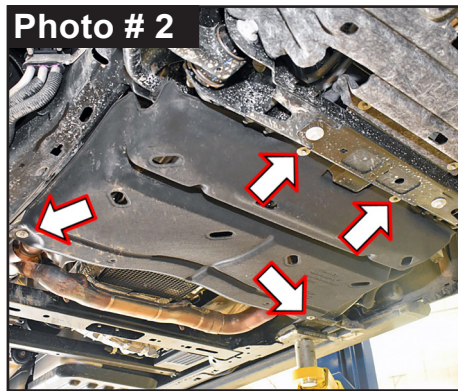
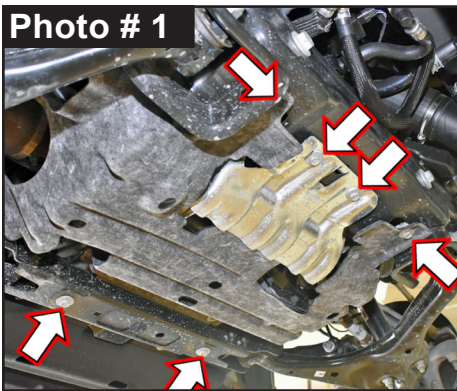
Item #	Description	Qty
916FTN	9/16 FINE THREAD N/I LOCK NUT	8

**Front Installation: Note: Save all factory components & hardware for reuse, unless noted.**

1. With vehicle on flat level ground, set emergency brake & chock rear tires \ wheels.
2. Raise front of vehicle, support frame rails using jack stands at indicated lift points in OEM service manual.
3. Remove front tires \ wheels using a 21mm socket.
4. If equipped, remove aluminum OEM lower skid plate by removing two (2) front bolts using a 13mm socket \ wrench. (See Photo # 1) Remove soft material OEM lower skid plate by removing four (4) front bolts using a 15mm socket \ wrench. Discard both skid plates.
5. If equipped, remove OEM lower splash guard by removing four (4) front bolts from crossmembers with a 8mm socket \ wrench. (See Photo # 2) Discard splash guard.

**Note:** Disconnect Electric Power Assist Steering (EPAS) connector. Sudden jar of a hammer blow or impact wrench to other suspension components could cause contacts of EPAS internal power relay to arch or short out.

6. Disconnect three (3) EPAS plugs on steering assembly next to front differential. (See Photo # 3) **Tech Note:** Red safety lock clip must be slid rearward to unlock. Press & hold rearward tang down, grab connector & pull away while from plug-in.

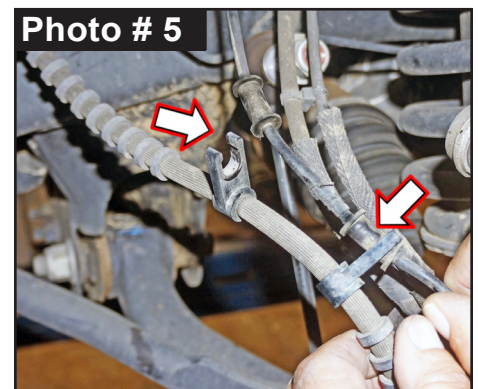
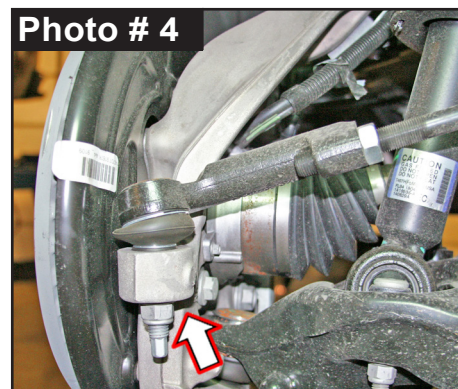


**Note:** Perform Steps 7-23 on One Side at a Time. Complete Steps on One Side, THEN Go to Opposite Side & Repeat Same Steps.

7. Loosen, but do not remove OEM tie rod nut from OEM knuckle using a 21mm socket \ wrench. (See Photo # 4) To unseat tie rod taper, strike tie rod boss of knuckle at tie rod end with ball peen hammer to dislodge.

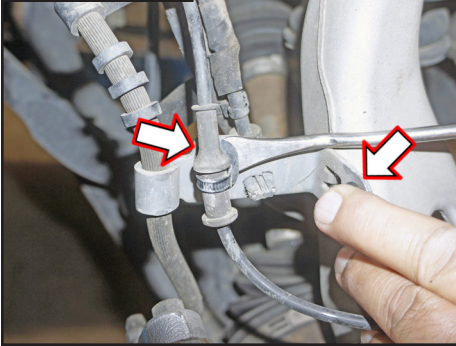
**Note:** ONLY strike knuckle portion. Remove nut & remove tie rod end from knuckle.

8. Disconnect OEM ABS & 4WD actuator lines from two (2) frame points at UCA using a fastener removal tool. Disconnect OEM ABS sensor line from plastic connector clips on OEM brake line. (See Photo # 5)

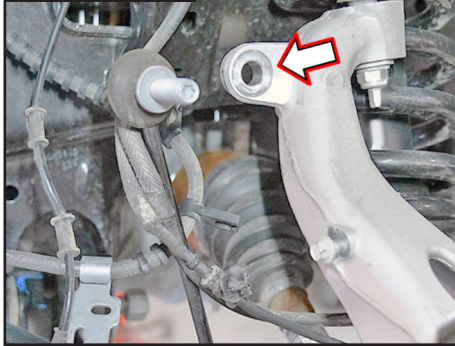


9. On rearward side of OEM knuckle, disconnect OEM ABS sensor line & 4WD actuator line retaining clips from brake line bracket & frame mounts using a plastic fastener removal tool. Disconnect OEM brake line bracket using a 10mm socket \ wrench. (See Photo # 6)
10. Disconnect OEM sway bar end link from OEM knuckle using a T45 Torx bit & a 21mm socket \ wrench. (See Photo # 7)
11. Remove two (2) brake caliper mounting bolts & remove brake caliper from OEM knuckle using a 21mm socket \ wrench. (See Photo # 8) **Tech Note:** Hang brake caliper on frame out of way with a hook or bungee. **Do Not** hang by rubber brake line.

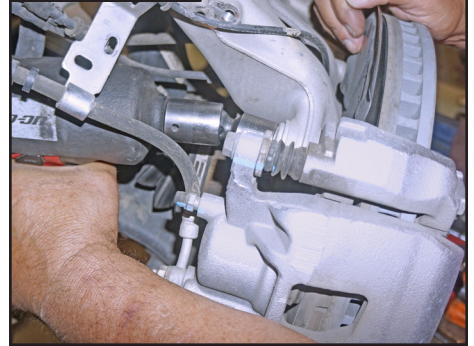
**Photo # 6**



**Photo # 7**



**Photo # 8**



12. Remove OEM brake rotor. Remove CV shaft nut dust cover from center of hub assembly with a standard screwdriver. Remove CV shaft nut using a 13mm socket. (See Photo # 9) Disconnect axle from knuckle. **Note:** Do Not Overextend CV Axle Shaft.
13. Remove three (3) bolts & remove OEM disc brake shield using a 8mm socket \ wrench. (See Photo # 10)
14. Disconnect ABS sensor bracket from outward side of OEM knuckle using a 5mm hex key wrench. (See Photo # 11)

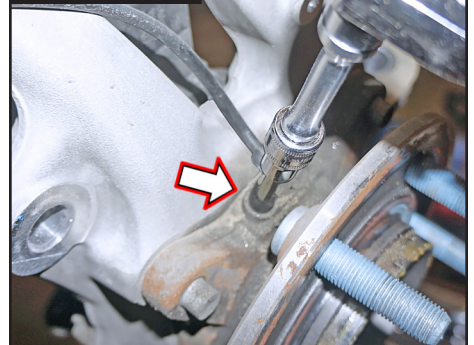
**Photo # 9**



**Photo # 10**

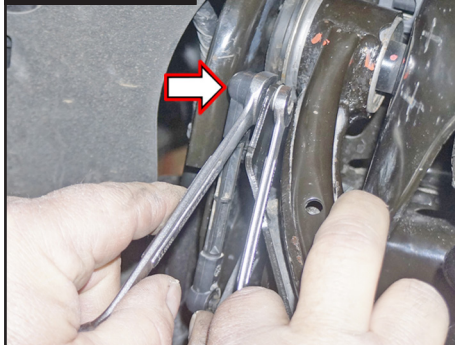


**Photo # 11**

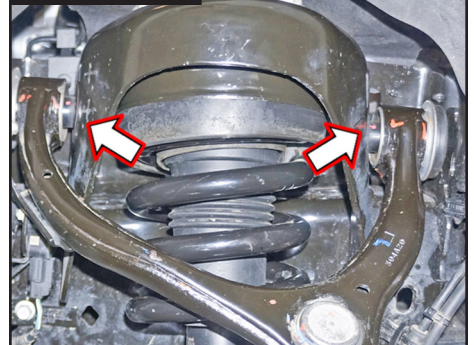


15. If equipped, disconnect OEM ball link from driver side OEM upper control arm using a 8mm & 11mm wrench. (See Photo # 12)
16. Loosen, but do not remove bolts securing OEM upper control arm to frame using a 18mm & 21mm socket \ wrench. (See Photo # 13)

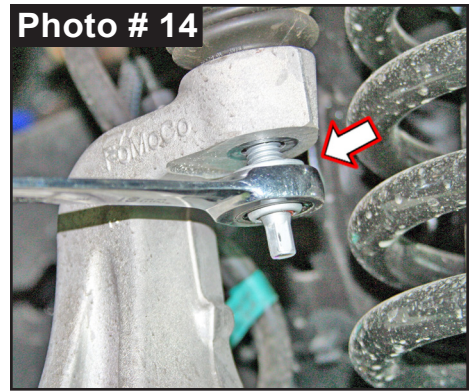
**Photo # 12**



**Photo # 13**



17. Support OEM lower control arm with a jack. Loosen, but do not remove upper OEM ball joint nut from OEM knuckle using an 8mm wrench & a 21mm wrench. (See Photo # 14) To unseat ball joint taper, strike ball joint boss of knuckle with ball peen hammer to dislodge.

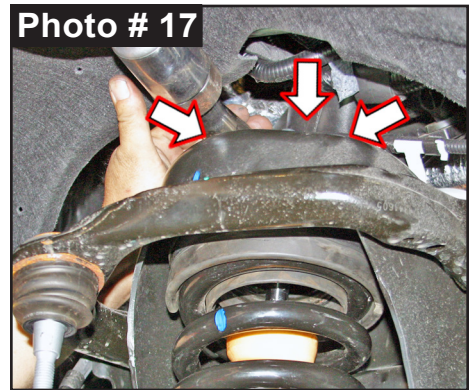
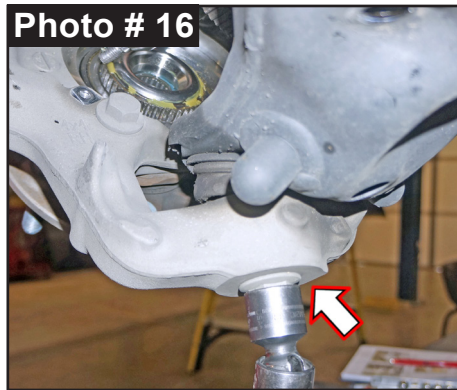
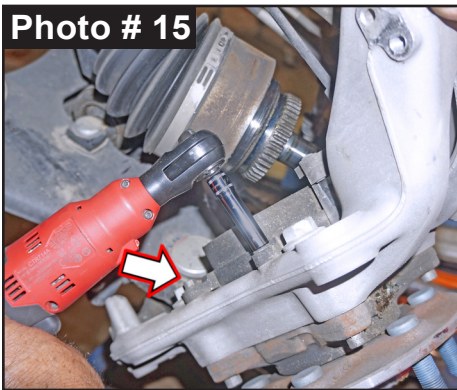


**Note:** ONLY strike knuckle portion. Remove nut & remove ball joint from knuckle. Ease knuckle outward to rest back away from front strut assembly.

18. **Note:** Some models will not have 4WD actuator hub assembly after 2022. Skip this step if not equipped. Remove four (4) OEM 4WD actuator bolts from rearward side of OEM knuckle. (See Photo # 15) **Tech Note:** Carefully remove & hang actuator on frame out of way with a hook or bungee.

19. Loosen, but do not remove OEM lower control arm ball joint nut from OEM knuckle using a 21mm wrench. (See Photo # 16) To unseat ball joint taper, strike ball joint boss of knuckle with ball peen hammer to dislodge. **Note:** ONLY strike knuckle portion. Remove nut & remove ball joint from knuckle. Remove knuckle \ hub assembly.

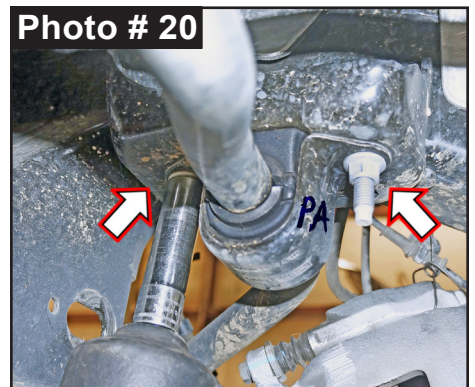
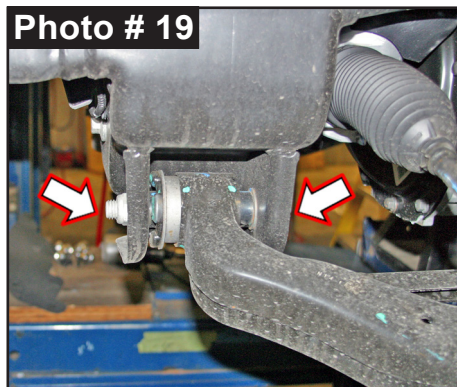
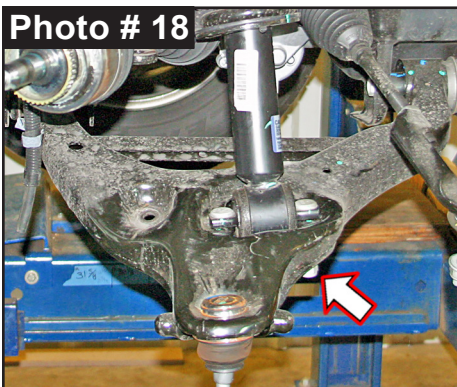
20. Remove three (3) OEM upper strut mounting nuts from frame mount using a 15mm socket \ wrench. (See Photo # 17) **Note:** Do Not remove center strut rod nut.



21. Remove two (2) OEM lower strut mount nuts from bottom side of OEM lower control arm using a 18mm socket \ wrench. (See Photo # 18) Remove OEM strut assembly.

22. Remove OEM lower control arm front & rear mounting hardware using a 21mm socket \ wrench & a 27mm socket \ wrench. (See Photo # 19) Remove OEM lower control arm. Retain arm & hardware for later use.

23. Mark Driver & Passenger side orientation of sway bar body. Disconnect OEM sway bar mounting brackets from frame using a 15mm socket \ wrench. (See Photo # 20) Remove sway bar from vehicle. Remove sway bar stud plates & nuts from each side & retain for later use.



**Note:** Perform Steps 7-23 on Opposite Side at this Time.

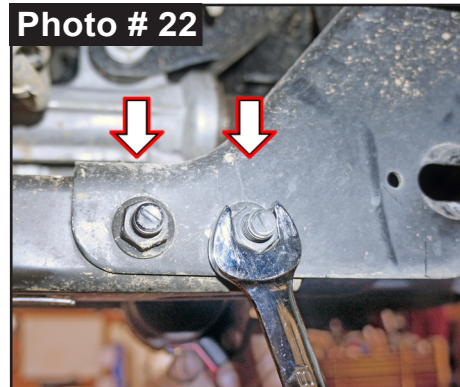
24. For proper reassembly realignment, mark position of OEM front differential flange & OEM driveshaft flange. (See Photo # 21)

Remove six (6) OEM front driveshaft mounting bolts from OEM front differential using a 10mm socket \ wrench. Remove retaining rings & retain for later use.

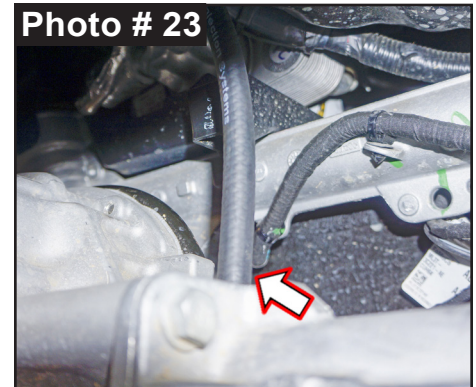
**Tech Note:** Hang driveshaft on frame out of way with wire or a bungee strap.



25. Remove four (4) OEM rear crossmember frame connecting bolts using a 15mm socket \ wrench. (See Photo # 22)  
Remove OEM rear crossmember. Retain hardware for later use.



26. Disconnect OEM differential vent tube from OEM differential. (See Photo # 23) **Tech Note:** Vent tube is located on top of center section towards middle of vehicle.



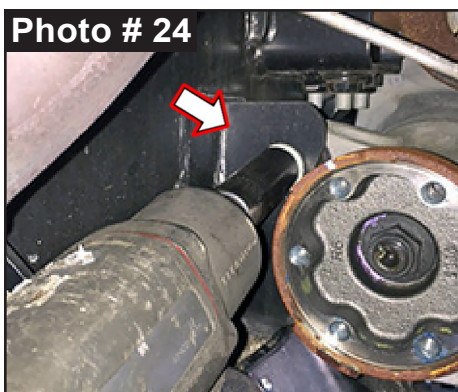
27. Support OEM front differential with a transmission jack, then remove OEM differential mounting bolts.

Remove driver rear differential bolt using a 21mm socket \ wrench. (See Photo # 24)

Remove driver front differential bolt using a 18mm socket \ wrench. (See Photo # 25)

Remove passenger front differential bolt using a 18mm socket \ wrench. (See Photo # 26)

Once these bolts are removed, carefully lower differential assembly out of vehicle.



28. It will now be necessary to cut OEM rear crossmember for differential clearance when lift is installed. **CAUTION:** When using a power cutting tool or plasma cutter, beware of sparks & undercoating. Take precautions to cover yourself, vehicle & floor from this extremely HOT material.

Locate Driver OEM Rear Crossmember Mount Bracket. You will be removing sections of factory mount to be able to install Skyjacker crossmember. (See Photos # 30 & 32)

On Forward Outer Edge of OEM bracket, Measure from Top of Slotted Hole Up 1.5". Mark a straight cut line parallel to slotted hole on bracket. (See Photo # 27)

On Rearward Outer Edge of OEM bracket, Measure from Top of Slotted Hole Up 2.75". Mark a straight cut line parallel to slotted hole on bracket. (See Photo # 28)

On Inside Edge of OEM bracket, mark a cut line using Rearward Outer Edge across top of bracket. (See Photo # 29)

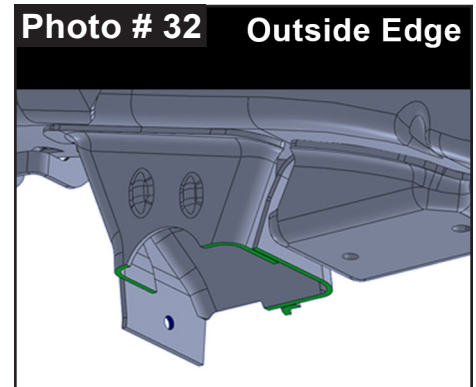
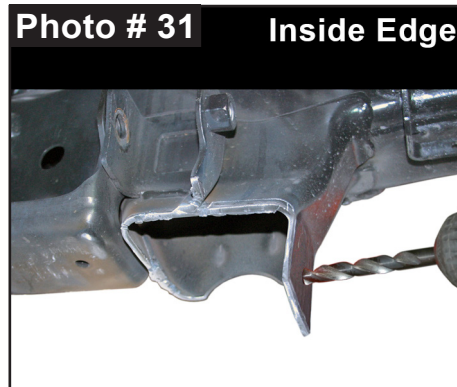
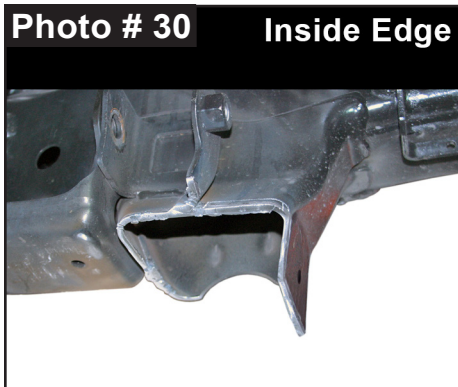
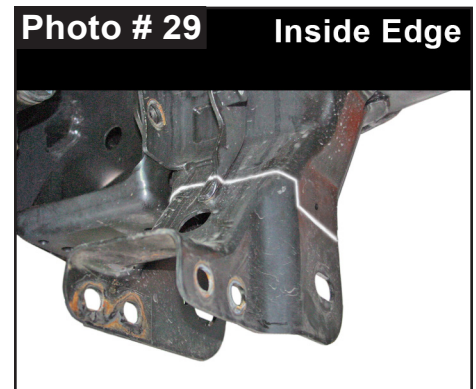
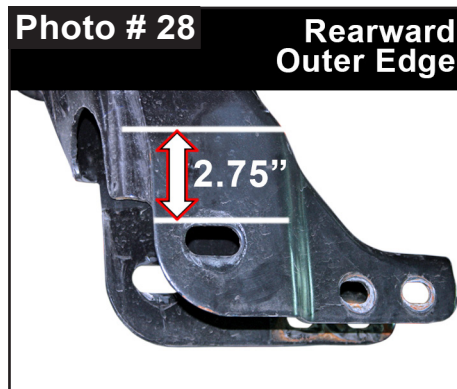
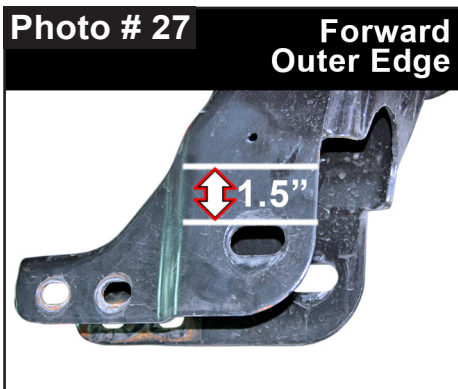
Mark a cut line from Forward Outer Edge Up to Inside Edge. (See Photo # 29)

Use a suitable Cut Off Tool, Sawzall Reciprocating Saw, etc to cut along marked edges. (See Photo # 30)

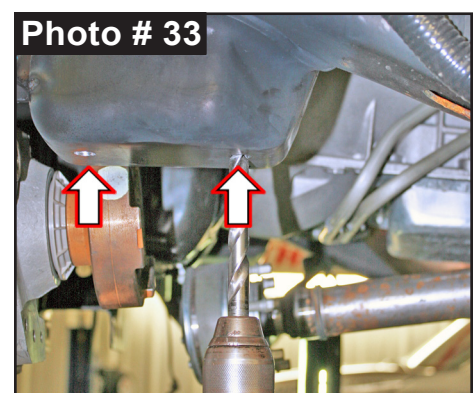
On Forward Side of OEM bracket, drill out factory hole using a drill & 13/32" drill bit. (See Photo # 31)

Refer to 3D Cad model for an example of what OEM brackets will look like once cut & drilled. (See Photo # 32)

**Note:** File smooth any burrs or sharp edges on OEM bracket, then paint or undercoat all exposed metal.



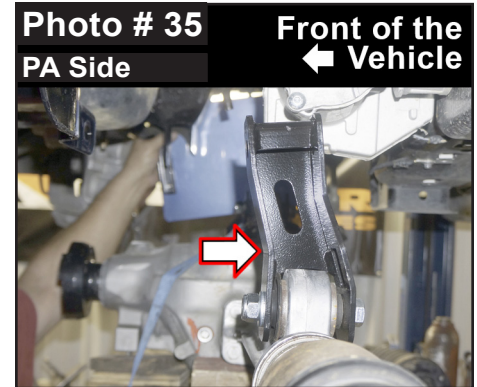
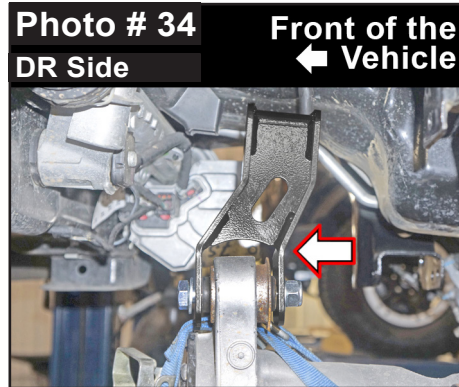
29. On driver side frame, drill out two (2) OEM Sway Bar Mounting Bracket Holes using a drill & 1/2" drill bit. (See Photo # 33)



30. Support OEM differential with a jack. Install Skyjacker Front Differential Brackets in OEM locations onto differential. **Note:** Skyjacker brackets are Side Specific: Part number is on silver bar code label. # F2160DDB-B Driver & # F2160PDB-B Passenger. (See Photos # 34 & # 35) **Tech Note:** Install with offset of differential brackets facing toward front of vehicle.

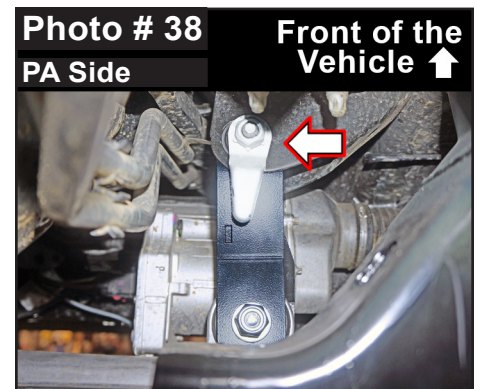
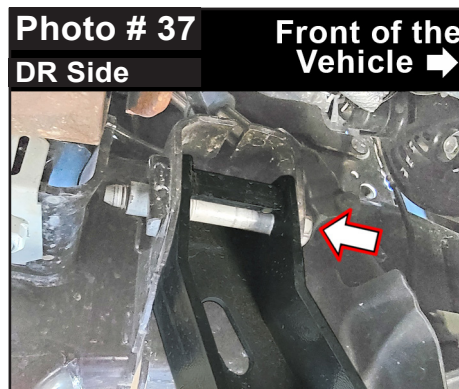
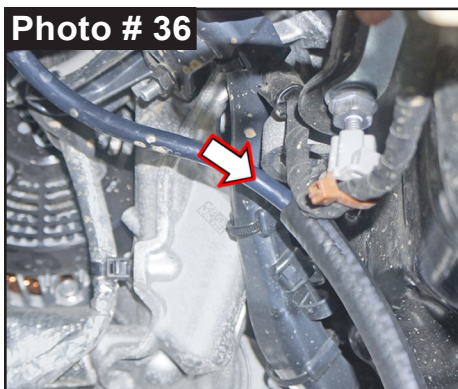
Install using supplied 14mm x 90mm Bolt with 9/16" SAE Washer on front side & a 14mm Nylon Insert Nut on back side in lower mounting location of Skyjacker Driver & Passenger Front Differential Brackets using a 21mm & a 22mm socket \ wrench.

**Note:** Supplied 9/16" SAE Washers are to be installed on hex head side of supplied 14mm x 90mm bolts. Secure, but **Do Not Completely Tighten** at this time.

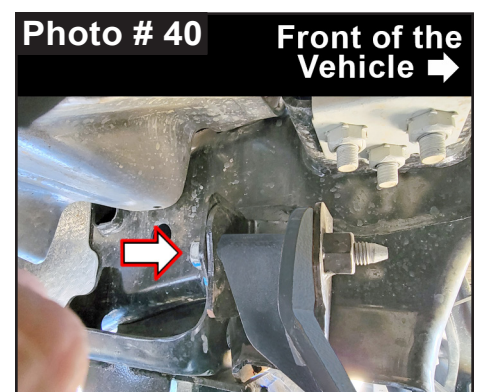
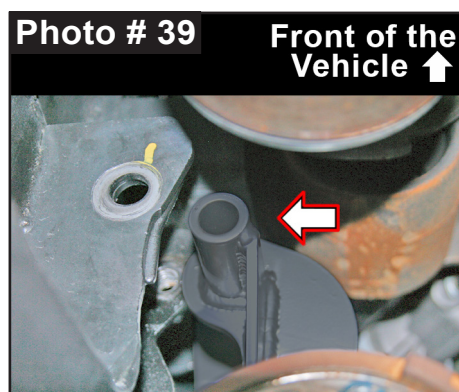


31. Install supplied Skyjacker # VH51610 Vent Hose to differential mount, then to upper hard vent line. (See Photo # 36)

Connect Skyjacker front upper differential mounting brackets to OEM mounts. (See Photos # 37 & # 38) Install using OEM hardware, a 18mm & a 21mm socket \ wrench.



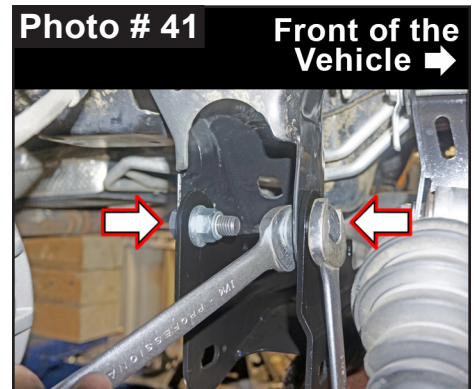
32. Install Skyjacker # F960DRB-B Driver Rear Differential Bracket in OEM location with flat side of Skyjacker bracket facing toward front of vehicle. (See Photo # 39 & # 40) Use OEM hardware & a 21mm socket \ wrench. Secure, but **Do Not Completely Tighten** at this time.



33. Install Skyjacker # F1546RCM-B Rear Crossmember, with driver side integrated sway bar lowering bracket facing toward rear of vehicle. **Note:** Bolts install from outside with Nylon Insert Nut attached on inside of OEM mount.

In Passenger side upper two (2) holes, install supplied 18mm x 50mm Bolt with 3/4" SAE Washer on outside & a 3/4" SAE Washer & a 18mm Nylon Insert Nut on inside using a 27mm socket \ wrench. (See Photo # 41)

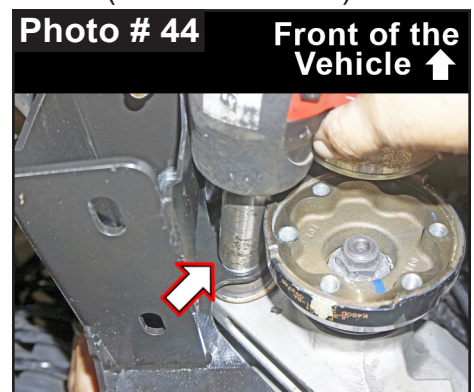
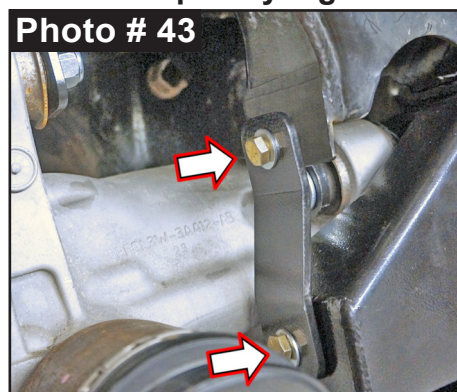
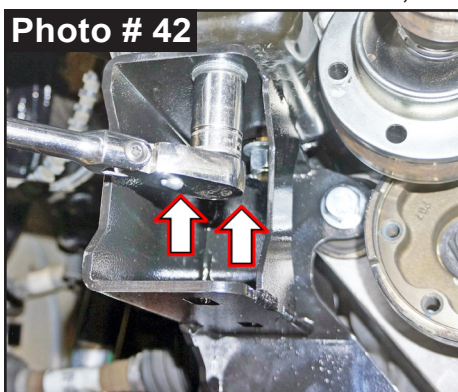
Secure, but **Do Not Completely Tighten** at this time.



34. Install Skyjacker Crossmember Integrated Sway Bar Lowering Bracket into two (2) drilled out holes with supplied 1/2" x 1-1/2" Bolt with 1/2" SAE Washer on bottom & a 1/2" SAE Washer with a 1/2" Nylon Insert Nut on top using a 3/4" socket \ wrench. Secure, but **Do Not Completely Tighten** at this time. (See Photo # 42)

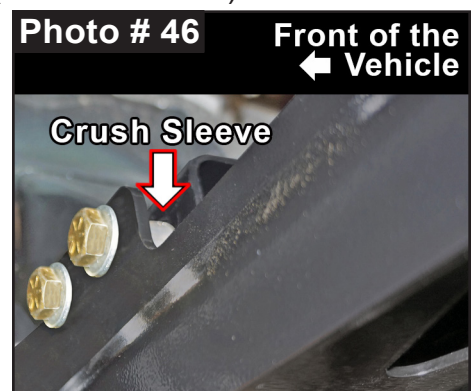
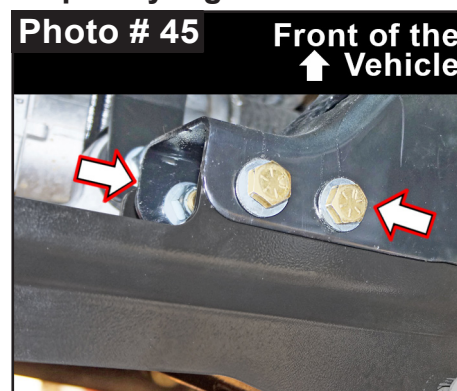
35. Install Skyjacker # F1546RCM-8 Rear Crossmember Brace into front hole of driver side OEM rear crossmember mount that was cut & drilled & into Skyjacker Rear Crossmember hole. Use supplied 3/8" x 1-1/4" Bolt with a 3/8" SAE Washer on front side & a 3/8" SAE Washer with a 3/8" Nylon Insert Nut on back side using a 9/16" socket \ wrench. (See Photo # 43)

36. Install supplied 14mm x 90mm Bolt & 14mm Nylon Insert Nut into lower mount hole of Skyjacker Driver Rear Differential Bracket & Rear Crossmember using a 21mm & a 22mm socket \ wrench. Secure, but **Do Not Completely Tighten** at this time. (See Photo # 44)

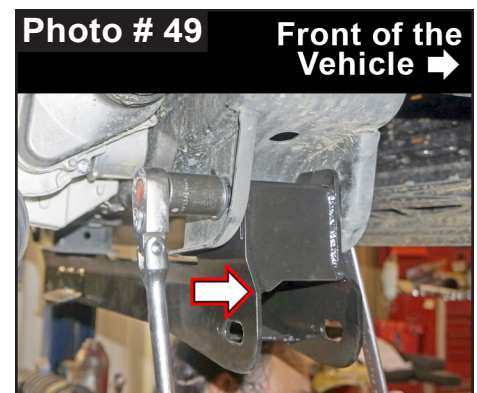
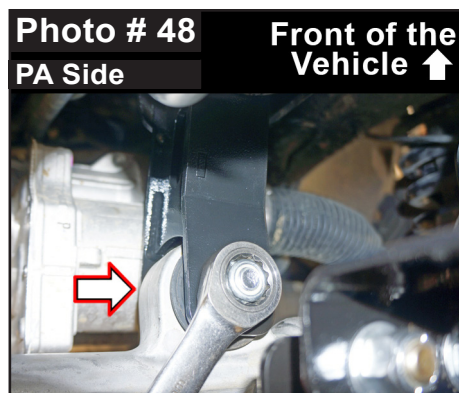
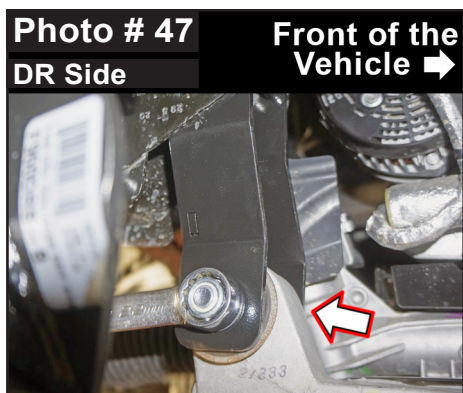


37. On Passenger side, attach two (2) rear holes of Skyjacker Rear Crossmember to OEM rear crossmember mount bracket by installing supplied 1/2" x 1-1/2" Bolts with a 1/2" SAE Washer on outside & a 1/2" SAE Washer with 1/2" Nylon Insert Nut on inside using a 3/4" socket \ wrench. Secure, but **Do Not Completely Tighten** at this time. (See Photo # 45)

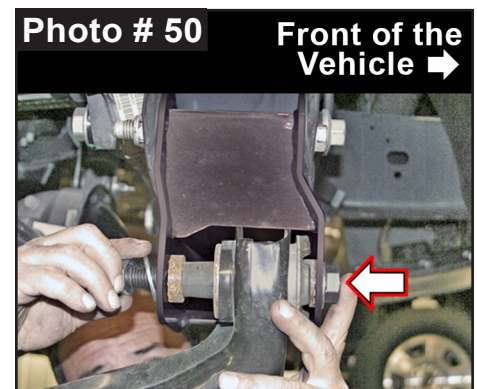
38. On Passenger side, attach two (2) front holes of Skyjacker Rear Crossmember to OEM rear crossmember mount bracket by installing supplied 1/2" x 2-1/4" Bolts with 1/2" SAE Washer on outside, # CS8125 13/16" Long Crush Sleeves in between & 1/2" SAE Washer with 1/2" Nylon Insert Nut on inside using a 3/4" socket \ wrench. (See Photo # 46) Secure, but **Do Not Completely Tighten** at this time.



39. Tighten 1/2" x 1-1/2" Bolts & 1/2" Nylon Insert Nuts located on Skyjacker Integrated Sway Bar Lowering Bracket using a 3/4" socket \wrench. (See Photo # 42) Torque to 90 ft-lbs.
40. Tighten 18mm x 50mm Bolts & 18mm Nylon Insert Nuts in Passenger Side Upper Rear Crossmember using a 27mm socket \wrench. (See Photo # 41) Torque to 240 ft-lbs.
41. Tighten 1/2" x 1-1/2" Bolts, 1/2" x 2-1/4" Bolts & 1/2" Nylon Insert Nuts of front & rear passenger side OEM crossmember bracket & Skyjacker crossmember using a 3/4" socket \wrench. (See Photos # 45 & # 46) Torque to 90 ft-lbs.
42. Tighten OEM hardware at upper mount of Skyjacker Driver Side Rear Differential Bracket using a 21mm socket / wrench. (See Photo # 40) Torque to 120 ft-lbs.  
Tighten 14mm x 90mm Bolt & 14mm Nylon Insert Nut at lower mount of Skyjacker Driver Side Rear Differential Bracket & Rear Crossmember using a 21mm socket \wrench & a 22mm socket \wrench. (See Photo # 44) Torque to 120 ft-lbs.
43. Tighten OEM hardware at upper mounts of Skyjacker Driver & Passenger Side Front Differential Brackets using a 18mm & a 21mm socket \wrench. (See Photo # 37 & # 38) Torque to 75 ft-lbs.  
Tighten 14mm x 90mm Bolt & 14mm Nylon Insert Nut at lower mounts of Skyjacker Driver & Passenger Side Front Differential Brackets using a 21mm & a 22mm socket \wrench. (See Photo # 47 & # 48) Torque to 120 ft-lbs.
44. Install Skyjacker # F1546FCM-B Front Crossmember with off-set facing toward front of vehicle. Install in upper two (2) holes of Skyjacker Crossmember using supplied 18mm x 150mm Bolt with a 3/4" SAE Washer on front side & a 3/4" SAE Washer with 18mm Nylon Insert Nut on back side using a 21mm & a 27mm socket \wrench. (See Photo # 49) Torque to 240 ft-lbs.



45. Install OEM lower control arms into Skyjacker front & rear crossmember lower mounts with OEM hardware using a 21mm & a 27mm socket \wrench. (See Photo # 50)  
**Note:** Insert front crossmember bolt in from front-to-rear. Insert rear crossmember bolt in from rear-to-front.



**Note:** Perform Steps 46-64 on One Side at a Time. Complete Steps on One Side, THEN Go to Opposite Side & Repeat Same Steps.

46. Assemble Skyjacker Strut Spacer using supplied 10mm x 30mm Carriage Bolts & 10mm Push Nuts. (See Photo # 51)

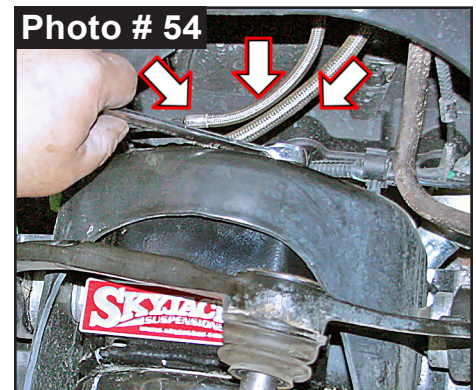
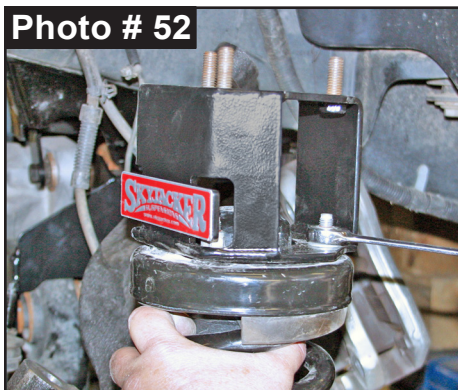
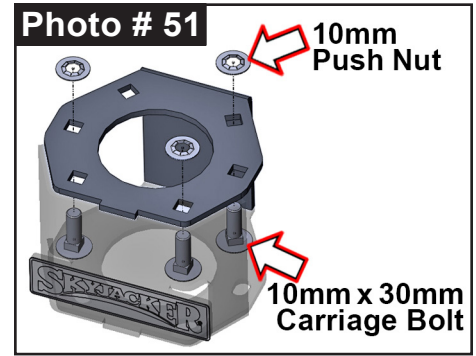
**Note:** Skyjacker Strut Spacers are not side specific. They are lift height specific # F945MS-S 4.5 Inch or # F960MS-S 6 Inch.

47. Install Skyjacker Strut Spacers on top of OEM strut assembly using OEM hardware & a 15mm socket \ wrench. (See Photo # 52) Secure, but **Do Not Completely Tighten** at this time.

48. Install Skyjacker \ OEM strut assembly into upper strut mount at frame. Align three (3) studs of strut spacer with OEM mount. For proper strut alignment purposes, mark location of upper strut mount & Skyjacker strut spacer. (See Photo # 53)

49. Remove Skyjacker \ OEM strut assembly. Align with previously made marks & tighten Skyjacker Spacer to OEM strut assembly using a 15mm socket \ wrench. Torque to 45 ft-lbs.

50. Install Skyjacker \ OEM strut assembly into upper strut mount at frame using supplied 10mm nuts & a 15mm socket \ wrench. (See Photo # 54) Torque to 45 ft-lbs.

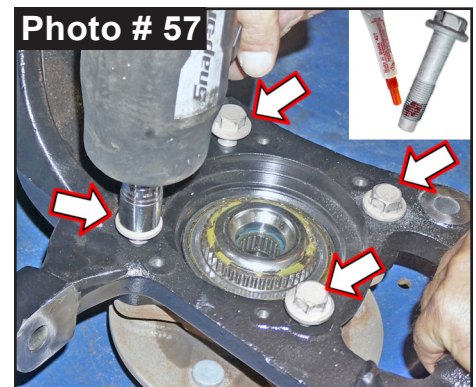
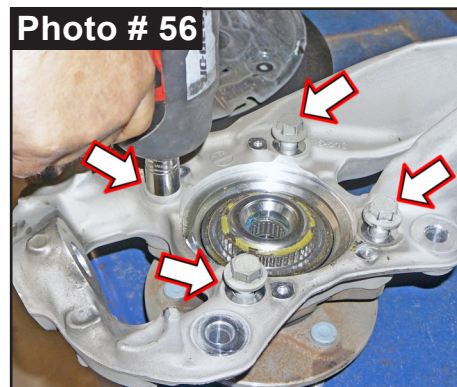
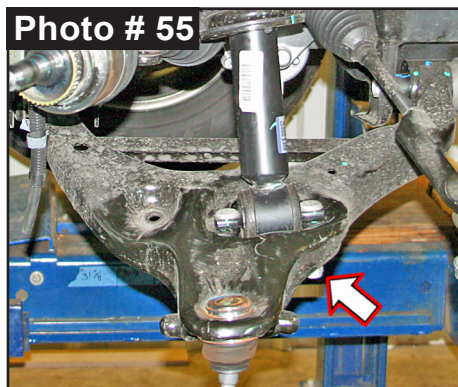


51. Install Skyjacker \ OEM strut assembly into lower control arm mount using factory hardware & a 18mm socket \ wrench. (See Photo # 55) Torque to 75 ft-lbs.

52. Transfer hub bearing assembly from OEM knuckle to Skyjacker Knuckle. **Note:** Skyjacker Knuckles are side specific. # F2146L Driver & # F2146R Passenger.

Remove four (4) OEM hub bearing bolts using a 18mm socket \ wrench. (See Photo # 56)

Apply supplied Thread Lock Compound to four (4) OEM hub bearing bolts. Install OEM hub bearing assembly to Skyjacker Knuckle using four (4) OEM hub bearing bolts & a 18mm socket \ wrench. (See Photo # 57) Torque to 145 ft-lbs.



53. Connect Skyjacker Knuckle to OEM lower control arm ball joint using OEM hardware & a 21mm socket \ wrench. (See Photo # 58) Secure, but **Do Not Completely Tighten** at this time.

Install OEM 4WD actuator assembly to Skyjacker Knuckle using three (3) OEM 4WD actuator bolts & a 8mm socket \ wrench. (See Photo # 58)

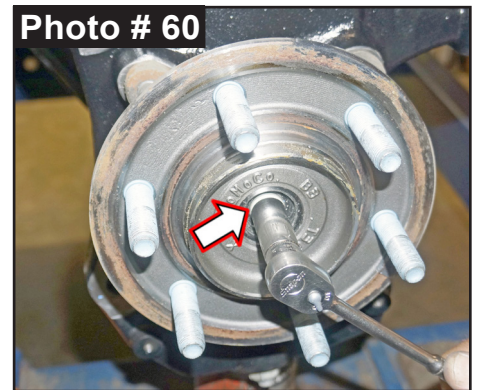
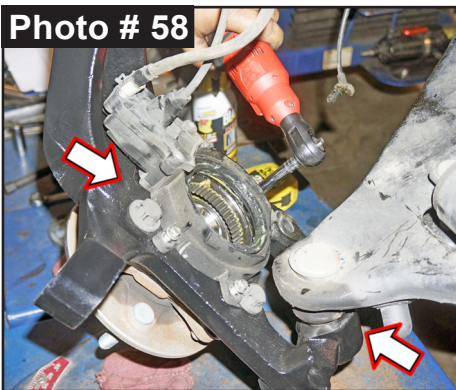
54. Connect OEM upper ball joint to Skyjacker Knuckle using an 8mm wrench & a 21mm wrench. (See Photo # 59) **CAUTION:** Do Not Use an impact to tighten. Use hand tools.

**Note:** While connecting upper ball joint, be sure CV shaft properly aligns into 4WD actuator.

**Tech Note:** It may be necessary to use a jack to raise OEM lower control arm in order to install OEM upper ball joint and/or a pry bar to lower OEM upper control arm.

55. Install OEM CV-shaft using OEM axle nut & a 13mm socket \ wrench. Torque 30 ft-lbs.

**CAUTION:** Do Not Use an impact to tighten. Do not damage CV shaft or threads. (See Photo # 60) Install OEM CV shaft dust cover to center of OEM hub assembly with a rubber mallet.



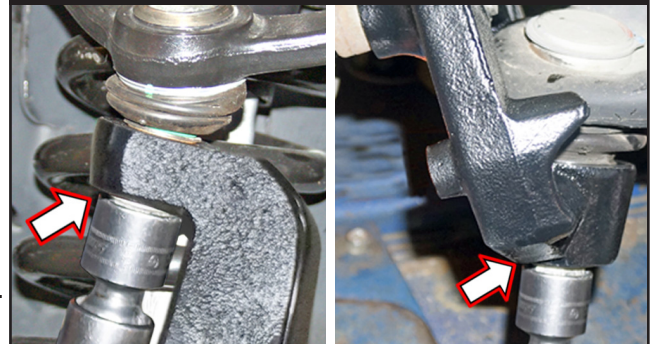
56. Tighten upper ball joint nut using a 21mm socket \ wrench. Torque 46 ft-lbs. (See Photo # 61)

Tighten lower ball joint nut using a 21mm socket \ wrench. Torque 76 ft-lbs. (See Photo # 61)

**CAUTION:** Do Not Use an impact to tighten. Use hand tools.

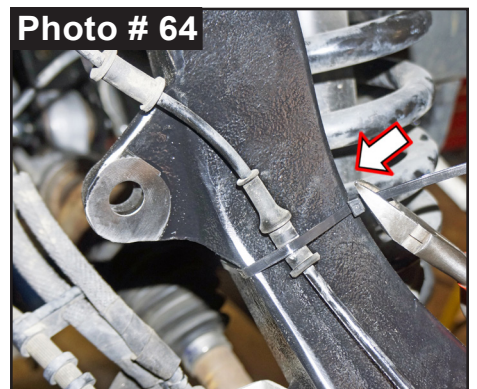
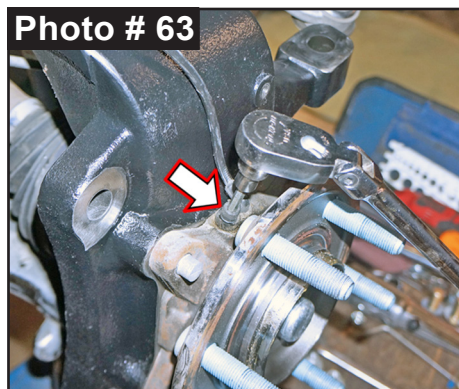
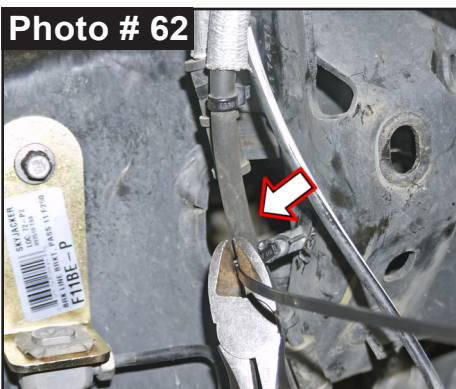
57. Follow ABS sensor line up to frame. Connect ABS line to OEM tie clip using supplied plastic cable tie. (See Photo # 62)

**Photo # 61**



58. Connect ABS sensor bracket to outward side of Skyjacker knuckle using OEM hardware & a 5mm hex key wrench. (See Photo # 63) Torque 96 in-lbs.

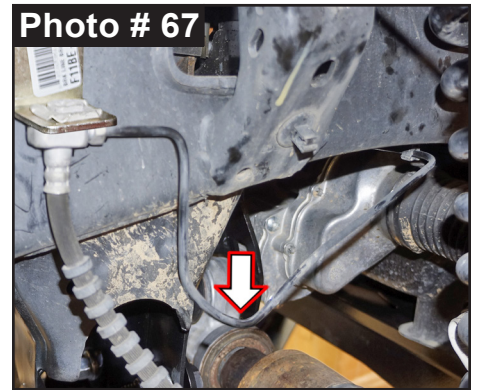
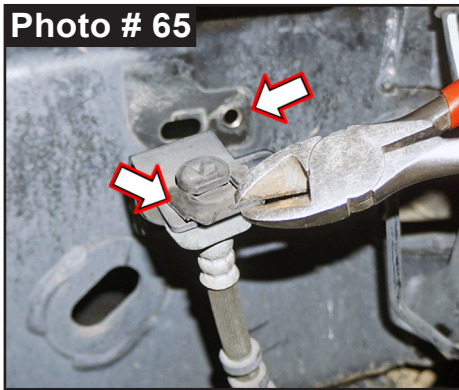
59. Secure ABS sensor line to Skyjacker knuckle using supplied plastic cable tie. (See Photo # 64)



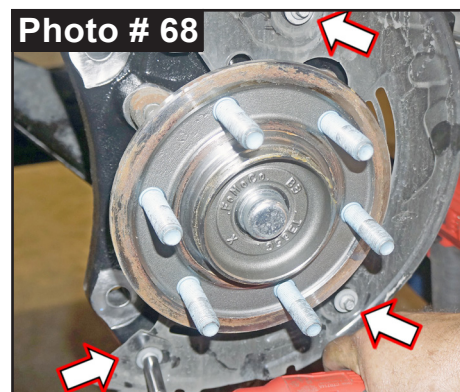
60. Disconnect OEM front brake line bracket from frame using a 10mm socket \wrench. Remove OEM front brake line retaining clip from OEM bracket using pliers. (See Photo # 65) Remove brake line from OEM bracket.

**Note:** Skyjacker Brackets are Side Specific: # F11BE-D Driver & # F11BE-P Passenger. Connect OEM brake line to Skyjacker Bracket using OEM brake line retaining clip. Install Skyjacker Front Brake Line Bracket into OEM position on frame using OEM bolt & a 10mm socket \wrench. (See Photo # 66) Torque to 60 in-lbs.

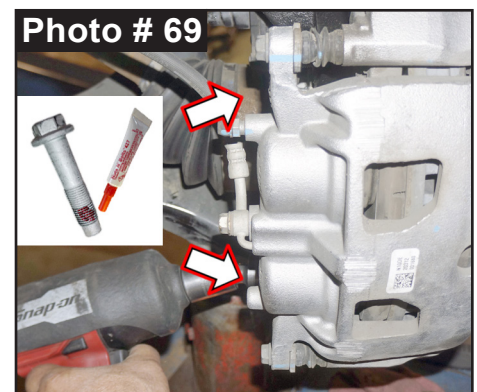
**CAUTION:** Observe OEM brake line curvature & closeness to CV axle. (See Photo # 67) If necessary, straighten brake line tubing to a more rounded curve using tube bending pliers \ tube straightener pliers. Avoid kinking any of brake line. Check clearance near CV axle.



61. Install OEM disc brake shield using three (3) OEM bolts & a 8mm socket \wrench. (See Photo # 68) Torque 168 in-lbs.



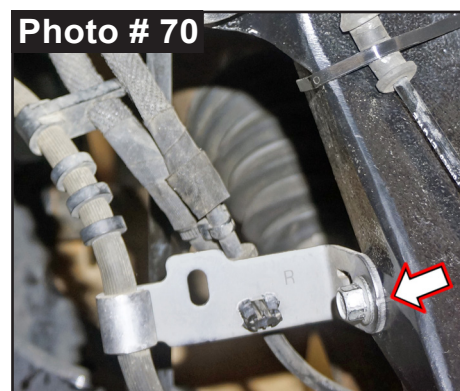
62. Connect brake rotor onto Skyjacker knuckle \hub assembly. **Tech Note:** Use a factory lug nut to temporarily secure rotor into place.



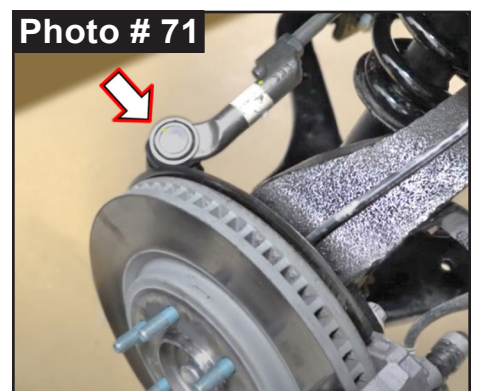
Apply supplied Thread Lock Compound to OEM brake caliper bolts.

Connect OEM brake caliper onto rotor & Skyjacker knuckle \hub assembly using a 21mm socket \wrench. (See Photo # 69) Torque 184 ft-lbs.

63. Connect OEM brake line bracket to rearward side of OEM knuckle using OEM bolt & a 10mm socket \wrench. (See Photo # 70)

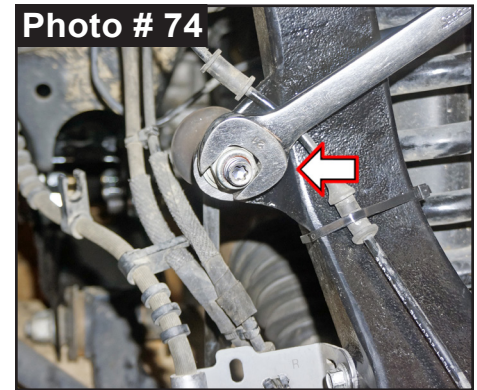
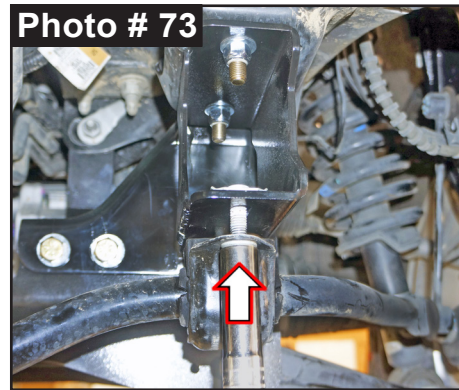
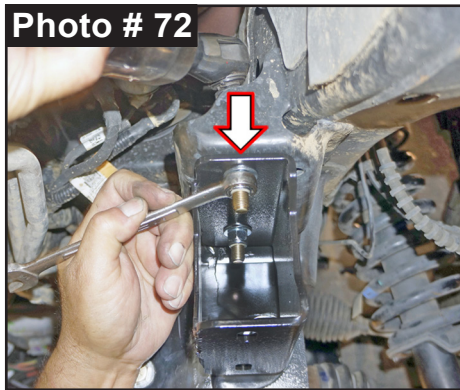


64. Connect OEM outer tie rod end to Skyjacker steering knuckle from top-down using OEM hardware & a 21mm socket \wrench. (See Photo # 71) Torque 76 ft-lbs. **Tech Note:** Make sure tie rod end jam nut is tight.

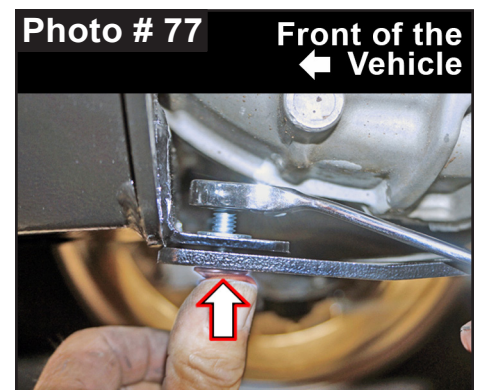
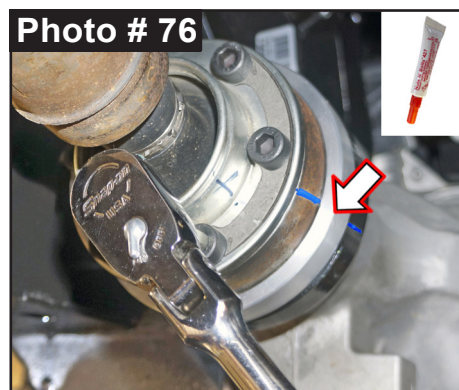
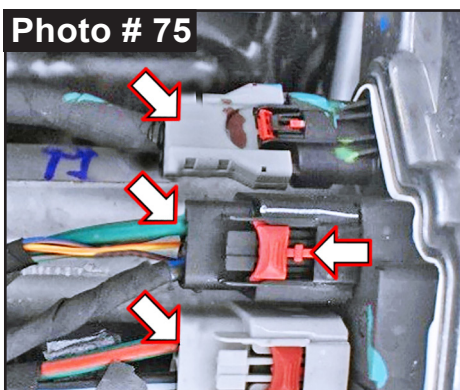


**Note:** Perform Steps 46-64 on Opposite Side at this Time.

65. Install Skyjacker # F1546SBL-P Sway Bar Drop Bracket on Passenger Side frame using supplied 7/16" x 1-1/2" Bolt with 7/16" SAE Washer from down top & a 7/16" SAE Washer with a 7/16" Nylon Insert Nut from bottom using a 5/8" socket \ wrench. (See Photo # 72) Torque to 45 ft-lbs.
66. Connect OEM sway bar \ brackets to Skyjacker Sway Bar Lowering Brackets using OEM sway bar stud plates & nuts with a 15mm socket \ wrench. (See Photo # 73) Torque to 35 ft-lbs.
67. Connect OEM sway bar end links to OEM lower control arms using OEM hardware & a 21mm socket \ wrench. (See Photo # 74) Secure, but **Do Not Completely Tighten** at this time.



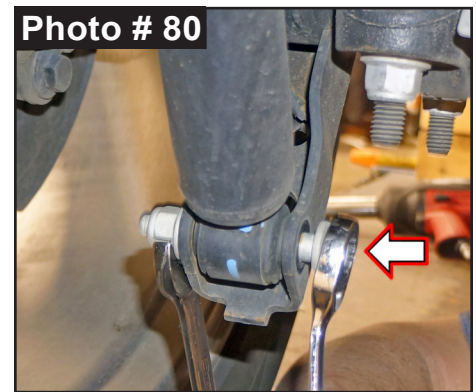
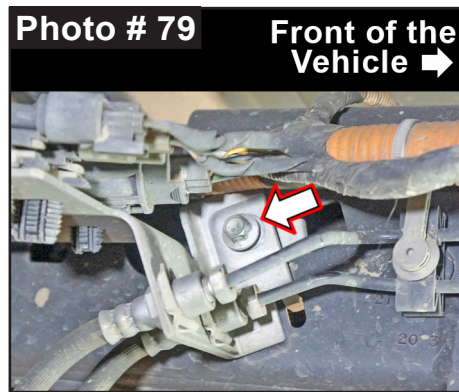
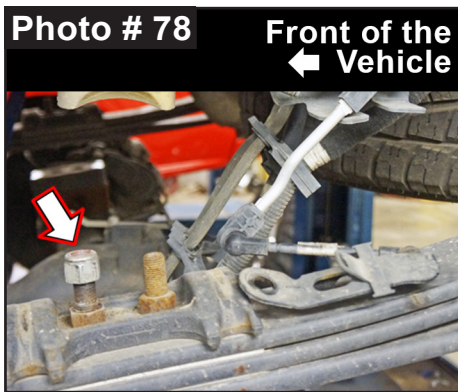
68. Connect three (3) EPAS plugs on steering assembly. (See Photo # 75) **Tech Note:** Press & hold rearward black tang down, grab connector & push plug-in. Push red slide into lock position. **Note:** Pull out on connector to verify that it is securely plugged in properly.
69. Apply supplied Thread Lock Compound to supplied 10mm x 80mm Socket Head Bolts. Install Skyjacker # F960DSS-S Front Drive Shaft Spacer with male side facing differential using supplied 10mm x 80mm Socket Head Bolts, OEM retaining rings, & a 8mm hex key. **Note:** Be sure to align previously made marks on OEM front differential flange & OEM drive shaft flange. (See Photo # 76) Torque to 41 ft-lbs.
70. Install Skyjacker # F1546SKD-S Front Differential Skid Plate to Skyjacker Front & Rear Crossmembers. Attach using supplied four (4) 5/16" x 1" carriage bolts up through skid plate with 5/16" SAE Washers & 5/16" Nylon Insert Nuts on top of crossmember mounts using a 1/2" socket \ wrench. (See Photo # 77) Torque to 180 in-lbs.



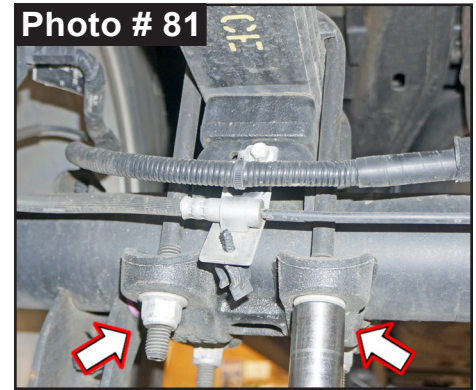
71. Install front tires \ wheels using a 21mm socket & lower front of vehicle to ground. Torque to OEM service manual specifications.

**Rear Installation: Note: Save all factory components & hardware for reuse, unless noted.**

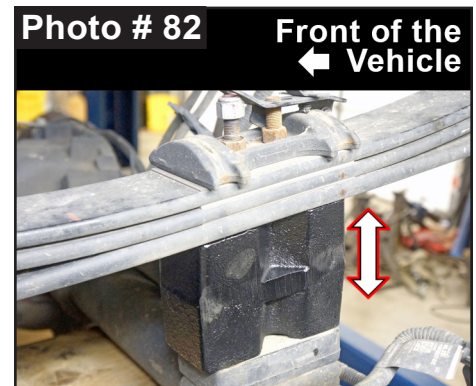
1. Chock front tires \ wheels. Raise rear of vehicle & support frame rails using jack stands at indicated lift points in OEM service manual.
2. Remove rear tires \ wheels using a 21mm socket.
3. If equipped with Adaptive Headlights, disconnect level sensor from upper leaf spring mount on driver side. Remove forward OEM nut using a 19mm socket \ wrench. Set lever mount rearward out of way. (See Photo # 78)
4. On driver side inner frame rail near rear bump stop mount, locate OEM rear brake line connection where hard brake lines connect to brake hoses. Disconnect OEM rear brake line bracket from frame rail using a 10mm socket \ wrench. (See Photo # 79)
5. Support rear axle with a hydraulic jack. Allow ample room to lower rear axle.
6. Remove OEM rear shocks a 15mm & a 18mm socket \ wrench. (See Photo # 80)



7. Remove OEM u-bolts using a 21mm socket \ wrench. Discard u-bolts & hardware. Retain lower OEM u-bolt plate. (See Photo # 81)
8. **4.5" Lift:** While checking for appropriate slack in ABS lines, brake lines, differential breather hose, & etc, lower rear axle & remove OEM rear blocks. Clean spring pads of all debris. Remove OEM block. Position Skyjacker # RB452 Dual Pin 4.5" Rear Lift Block on top of axle pad. **Note:** Place taller end of lift block toward rear of vehicle. (See Photo # 82)

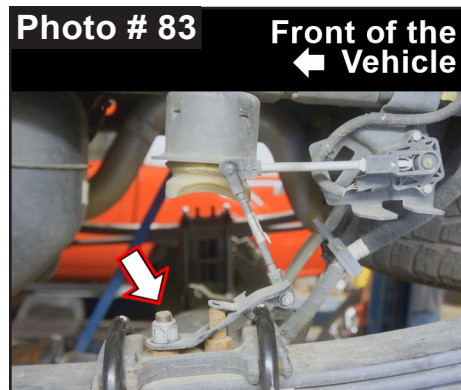


- 6" Lift:** While checking for appropriate slack in ABS lines, brake lines, differential breather hose, & etc, lower rear axle. Clean spring pads of all debris. Position Skyjacker # RB452 Dual Pin 4.5" Rear Lift Block On Top of OEM block & axle pad. **Note:** Place taller end of lift block toward rear of vehicle. (See Photo # 82)



9. Raise axle to mate leaf springs to lift blocks. **Note:** Be sure that leaf spring center bolts heads seat properly into block & that block pin seats properly into top of axle pad \ OEM block on 6 inch). (See Photo # 82)

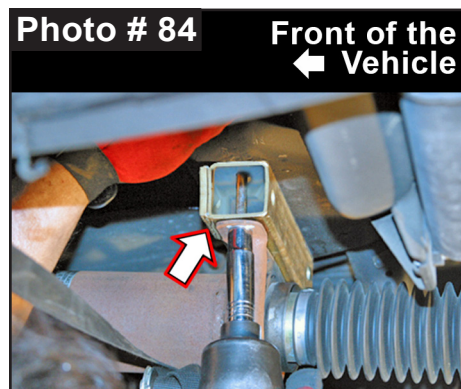
10. Install Skyjacker 9/16" u-bolts over leaf springs \ top plate down into OEM u-bolt plate. Install supplied 9/16" Nylon Insert Nuts using a 7/8" socket \ wrench. Tighten u-bolts evenly using an 'X' crisscross tightening sequence.
11. If equipped with Adaptive Headlights, connect level sensor to upper leaf spring mount on driver side. Attach forward OEM nut using a 19mm socket \ wrench. (See Photo # 83)  
Torque to 35 ft-lbs.



12. **Note:** On models equipped with a carrier bearing on rear driveshaft, it will be necessary to install supplied Skyjacker # CBL255-B Carrier Bearing Lowering Bracket to help eliminate any driveline vibration. Bracket will mount between OEM carrier bearing & OEM mount.

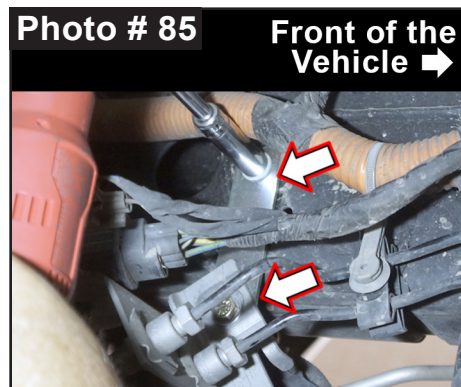
Support driveshaft, remove bolts from OEM carrier bearing bracket using a 17mm socket \ wrench. Install Skyjacker Bracket between OEM bearing bracket & OEM mount.

**Note:** Install bracket with flat part on OEM mount & taper part toward front. Install with supplied 10mm x 90mm Bolt with 3/8" SAE Washer & a 17mm socket \ wrench. (See Photo # 84)  
Torque to 45 ft-lbs.



13. On driver side inner frame rail near rear bump stop mount, install Skyjacker # DVL10 Rear Brake Line Bracket into OEM position using OEM hardware & a 10mm socket \ wrench.

Connect OEM brake line bracket to Skyjacker Bracket using supplied 1/4" x 1" Bolt with 1/4" SAE Washer on outside & a 1/4" SAE Washer with a 1/4" Nylon Insert Nut on inside using a 7/16" socket \ wrench. (See Photo # 85)  
Torque to 180 in-lbs.

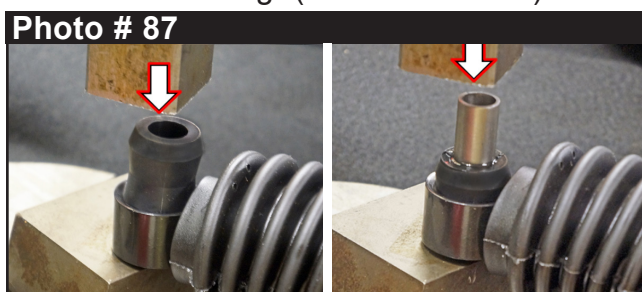
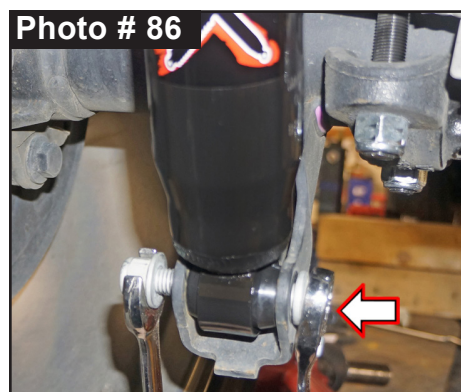


**NOTE: Kit With HYDRO, NITRO, Black MAX, or M95 Monotube:**  
Proceed to Step 14.

**Kit With ADX 2.0 Remote Reservoir:** Proceed to Step 15.

14. Install Skyjacker rear shock. Connect upper shock mount with OEM hardware using a 18mm socket \ wrench.  
Connect lower shock mount with OEM hardware using an 18mm & a 21mm socket \ wrench. (See Photo # 86)  
Secure, but **Do Not Completely Tighten** at this time.

**Tech Note:** To install shock bushing & sleeves, spray a light coat of silicone spray onto bushing. Press bushing into shock mount. Spray a light coat of silicone spray onto sleeve. Press sleeve into shock bushing. (See Photo # 87)



15. Locate Skyjacker ADX rear shock. Loosely assemble two (2) supplied reservoir clamps with two (2) supplied hex head bolts using a 5/32" Hex Key socket. Position clamp into place around shock body & reservoir cylinder. Secure, but **Do Not Completely Tighten** at this time.  
Install Skyjacker ADX rear shock. Connect upper shock mount with OEM hardware using a 18mm socket \ wrench. Connect lower shock mount with OEM hardware using an 18mm & a 21mm socket \ wrench. Secure, but **Do Not Completely Tighten** at this time.  
**CAUTION:** Make Sure ADX Shock Reservoir \ Reservoir Hose Does Not & Will Not Make Contact with Anything Throughout the Full Travel Cycle of the Suspension. (frame, sway bar, springs, brake lines, exhaust, etc.) For proper clearance, it may be necessary to change the location or orientation of the reservoir on the shock body. Use a 5/32" Hex Key socket to loosen clamps to position reservoir cylinder as needed.
16. Install rear tires \ wheels using a 21mm socket & lower rear of vehicle to ground. Torque to OEM service manual specifications.
17. Torque u-bolts evenly using an 'X' crisscross tightening sequence. Torque to 110 ft-lbs.

### **Final Front Steps:**

1. Start vehicle. Make sure there are no dash lights pertaining to suspension.
2. Jounce vehicle a couple of times. This will help suspension settle to new ride height. Cycle steering lock-to-lock & check all components for proper operation & clearances. Pay special attention to clearance between tires \ wheels, ADX Shocks & Reservoirs, control arms, brake hoses, ABS wiring, etc.
3. **Front Tighten & Torque Sequence.**  
Front OEM lower control arms using a 21mm & a 27mm socket \ wrench. Torque 220 ft-lbs.  
Front OEM upper control arms using a 18mm socket \ wrench. Torque 100 ft-lbs.  
If equipped, connect OEM ball link to driver side OEM upper control arm using a 8mm wrench & 11mm wrench.  
Front OEM sway bar end link to OEM knuckle using a 21mm socket \ wrench. Torque 65 ft-lbs.
4. **Rear Tighten & Torque Sequence.**  
Rear shock absorber upper mount using a 18mm socket \ wrench. Torque 65 ft-lbs.  
Rear shock absorber lower mount using a 18mm & a 21mm socket \ wrench. Torque 65 ft-lbs.  
ADX Reservoir clamp. Double check position & clearance. Tighten with 5/32" Hex Key socket.  
Torque u-bolts evenly using an 'X' crisscross tightening sequence. Torque 132 ft.-lbs.

## **Final Notes:**

- After installation is complete, double check that all nuts & bolts are tight. Refer to following chart for proper torque specifications. (**Note:** Do not re-tighten nuts & bolts where thread lock compound was used.)
- With vehicle placed on ground, cycle steering lock to lock & inspect steering, suspension, brake lines, front & rear drivelines, fuel lines & wiring harnesses for proper operation, tightness & adequate clearance.
- Have headlights readjusted to proper settings.
- Have a qualified alignment center align vehicle to OEM specifications.
- After first 100 miles, check all hardware for proper torque & periodically thereafter.

<b>TORQUE SPECIFICATIONS</b>					
<b>INCH SYSTEM</b>			<b>METRIC SYSTEM</b>		
<b>Bolt Size</b>	<b>Grade 5</b>	<b>Grade 8</b>	<b>Bolt Size</b>	<b>Class 8.8</b>	<b>Class 10.9</b>
5/16	180 in-lbs	240 in-lbs	6MM	60 in-lbs	108 in-lbs
3/8	30 ft-lbs	35 ft-lbs	8MM	216 in-lbs	23 ft-lbs
7/16	45 ft-lbs	60 ft-lbs	10MM	32 ft-lbs	45 ft-lbs
1/2	65 ft-lbs	90 ft-lbs	12MM	55 ft-lbs	75 ft-lbs
9/16	95 ft-lbs	130 ft-lbs	14MM	85 ft-lbs	120 ft-lbs
5/8	135 ft-lbs	175 ft-lbs	16MM	130 ft-lbs	165 ft-lbs
3/4	185 ft-lbs	280 ft-lbs	18MM	170 ft-lbs	240 ft-lbs
<b>The Above Specifications Are Not to Be Used When the Bolt Is Being Installed With a Bushing.</b>					

**Seat Belts Save Lives. Please Wear Your Seat Belt.**



**JESUS  
FORGIVES  
ROCKS  
DON'T**

***Jesus Christ Died For You.***

John 3:16

For God so loved the world that He gave His only Son, so that everyone who believes in Him should not perish, but have everlasting life.  
Romans 3:23

For all have sinned; all fall short of God's glorious standard.  
Ephesians 2:8

God saved you by his special favor when you believed. And you can't take credit for this; it is a gift from God.  
Psalms 18:2

The Lord is my Rock, my fortress, and my savior; my God is my Rock, in whom I find protection. He is my shield, the strength of my salvation, and my stronghold.  
Romans 10:9-10

That if you shall confess with thy mouth the Lord Jesus, and shall believe in your heart that God hath raised him from the dead, you shall be saved. For with the heart man believeth unto righteousness; and with the mouth confession is made unto salvation.

**Pray This Simple Prayer:**

God, I come to You admitting I have sinned against You and I need you to take control of my life. The Bible says anyone who calls on the name of the Lord will be saved. I am calling on You, Jesus. I ask that You come live in my heart and be the Lord over my life today. I do believe You died on the cross for me and came back to life to give me life! Thank You, Lord Jesus for a new life in You!

Now, go and tell somebody about your new life in Jesus, get a Bible, begin to read it, and go to a Bible believing church.

If you would like someone to pray with you, call Kenneth Copeland Ministries anytime at 800-600-7395.

To listen to commercial free Christian radio on the web, go to [www.887fm.org](http://www.887fm.org)

***Jesús murió por ti.***

Juan 3:16

“Porque tanto amó Dios al mundo, que dio a su Hijo unigénito, para que todo el que cree en él no se pierda, sino que tenga vida eterna.”  
Romanos 3:23

“Pues todos han pecado y están privados de la gloria de Dios.”  
Efesios 2:8

“Porque por gracia ustedes han sido salvados mediante la fe; esto no procede de ustedes, sino que es el regalo de Dios.”  
Salmos 18:2

“El Señor es mi roca, mi amparo, mi libertador; es mi Dios, el peñasco en que me refugio. Es mi escudo, el poder que me salva, ¡mi más alto escondite!”  
Romanos 10:9-10

“9 Que si confi esas con tu boca que Jesús es el Señor, y crees en tu corazón que Dios lo levantó de entre los muertos, serás salvo. 10 Porque con el corazón se cree para ser justifi cado, pero con la boca se confi esa para ser salvo.”

**Ahora dí esta simple oración:**

Dios, vengo a Ti y admito que he pecado contra Ti, necesito que tomes el control de mi vida. La Biblia dice que todo aquel que invoca el nombre del Señor escapará con vida. En este momento yo clamo ante Ti, Jesús; te pido que vengas a vivir en mi corazón y que tomes el control de mi vida. ¡Yo creo que tu moriste en la cruz y resucitaste para darme vida! ¡Gracias Señor Jesús, por una nueva vida que tengo en Ti! Amen.

Ahora ve y dile a alguien sobre la nueva vida que tienes en Cristo. Compra una Biblia y empieza a leerla. Busca una Iglesia que cree en la Biblia y hazte parte de esa Iglesia.

Si te gustaría orar con alguien, puedes llamar a este número 800-600-7395

Puedes ir a este sitio de Internet para escuchar música Cristiana sin anuncios, [www.887fm.org](http://www.887fm.org)

**Check out our favorite ministries at:**



[www.innministries.org](http://www.innministries.org)  
[www.familychurch.org](http://www.familychurch.org)  
[www.kcm.org](http://www.kcm.org)