



2006-2007 Dodge 5.7L Hemi 4WD  
 1994-2001 Dodge Ram 1500 4WD  
 1994-2013 Dodge Ram 2500 4WD  
 2011-2013 Dodge Ram 3500 4WD  
 1994-2009 Dodge Ram 3500 4WD

## Installation Instructions

### Required Tools List:

- SAE Sockets \ Wrenches  
(1/4", 5/8", 13/16" & 1-1/16")
- Metric Sockets \ Wrenches  
(13mm, 14mm, 15mm, 21mm, 22mm, 24mm & 33mm)
- Diagonal Cutting Pliers
- Cut-Off Tool or Hacksaw
- Adjustable Locking Pliers
- Tie Rod Removal Tool
- Pitman Arm Puller Tool
- Large Flat Screwdriver
- Grease Gun
- C-Clamps
- Wheel Chock
- Jack Stands
- Torque Wrench
- Paint Marker
- Safety Glasses
- Floor Jack
- Measuring Tape



Before beginning installation, read these instructions & enclosed driver's WARNING NOTICE thoroughly & completely. Also affix WARNING decal in passenger compartment in clear view of all occupants. Please refer to Parts List to insure that all parts & hardware are received prior to disassembly of vehicle. If any parts are found to be missing, contact SKYJACKER® Customer Service at 318-388-0816 to obtain needed items. If you have any questions or reservations about installing this product, contact SKYJACKER® Technical Assistance at 318-388-0816.

**Please Record the Important Measurement Information Below for Reference.**

**It is very helpful on determining an Accurate Achieved Lift Height Measurement.**

Make sure you park vehicle on a level concrete or asphalt surface. Many times a vehicle is not level (side-to-side) from factory, but is usually not noticed until a lift kit has been installed which makes difference more visible. Using a measuring tape, measure front & rear (both sides) from ground up to center of fender opening above axle.

Driver Side Front: \_\_\_\_\_ / \_\_\_\_\_  
 BEFORE / AFTER

Passenger Side Front: \_\_\_\_\_ / \_\_\_\_\_  
 BEFORE / AFTER

Driver Side Rear: \_\_\_\_\_ / \_\_\_\_\_  
 BEFORE / AFTER

Passenger Side Rear: \_\_\_\_\_ / \_\_\_\_\_  
 BEFORE / AFTER

### Important Notes:

- Lift Kit Height is Based off of Front Lift Height with Less Rear Lift for a More Level Stance.
- If Larger Tires (10% More Than the OEM Diameter) Are Installed, Speedometer Recalibration Will Be Necessary. Contact Your Local RAM Dealer or an Authorized Skyjacker® Dealer for Details.
- After Installation, a Qualified Alignment Facility Is Required to Align the Vehicle to the OEM Specifications.
- On 3/4 Ton Models, It Is Recommended to Check GVWR Rating & Width of Rear Springs to Assure You Have the Correct Kit BEFORE Beginning Installation. If you have any questions or reservations, contact SKYJACKER® Technical Assistance at 318-388-0816.

- Check Coil Spring Part Number: Kits Beginning with **D30** & Include # **D30** Coil Springs Are for All 1/2 Ton & 3/4 Ton Models Up to 7,500 Pounds Gross Vehicle Weight Rating (GVWR) (*which have lighter rated front coil springs & 2-1/2" Wide Rear Springs*).
- Check Coil Spring Part Number: Kits Beginning with **D25** & Include # **D25** Coil Springs Are Designed for Heavy Duty 3/4 Ton & 1 Ton Models Equipped with V10 and Cummins Diesel Engines (*which have heavier rated front coil springs & 3" Wide Rear Springs*). If Equipped with a "Camper Package" or "Towing Package", Longer U-bolts May Be Necessary & Possibly Spring Spacers # SP1230.
- BEFORE Beginning Installation, Models with Rear Springs Consisting of an Overload Spacer & Overload Leaf on TOP of Rear Spring Pack, May Need Longer Rear U-bolts (*compare the u-bolts supplied in this kit to be sure they are at least 1-1/2" Longer Than Stock*). This Is Found on Models Equipped with a "Camper Package" or "Towing Package".
- Dually Models Will Receive Less Lift than Stated & Usually Have a "Camper Package" or "Towing Package", Which May Require Longer U-bolts & Possibly Spring Spacers # SP1230.
- Under NO Circumstances Are SKYJACKER® Coil Springs to Be Used in Conjunction with Any Type of Coil Spring or Spring Tower Block \ Spacer. The Use of Coil Spring Block \ Spacers Will Allow ANY Coil Spring to Exceed Its Designed Stress & Travel Loads Allowing It Be Overstressed, Over Sprung, Fatigued & Possibly Breakage. SKYJACKER® Warranty Is Void Under Any Such Application.

### Component Box Breakdown:

#### Part # D251

Item #	Description	Qty
R372S	DODGE RAM ADD-A-LEAF, SGL	2
1206	1/2 X 6 TIE BOLTS, PAIR W/NUTS	1
DLL23-L	LOWER LINK, DODGE RAM	2
BP40S	BUMP STOP, DODGE RAM	2
HB-LL175	HDWR BAG: LOWER LINK	1

#### Part # D251S

Item #	Description	Qty
916X318X812U	9/16 X 3-1/8 X 8-1/2 U-BOLT	4
DLL23-L	LOWER LINK, DODGE RAM	2
BP40S	BUMP STOP, DODGE RAM	2
HB-LL175	HDWR BAG: LOWER LINK	1
HB-916	HDWR BAG: 9/16 NII LOCK NUTS	1

#### Part # D2512

Item #	Description	Qty
R372S	DODGE RAM ADD-A-LEAF, SGL	2
1206	1/2 X 6 TIE BOLTS, PAIR W/NUTS	1
DLL23-L	LOWER LINK, DODGE RAM	2
BP40S	BUMP STOP, DODGE RAM	2
HB-LL1752	HDWR BAG: LOWER LINK	1

#### Part # D2513

Item #	Description	Qty
R332S	DODGE RAM ADD-A-LEAF, SGL	2
H-BOX D2513	HDWR BOX: D2513 COMP BOX	1

### Component Box Breakdown:

#### Part # D301

Item #	Description	Qty
R222S	DODGE RAM ADD-A-LEAF, SGL	2
3806	3/8 X 6 TIE BOLTS, PAIR W/NUTS	1
DLL23-L	LOWER LINK, DODGE RAM	2
BP40S	BUMP STOP, DODGE RAM	2
HB-LL175	HDWR BAG: LOWER LINK	1

#### Part # D301S

Item #	Description	Qty
916X212X834U	9/16 X 2-1/2 X 8-3/4 U-BOLT	4
DLL23-L	LOWER LINK, DODGE RAM	2
BP40S	BUMP STOP, DODGE RAM	2
HB-LL175	HDWR BAG: LOWER LINK	1
HB-916	HDWR BAG: 9/16 NII LOCK NUTS	1

#### Part # D3012

Item #	Description	Qty
R222S	DODGE RAM ADD-A-LEAF, SGL	2
3806	3/8 X 6 TIE BOLTS, PAIR W/NUTS	1
DLL23-L	LOWER LINK, DODGE RAM	2
BP40S	BUMP STOP, DODGE RAM	2
HB-LL1752	HDWR BAG: LOWER LINK	1

#### Part # H-BOX D2513

Item #	Description	Qty
1206	1/2 X 6 TIE BOLTS, PAIR W/NUTS	2
DLL23-L	LOWER LINK, DODGE RAM	2
BP40S	BUMP STOP, DODGE RAM	2
HB-LL1752	HDWR BAG: LOWER LINK	1
HB-D4510-LK	HDWR BAG: LOWER LINK 03-13	1

### Hardware Bag Breakdown:

#### Part # HB-916

Item #	Description	Qty
916FTN	9/16-18 NI LOCK NUT	8

#### Part # HB-LL175

Item #	Description	Qty
2617	BUSHING, LOWER LINK	8
LS2645	SLEEVE, LINK LOWER 2.645	4
ZF316	ALEMITE ZERK FITTING, 3/16	4

### Hardware Bag Breakdown:

#### Part # HB-LL1752

Item #	Description	Qty
2617	BUSHING, LOWER LINK	8
LS20DL	SLEEVE, LOWER LINK 2.645	4
ZF316	ALEMITE ZERK FITTING, 3/16	4

#### Part # HB-D4510-LK

Item #	Description	Qty
SP3643	BUSHING, LOWER LINK	4
LS2650	SLEEVE, LOWER LINK 2.65	2

### Pre-Installation Tips: Install Zerk Fittings, Bushings & Sleeves into Link Arms.

1. Install supplied Alemite Zerk Fitting into each end of Skyjacker Lower Link Arm. Drive-in Zerk fittings using a 1/4" socket over the fitting, strike slightly with a hammer until fitting is completely tapped in. **Tech Note:** Positioned Zerk fittings as follows: Front eye of link = fitting pointing forward toward end. Rear eye of link = fitting pointing downward.
2. On # DLL23-L Lower Links, Coat # 2617 Lower Link Bushings with a water resistant grease & press into each link arm eye. Coat # LS2645 2.645" Long Sleeve & press into link arm eye bushings.



*With Skyjacker Upper Link Arm Option:*

3. On # DUL25-L Upper Links, Coat # 2618 Link Bushings with a water resistant grease & press into each link arm eye. Coat # LS2375 2.375" Long Sleeve & press into link arm eye bushings.

### Pre-Installation Tips: Install Shock Boots, Bushings & Sleeves.

1. Install supplied Shock Boot over Skyjacker Shock. Attach boot to cylinder body with supplied Boot Cable Tie. Remove excess cable tie with diagonal cutting pliers.
2. Coat Hourglass Bushings with a water resistant grease & press into each shock eye. Coat Sleeve & press into shock eye bushings.

### Front Installation: **Note:** Save all factory components & hardware for reuse, unless noted.

1. Chock rear tires\wheels. Ensure that vehicle transmission is in PARK and engage emergency brake. **Note:** Be sure steering wheel\wheels are pointing straight forward.
2. From inside the engine compartment, disconnect both OEM front shock upper stud mounts from upper shock tower bracket using a 14mm socket\wrench. (Photo # 1)

**Note:** OEM shocks will be removed when OEM coils are removed.

Remove three (3) bolts from OEM upper shock tower bracket. Remove bracket. (Photo # 2)

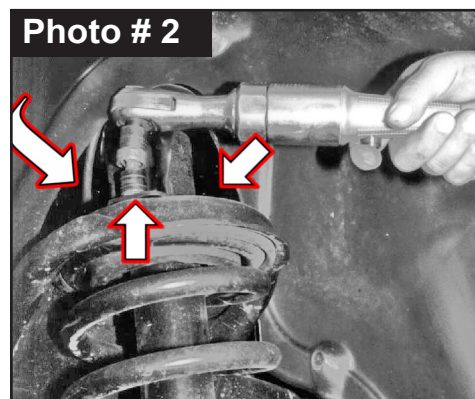

3. Loosen OEM front track bar from lower passenger side axle mount. Disconnect OEM front track bar from upper frame mount using a 24mm socket \ wrench. (Photo # 3)

**Tech Note:** It may be necessary to turn steering wheel to help remove bolt.

4. Raise front of vehicle, support frame rails using jack stands at indicated lift points in OEM service manual.

**Tech Note:** Do Not place jack stands on frame between lower control arms & transmission crossmember.

5. Remove the front tires \ wheels using a 22mm socket.
6. Place a floor jack underneath front axle for support. Put a slight load on axle \ jack to prevent axle from moving. Allow ample room to lower front axle.

#### **Without Replacement Drop Pitman Arm:**

7. Remove cotter pin from drag link end at OEM pitman arm. Disconnect OEM drag link assembly from OEM pitman arm using a 24mm socket \ wrench. (Photo # 4)

Use a tie rod remover tool to detach drag link from pitman arm. Take caution not to tear the drag link grease boot.

**Proceed to Step 11.**

#### **With Optional Skyjacker # DA300 \ # DA302 Drop Pitman Arm:**

8. Remove OEM steering stabilizer from passenger side frame mount & from drag link \ tie rod assembly stud mount.

**Note:** OEM stabilizer cannot be reinstalled when using a drop pitman arm. A replacement Single or Dual Stabilizer Kit is available from SKYJACKER®.

9. Remove cotter pin from drag link end at OEM pitman arm. Disconnect OEM drag link assembly from OEM pitman arm using a 24mm socket \ wrench. (Photo # 4)  
Use a tie rod remover tool to detach drag link from pitman arm. Take caution not to tear the drag link grease boot.
10. Mark position of OEM pitman arm on steering gear box sector shaft. Transfer an index mark over to Skyjacker pitman arm.

Remove OEM nut & washer from steering gear box using a 33mm socket \ wrench.

Use a pitman arm puller tool to remove pitman arm from OEM steering gear shaft. (Photo # 5)

Align marks & splines on the Skyjacker # D300 \ # DA302 Pitman Arm with sector shaft for correct indexing & install. Attach with OEM washer & nut. Tighten using 33mm socket \ wrench. Torque 177-185 ft-lbs. **Proceed to Step 11.**

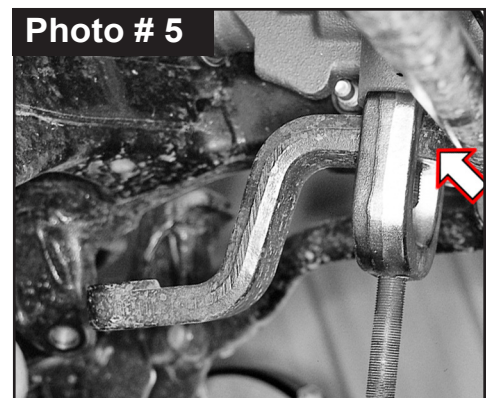
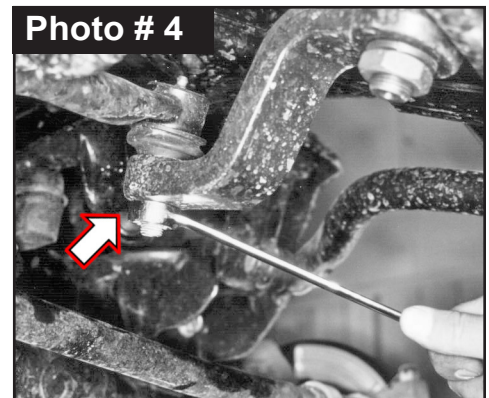
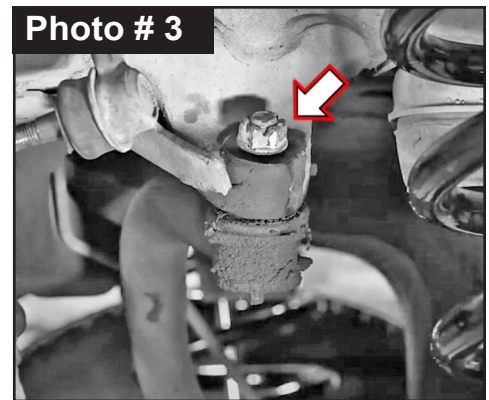

11. On Driver & Passenger sides, loosen, but do not remove, OEM front sway bar from OEM frame mounts using a 15mm socket \ wrench. (Photo # 6)

Remove OEM front sway bar upper links from OEM sway bar using a 15mm socket \ wrench. (Photo # 7) Remove OEM hardware & bushings from sway bar studs. Roll sway bar downward.

12. On Driver & Passenger sides, scribe alignment marks on OEM adjustable cam bolts. Mark cams with DR & PA to indicate driver & passenger side *Marks are used for installation reference.* (Photo # 8)

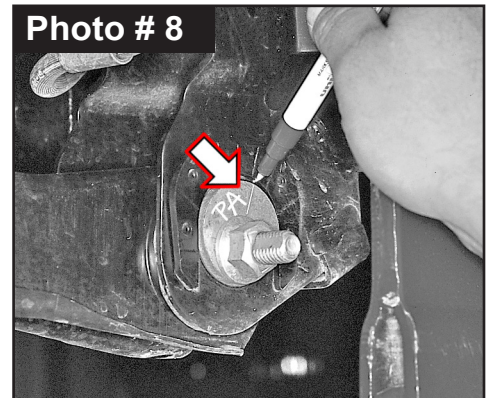
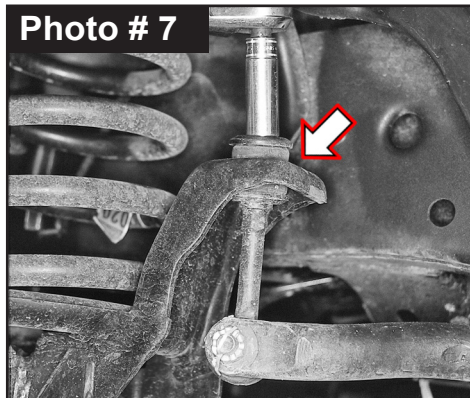
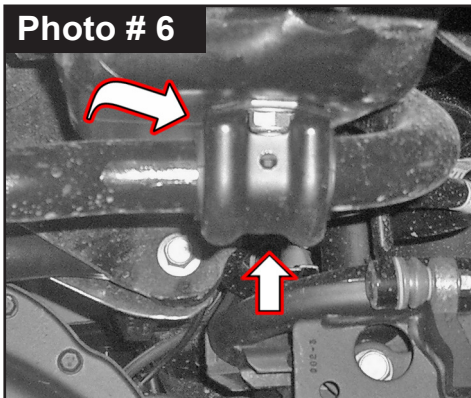

13. On Driver & Passenger sides, remove OEM brake line bracket from axle mount behind coil & between upper & lower links using a 13mm socket \ wrench. (Photo # 9)

**Note:** Perform Steps 14-20 on One Side at a Time.

14. Disconnect OEM front shock lower mount using a 21mm socket \ wrench. Bolt is accessed through a hole in front of axle spring perch. Retain OEM hardware.

While checking for appropriate slack in ABS lines, brake lines, differential vent hose & etc, lower the front differential until OEM front coil spring become loose.

Remove OEM coil spring, OEM spring isolator, OEM 3-bolt shock tower ring & front shock. (Photo # 10)

**Tech Note:** If front axle cannot be lowered enough to allow coil spring to be installed, carefully rotate the pinion up to provide more clearance.

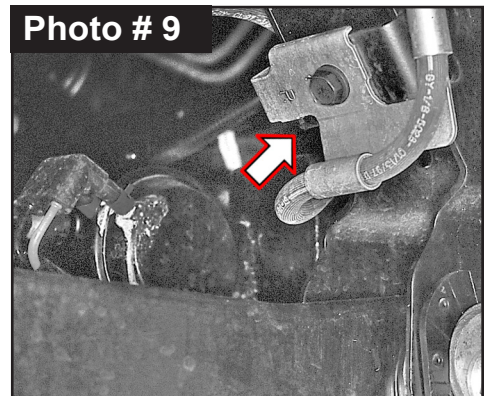

15. Locate OEM front rubber bump stops, mounted on OEM frame rail behind the coils. (Photo # 11) Remove bump stop from it's pocket by using a large flat screwdriver to pry bushing out or using a pair of channel lock pliers working bushing back & forth.

16. Remove & replace OEM lower link arm.

First, disconnect lower link arm at axle mount using a 21mm & a 24mm socket \ wrench. (Photo # 12)

Next, disconnect lower link arm at frame mount using a 21mm & a 1-1/16 socket \ wrench. (Photo # 13)

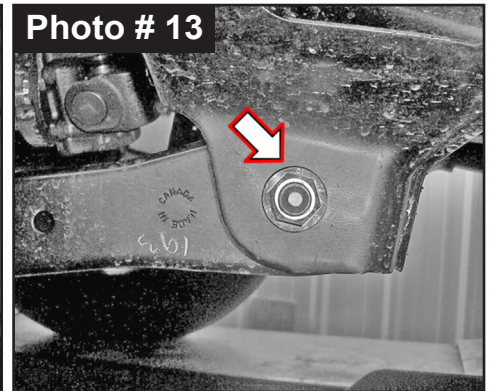
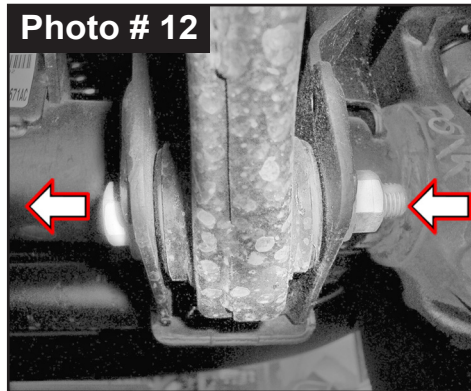

Attach Skyjacker # DLL23-L Lower Link Arm with OEM hardware at axle mount using a 21mm & a 24mm socket \ wrench. **Note:** Be sure OEM brake line is running above lower control arm & under upper control arm. **Tech Note:** Positioned Zerk fittings as follows: Front eye of link = fitting pointing forward toward end. Rear eye of link = fitting pointing downward.

Attach Skyjacker # DLL23-L Lower Link Arm with OEM hardware at frame mount using a 21mm wrench & a 1-1/16 socket \ wrench. Secure, but **Do Not Completely Tighten** links at this time. To set bushings properly for ride height, these will be tightened once vehicle is on ground with full vehicle weight on tires \ wheels.

**CAUTION:** GREASE Skyjacker Lower Link Arm Bushings using a grease gun.

**With Optional Skyjacker Upper Link Arms:**

17. Remove & replace OEM upper link arm with Skyjacker # # DUL25-L Upper Link Arm. First, disconnect upper link arm at axle mount using a 21mm socket \ wrench. Next, disconnect upper link arm at frame mount using a 21mm socket \ wrench.

Slide Skyjacker Upper Link Arm front eye into OEM axle mount, then slide rear eye into OEM frame mount. Secure rear frame mount first with OEM hardware using a 21mm socket \ wrench. Attach front eye mount to OEM axle mount using a 21mm socket \ wrench. Secure, but **Do Not Completely Tighten** links at this time.

**CAUTION:** GREASE Skyjacker Upper Link Arm Bushings using a grease gun.

18. **Note:** Skyjacker Front Coil Springs Beginning with **D3** Are Side Specific & Must Be Installed on Appropriate Side: Part Number Is Paint Stamped on Each Coil Spring & Labeled Driver or Passenger. *1/2 Ton & Light 3/4 Ton Vehicle WITHOUT V10 \ Cummins Engine.*

**Note:** Skyjacker Front Coil Springs Beginning with **D2** Are Not Side Specific: Part Number Is Paint Stamped on Each Coil Spring. *Heavy 3/4 Ton & 1 Ton Vehicle With V10 \ Cummins Engine.*

To begin coil spring installation, place OEM 3-bolt shock tower ring inside top of coil tower & attach with OEM nuts. Hand Tighten Only just to hold ring in place.

19. Install Skyjacker Front Coil Spring to appropriate side of vehicle.

Place OEM spring isolator on top of Skyjacker Front Coil Spring. (Photo # 10)

Insert coil spring into upper tower first. Be sure bottom coil spring wrap is turned to the inside at the center of the axle. Be sure coil spring is indexed to seat properly.

**Tech Note:** If the front axle cannot be lowered enough to allow the coil spring to be installed, carefully rotate the pinion up to provide more clearance for the coil installation.

Raise axle enough to hold the coil springs in place.

**WARNING:** On Dodge Ram trucks, SKYJACKER® replacement front shock absorbers limit extended position of the front suspension! The use of shocks other than those supplied, may cause coil disengagement, adverse steering angles, brake line failure, driveline component failure and \ or other related component failure! The use of other shocks will void your SKYJACKER® Warranty!

20. Now remove OEM nuts from 3-bolt shock tower ring.  
 From inside the engine compartment, install Skyjacker shock down through coil spring tower.  
 Place supplied retaining washer & poly stem bushing onto shock stem.  
 Install OEM upper shock tower bracket onto 3-bolt shock ring with OEM nuts. (Photo # 2)  
 Extend shock stem up through OEM upper shock tower bracket.  
 Place supplied poly stem bushing & retaining washer onto shock stem.  
 Attach with supplied lock nut using a 5/8" socket \ wrench.  
 Attach shock lower mount at axle with OEM hardware using a 21mm socket \ wrench.

**Note:** Perform Steps 14-20 on Opposite Side at This Time, Then Proceed to Step 21 or 22.

**Without Replacement Drop Pitman Arm:**

21. Connect OEM drag link assembly down into OEM pitman arm. (Photo # 14) Tighten using a 24mm socket \ wrench. Torque 185 ft-lbs. Align & install cotter pin into castle nut.  
 Connect OEM steering stabilizer or install SKYJACKER® replacement steering stabilizer.

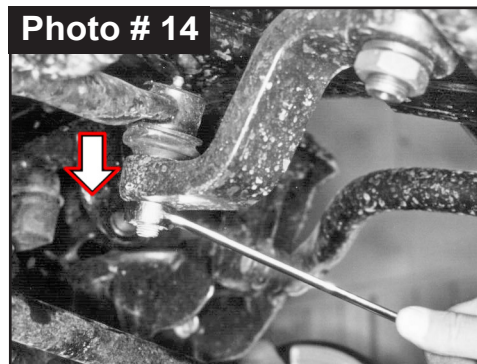

**With Optional Skyjacker # DA300 \ # DA302 Drop Pitman Arm:**

22. Loosen adjuster clamps on OEM drag link. Rotate drag link end to pitman arm 180°. Attach drag link end up through bottom of Skyjacker pitman arm. (Photo # 15) Tighten using a 24mm socket \ wrench. Torque 185 ft-lbs. Align & install cotter pin into castle nut.

Rotate drag link adjuster clamps 'up' to topside of drag link adjuster sleeve for clearance. (Photo # 16)  
 Tighten clamps into place.

**Note:** OEM stabilizer cannot be reinstalled. Install SKYJACKER® replacement Single or Dual Stabilizer Kit per separate instructions.

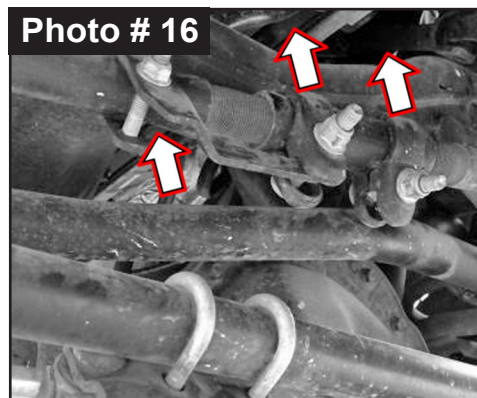

23. Roll OEM sway bar upward. Connect OEM sway bar link upper studs to OEM sway bar with OEM hardware & bushings. (Photo # 17) Secure, but **Do Not Completely Tighten** this time.  
 Tighten OEM sway bar at OEM frame mounts using a 15mm socket \ wrench. (Photo # 18)

24. Connect OEM brake line brackets to each Driver & Passenger side axle mount between upper & lower links with OEM hardware using a 13mm socket \ wrench. (Photo # 19)

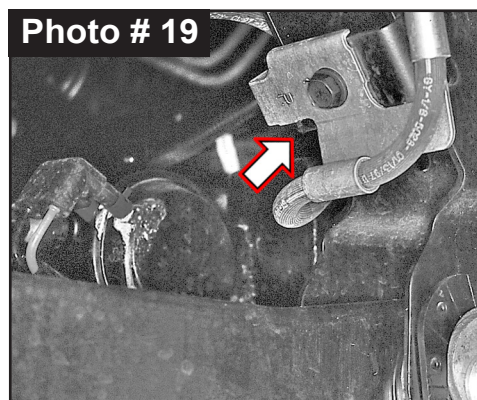
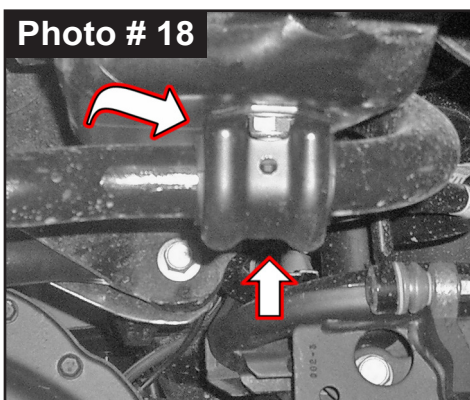
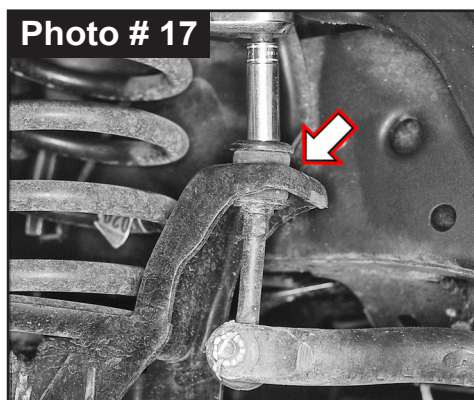

25. Install front tires\wheels using a 22mm socket. Lower vehicle to ground. Torque lugs to OEM service manual specifications.
26. On Driver & Passenger sides, install Skyjacker # BP40S Poly Bump Stops. Place Poly Bump Stop into OEM bump stop cup. By using leverage against the bottom of bump stop, force the bump stop up into place. **Tech Note:** Use a flat block or 2x4 for better leverage. (Photo # 20)
27. Make sure that tires\wheels are pointed straight ahead. Connect OEM front track bar to upper frame mount using a 24mm socket\wrench. (Photo # 3) Secure, but **Do Not Completely Tighten** this time. **Tech Note:** It may be helpful to turn steering wheel to align track bar end with mount.

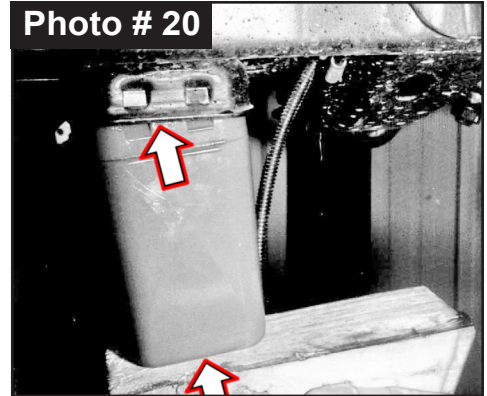

**Rear Installation: Note: Save all factory components & hardware for reuse, unless noted.**

1. Chock front tires\wheels. Raise rear of vehicle & support frame rails using jack stands at indicated lift points in OEM service manual.
2. Remove rear tires\wheels using a 22mm socket.
3. Place a floor jack underneath rear axle for support. Put a slight load on axle\jack to prevent axle from moving. Allow ample room to lower rear axle.
4. Remove OEM rear shocks. Retain factory mounting hardware for re-use.
5. Remove OEM U-bolts. Discard U-bolts & hardware. Retain lower OEM U-bolt plate.
6. While checking for appropriate slack in brake lines, sway bar, E-brake lines, differential breather hose, & etc, lower axle several inches away from leaf springs.  
If equipped, remove OEM block or OEM steel plates.

**Rear Lift Option 1: Add-A-Leaf Installation**

**Note: Perform Steps 7-11 on One Side at a Time.**

7. Loosen OEM leaf spring mounts. Loosen front spring eye bolt. Loosen rear spring eye bolt. Loosen shackle eye bolt.

**Note:** Installation of Skyjacker Add-A-Leafs properly, you must use two (2) large C-clamps to contain elastic potential energy of OEM leaf springs when OEM tie bolts are being removed.

**Tech Note:** Spray a good penetrating oil onto each tie bolt to help loosen nut.

Attach C-clamp on each side of OEM leaf spring center tie bolt to hold leaf spring assembly securely together. Tighten C-clamp equally on each side. (See Photo # 1)

**Tech Note:** If bend clips \ straps that hold OEM leaf spring pack together must be disturbed, do these first, then remove the spring center bolt.

Use locking pliers to hold head of OEM tie bolt. Use a wrench to loosen & remove nut. Remove tie bolt.

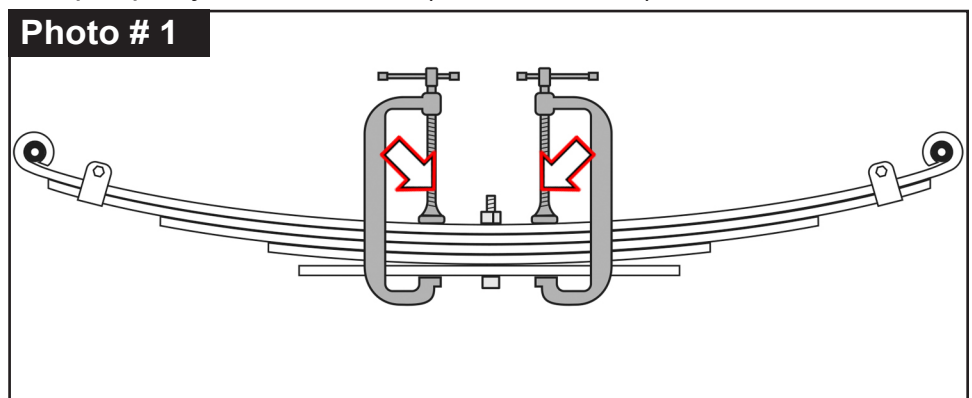

8. Carefully & slowly loosen C-clamps equally on each side until leaf spring expands completely. Remove C-clamps.

Separate leafs & install Skyjacker Add-A-Leaf into spring pack so leaves remain progressive (longest at top & shortest to bottom). (See Photo # 2)

Center pin is offset. Install long end of add-a-leaf to rear OEM leaf spring offset.

**Photo # 2**

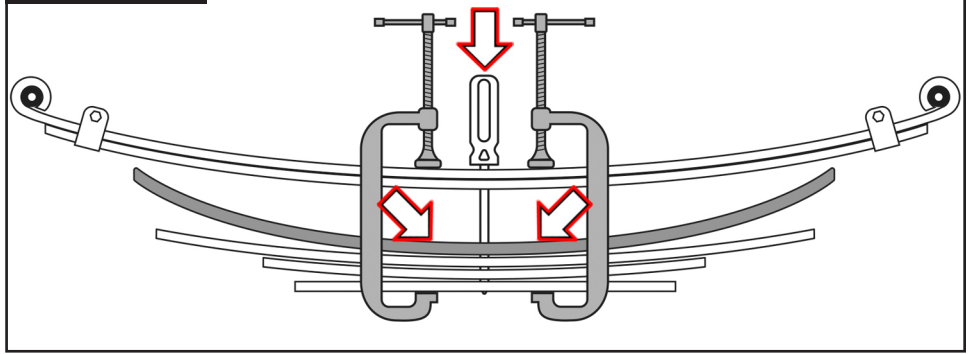

**Tech Note:** Lower rear axle as needed to allow add-a-leaf to be installed.

9. Attach C-clamp on each side of tie bolt hole to hold leaf spring assembly. (See Photo # 2) Use an alignment bar \ screwdriver to line up tie bolt hole in leaf spring pack. It is recommended to leave the alignment bar \ screwdriver in to help keep the leaves aligned as you tighten the C-clamps.

**CAUTION: Do Not Use Skyjacker Tie Bolts to Draw OEM Leaf Springs Together. Failure of Any Component Can Cause an Explosive Disassembly & Possible Injury!**

10. Tighten C-clamps equally on each side until leaf spring compresses enough to install supplied Skyjacker tie bolt up through bottom of leaf spring. (See Photo # 3) With tie bolt installed, tighten nut by hand. Then continue to tighten C-clamps.

**Photo # 3**

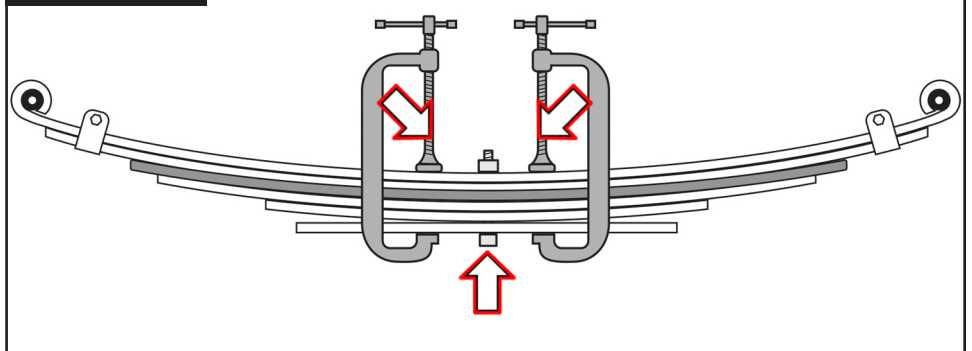

11. Once C-clamps have drawn leaves securely together, use locking pliers to hold tie bolt head & tighten tie bolt nut with a wrench. **Caution:** Do not use an air gun to tighten tie bolt. An air gun could strip or over torque \ stretch tie bolt.

**Torque Specifications:** 3/8" Tie Bolt = 17 ft lbs. \ 204 in lbs. 1/2" Tie Bolt = 41 ft lbs.

**Note:** Make sure individual leafs are all in-line with each other. If applicable, re-form bend clips \ straps or install new bend clips. If heat is used on straps, allow straps to cool naturally & thoroughly before removing the C-clamps.

Remove C-clamps. Cut off any excess tie bolt length with cut-off tool or hacksaw.

**Note: Perform Steps 7-11 on Opposite Side at This Time, Then Proceed to Step 12.**

12. Clean spring pads of all debris. Raise axle to mate leaf springs axle pad & OEM block.

**Note:** Be sure that leaf spring center bolt head seats properly into OEM block & that OEM block pin seats properly into top of axle pad.

13. Install OEM U-bolts \ hardware & OEM u-bolt plate. Tighten u-bolts evenly using an 'X' crisscross tightening sequence. Torque to OEM specifications.

14. Install OEM shocks. Secure, but **Do Not Completely Tighten.**

15. Install rear tires \ wheels using a 22mm socket. Lower vehicle to ground. Torque lugs to OEM service manual specifications.

### **Rear Lift Option 3: Replacement Softride® Leaf Spring Installation**

16. To access Driver side front spring eye bolt, the OEM fuel tank must be loosened & pried away from OEM frame to gain clearance.

**Caution:** Do Not pry fuel tank over too much or lower it down too far to protect top OEM fittings from damage.

Safely support fuel tank. Loosen vent & fill hoses on filler neck. Loosen, but do not remove, OEM fuel tank front strap bolt.

Disconnect & remove OEM fuel tank rear bolt & strap.

Carefully slide \ pry fuel tank away from frame toward center of vehicle to acquire sufficient room to access Driver side front spring eye bolt.

**Photo # 4**

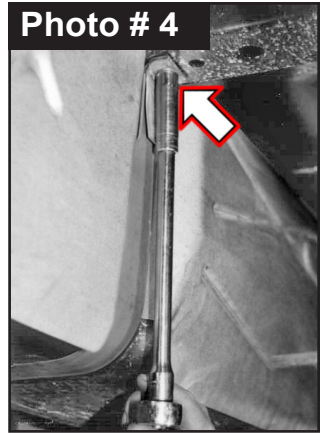

**Note:** Perform Steps 17 on One Side at a Time.

17. **Note:** Direction of OEM hardware into springs. Loosen front spring eye bolt. Loosen rear spring eye bolt. Loosen rear shackle eye bolt.

Disconnect spring eye bolts & remove leaf spring with rear shackle attached.

Attach 'short' end of Skyjacker leaf spring to forward frame mount with OEM hardware.

Attach 'long' end of Skyjacker leaf spring to rear shackle & rear shackle mount with OEM hardware. **Note:** On Skyjacker springs with a bottom degree shim, place taller end of shim toward rear of vehicle.

Secure OEM hardware, but **Do Not Completely Tighten** leaf spring hardware at this time.

**Note:** Perform Steps 17 on Opposite Side at This Time, Then Proceed to Step 18.

18. Clean spring pads of all debris. Raise axle to mate leaf springs axle pad. **Note:** OEM block or OEM steel plates Are Not Reinstalled with Replacement Softride® Leaf Springs.

**Note:** Be sure that leaf spring center bolt head seats properly into top of axle pad.

19. Reconnect Driver side rear fuel tank strap & bolt. Tighten front fuel tank strap bolt. Tighten vent & fill hoses on filler neck.

20. Install Skyjacker 9/16" U-bolts over axle up into OEM U-bolt plate. Install supplied 5/8" Nylon Insert Nuts using a 13/16" socket \ wrench. Tighten U-bolts evenly using an 'X' crisscross tightening sequence. Torque to 175 ft-lbs.

21. Install Skyjacker rear shock with OEM hardware at upper shock tower mount. Connect Skyjacker shock at lower axle mount with OEM hardware. Secure, but **Do Not Completely Tighten** at this time. To set bushings properly for ride height, these will be tightened once vehicle is on ground with full vehicle weight on tires \ wheels.

22. Install rear tires \ wheels using a 22mm socket. Lower vehicle to ground. Torque lugs to OEM service manual specifications.

## **Final Clearance Check & Torque Steps:**

1. Jounce vehicle a couple of times. This will help suspension settle to new ride height. Cycle steering lock-to-lock & check all components for proper operation & clearances. Pay special attention to clearance between tires\wheels, shocks, brake hoses, ABS wiring, etc.
2. **Front Tighten & Torque Sequence.**  
Front track bar at frame using a 24mm socket \wrench. Torque 110 ft-lbs.  
Front shock absorber upper mount using a 5/8" socket \wrench. Torque 35 ft-lbs.  
Front shock absorber lower mount using a 21mm socket \wrench. Torque 100 ft-lbs.  
Front sway bar mount at frame using a 15mm socket \wrench. Torque 40 ft-lbs.  
Front sway bar end link upper stud bolt using a 15mm socket \wrench. Torque 27 ft-lbs.  
Front upper link arm at axle mount using a 21mm socket \wrench. Torque 120 ft-lbs.  
Front upper link arm at frame mount using a 21mm socket \wrench. Torque 120 ft-lbs.  
Front lower link arm at axle mount using a 21mm & 24mm socket \wrench. Torque 140 ft-lbs.  
Front lower link arm at frame mount using a 21mm & 1-1/16 socket \wrench. Torque 140 ft-lbs.
3. **Rear Tighten & Torque Sequence.**  
Rear shock absorber upper mount & lower mount. Torque 100 ft-lbs.  
Tighten Leaf Springs in this sequence:  
Front spring eye bolt. Rear spring eye bolt. Rear shackle eye bolt. Torque 110 ft-lbs.

## **Final Notes:**

- After installation is complete, double check that all nuts & bolts are tight. Refer to following chart for proper torque specifications.
- With vehicle placed on ground, cycle steering lock to lock & inspect steering, suspension, brake lines, front & rear drivelines, fuel lines & wiring harnesses for proper operation, tightness & adequate clearance.
- Have headlights readjusted to proper settings.
- Have a qualified alignment center align vehicle to OEM specifications.
- After first 100 miles, check all hardware for proper torque & periodically thereafter.

<b>TORQUE SPECIFICATIONS</b>					
<b>INCH SYSTEM</b>			<b>METRIC SYSTEM</b>		
<b>Bolt Size</b>	<b>Grade 5</b>	<b>Grade 8</b>	<b>Bolt Size</b>	<b>Class 8.8</b>	<b>Class 10.9</b>
5/16	180 in-lbs	240 in-lbs	6MM	60 in-lbs	108 in-lbs
3/8	30 ft-lbs	35 ft-lbs	8MM	216 in-lbs	23 ft-lbs
7/16	45 ft-lbs	60 ft-lbs	10MM	32 ft-lbs	45 ft-lbs
1/2	65 ft-lbs	90 ft-lbs	12MM	55 ft-lbs	75 ft-lbs
9/16	95 ft-lbs	130 ft-lbs	14MM	85 ft-lbs	120 ft-lbs
5/8	135 ft-lbs	175 ft-lbs	16MM	130 ft-lbs	165 ft-lbs
3/4	185 ft-lbs	280 ft-lbs	18MM	170 ft-lbs	240 ft-lbs

**The Above Specifications Are Not to Be Used  
When the Bolt Is Being Installed With a Bushing.**

**Seat Belts Save Lives. Please Wear Your Seat Belt.**



**JESUS FORGIVES ROCKS DON'T**

### *Jesus Christ Died For You.*

John 3:16

For God so loved the world that He gave His only Son, so that everyone who believes in Him should not perish, but have everlasting life.  
Romans 3:23

For all have sinned; all fall short of God's glorious standard.  
Ephesians 2:8

God saved you by his special favor when you believed. And you can't take credit for this; it is a gift from God.  
Psalms 18:2

The Lord is my Rock, my fortress, and my savior; my God is my Rock, in whom I find protection. He is my shield, the strength of my salvation, and my stronghold.  
Romans 10:9-10

That if you shall confess with thy mouth the Lord Jesus, and shall believe in your heart that God hath raised him from the dead, you shall be saved. For with the heart man believeth unto righteousness; and with the mouth confession is made unto salvation.

#### Pray This Simple Prayer:

God, I come to You admitting I have sinned against You and I need you to take control of my life. The Bible says anyone who calls on the name of the Lord will be saved. I am calling on You, Jesus. I ask that You come live in my heart and be the Lord over my life today. I do believe You died on the cross for me and came back to life to give me life! Thank You, Lord Jesus for a new life in You!

Now, go and tell somebody about your new life in Jesus, get a Bible, begin to read it, and go to a Bible believing church.

If you would like someone to pray with you, call Kenneth Copeland Ministries anytime at 800-600-7395.

To listen to commercial free Christian radio on the web, go to [www.887fm.org](http://www.887fm.org)

### *Jesús murió por ti.*

Juan 3:16

“Porque tanto amó Dios al mundo, que dio a su Hijo unigénito, para que todo el que cree en él no se pierda, sino que tenga vida eterna.”  
Romanos 3:23

“Pues todos han pecado y están privados de la gloria de Dios.”  
Efesios 2:8

“Porque por gracia ustedes han sido salvados mediante la fe; esto no procede de ustedes, sino que es el regalo de Dios.”  
Salmos 18:2

“El Señor es mi roca, mi amparo, mi libertador; es mi Dios, el peñasco en que me refugio. Es mi escudo, el poder que me salva, ¡mi más alto escondite!”  
Romanos 10:9-10

“9 Que si confi esas con tu boca que Jesús es el Señor, y crees en tu corazón que Dios lo levantó de entre los muertos, serás salvo. 10 Porque con el corazón se cree para ser justifi cado, pero con la boca se confi esa para ser salvo.”

#### Ahora dí esta simple oración:

Dios, vengo a Ti y admito que he pecado contra Ti, necesito que tomes el control de mi vida. La Biblia dice que todo aquel que invoca el nombre del Señor escapará con vida. En este momento yo clamo ante Ti, Jesús; te pido que vengas a vivir en mi corazón y que tomes el control de mi vida. ¡Yo creo que tu moriste en la cruz y resucitaste para darme vida! ¡Gracias Señor Jesús, por una nueva vida que tengo en Ti! Amen.

Ahora ve y dile a alguien sobre la nueva vida que tienes en Cristo. Compra una Biblia y empieza a leerla. Busca una Iglesia que cree en la Biblia y hazte parte de esa Iglesia.

Si te gustaría orar con alguien, puedes llamar a este número 800-600-7395

Puedes ir a este sitio de Internet para escuchar música Cristiana sin anuncios, [www.887fm.org](http://www.887fm.org)

### Check out our favorite ministries at:



[www.innministries.org](http://www.innministries.org)  
[www.familychurch.org](http://www.familychurch.org)  
[www.kcm.org](http://www.kcm.org)