



www.skyjacker.com

**REQUIRED TOOL LIST:**

- \* Safety Glasses
- \* Metric / Standard Wrenches & Sockets
- \* Allen Wrenches
- \* Drill & Assorted Drill Bits
- \* Floor Jack
- \* Jack Stands
- \* Measuring Tape
- \* Torque Wrench
- \* Reciprocating Saw
- \* Grinder

**2007- 2013 GM 1500  
Pick-Up / SUV 4WD  
6" Suspension Lift  
Installation Instructions**



Before beginning the installation, thoroughly & completely read these instructions & the enclosed driver's WARNING NOTICE. Affix the WARNING decal in the passenger compartment in clear view of all occupants. Please refer to the Parts List to insure that all parts & hardware are received prior to the disassembly of the vehicle. If any parts or hardware are found to be missing, contact SKYJACKER® Customer Service at 318-388-0816 to obtain the needed items. If you have any questions or reservations about installing this lift kit, contact SKYJACKER® Technical Assistance at 318-388-0816.

Make sure you park the vehicle on a level concrete or asphalt surface. Many times a vehicle is not level (side-to-side) from the factory & is usually not noticed until a lift kit has been installed, which makes the difference more visible. Using a measuring tape, measure the front & rear (both sides) from the ground up to the center of the fender opening above the axle. Record this information below for future reference.

Driver Side Front: \_\_\_\_\_ Passenger Side Front: \_\_\_\_\_

Driver Side Rear: \_\_\_\_\_ Passenger Side Rear: \_\_\_\_\_

**IMPORTANT NOTES:**

- If larger tires (10% more than the stock diameter) are installed, speedometer recalibration will be necessary. Contact your local GM dealer or an authorized dealer for details.
- After installation, a qualified alignment facility is required to align the vehicle to the OEM specifications.

## Component Box Breakdown:

### Part #: C7661A

Item #	Description	Qty
C1466L-S	6" GM 1500, DRV KNUCKLE	1
C1466R-S	6" GM 1500, PASS KNUCKLE	1
C7662FCM-B	6" GM 1500 FRONT X-MEMBER	1

Item #	Description	Qty
C7662RCM-B	6" GM 1500 REAR X-MEMBER	1
C766SKD-S	6" GM 1500 DIFF SKID PLATE	1
H-BOX C7661A	HDWR BOX: C7661A COMP BOX	1

## Hardware Box Breakdown:

### Part # H-BOX C7661A

Item #	Description	Qty
C766CVS-S	6" GM FRONT CV SPACER	2
C766FDS-D	6" GM 1500 DRV DIFF BRACKET	1
C766FDS-P	6" GM 1500 PAS DIFF BRACKET	1
C766SBL-S	GM OE STYLE SWAY BAR LINK	2
C736SBL	GM SWAY BAR LOW SPACER	2
C766TA-NG	6" GM TORQUE ARM LINK	1
C1466RBB-S	6" GM REAR BRAKE LINE EXT	1

Item #	Description	Qty
FBL83	GM 1500 FRONT BRAKE LINES	1
HB-C7662-CM	HDWR BAG: C7662 X-MEMBER	1
HB-C766-CVS	HDWR BAG: C766 CV SPACER	1
HB-C766-DS	HDWR BAG: C766 DIFF BRKTS	1
HB-C766-BL	HDWR BG: ABS/BRK/SWAY BRKT	1
HB-C766TA-NG	HDWR BG: C766TA-NG TOR ARM	1
HB-SKD	HDWR BAG: C766 SKID PLATE	1

## Hardware Bag Breakdown:

### Part # HB-C7662-CM

Item #	Description	Qty
58X412FTB	5/8 X 4 1/2 FINE THREAD BOLT	2
58X512FTB	5/8 X 5 1/2 FINE THREAD BOLT	2

Item #	Description	Qty
58FTN	5/8 FINE THREAD LOCK NUT	4
58SAEW	5/8 SAE WASHER	8

### Part # HB-C766-CVS

Item #	Description	Qty
10MMX70MMB	10MM X 70MM METRIC BOLT	12
LT100	NUTS N' BOLTS 427 1 ML TUBE	1

Item #	Description	Qty
6MMX12SHB	6MM X 12MM KNUCKLE BOLT	2
38HDCC-S	3/8 HEAVY DUTY CABLE CLAMP	2

### Part # HB-C766-DS

Item #	Description	Qty
12X2FTB	1/2 X 2 FINE THREAD BOLT	2
12SAEW	1/2 SAE WASHER	2
12FTN	1/2 FINE THREAD LOCK NUT	2
916X2CTB	9/16 X 2 COARSE THREAD BOLT	2

Item #	Description	Qty
916SAEW	9/16 SAE WASHER	4
916CTN	9/16 COARSE THRD LOCK NUT	2
C968SHIM	GM SHIM - PASS DIFF BRKT	1

## Part # HB-C766-BL

Item #	Description	Qty
C736ABS-B	GM FRONT ABS BRACKET	2
516X1FTB	5/16 X 1 FINE THREAD BOLT	3
516SAEW	5/16 SAE WASHER	6
516FTN	5/16" FINE THRD N/I LOCKNUT	3

Item #	Description	Qty
10MMX30MMB	10MM X 30MM METRIC BOLT	4
38SAEW	3/8 SAE WASHER	4
10MMN	10 MM LOCK NUT	4

## Part # HB-C766TA-NG

Item #	Description	Qty
HG58125	HOURGLASS 5/8" X 1.25" BUSH	1
403712	ES22 SLEEVE / 1.25" LONG	1
12X212FTB	1/2 X 2 1/2 FINE THREAD BOLT	1
12FTN	1/2 FINE THREAD LOCK NUT	1
12SAEW	1/2 SAE WASHER	2

Item #	Description	Qty
916X212FTB	9/16 X 2 1/2 FINE THREAD BOLT	1
916FTN	9/16 FINE THREAD LOCK NUT	1
916SAEW	9/16 SAE WASHER	2
BTIE-K	BLACK PLASTIC TIE	2

## Part # HB-SKD

Item #	Description	Qty
516X1FTB	5/16 X 1 FINE THREAD BOLT	4
516FTN	5/16 FINE THREAD LOCK NUT	4

Item #	Description	Qty
516SAEW	5/16 SAE WASHER	8

## Component Box Breakdown:

### Part #: C7660SP

Item #	Description	Qty
C760MS-B	6" GM 1500 FRONT SPACER	2
HB-10MM/NFN	HDWR BAG: 10MM FLANGE NUTS	1

Item #	Description	Qty
I-C766SP	INST SHEET: 6" 07-09 GM1500	1

## Hardware Bag Breakdown:

### Part # HB-10MM/NFN

Item #	Description	Qty
10MMX1.5NFN	10MM X 1.5 FLANGE NUT	6

## Component Box Breakdown:

### Part #: C7661PR (Pick Up Models)

Item #	Description	Qty
RB45	4.5" REAR BLOCK	2

Item #	Description	Qty
916X212X1312	U-BOLT WITH 9/16 FINE THRD NUTS	4

## Component Box Breakdown:

### Part #: C7661PRS (Pick Up Models)

Item #	Description	Qty
916X212X1012U	U-BOLT WITH 9/16 FINE THRD NUTS	4

## Component Box Breakdown:

### Part #: C7661SR (SUV Models)

Item #	Description	Qty	Item #	Description	Qty
ARLBD-B	GM SUV REAR DRV LK BRK	1	HB-C963RCAB	HDW BAG:C963 RR CONTROL BRK	1
ARLBP-B	GM SUV REAR PAS LK BRK	1	HB-C963RBS	HDWR BAG:C963 RR BUMP STOPS	1
ARBP42-B	GM SUV REAR BUMP STOP	2	HB-RSBL963	HDWR BAG:C963 REAR END LKS	1
C766RTB-B	6" GM REAR TRK BAR BRKT	1	HB-C766RTB	HDWR BAG:C766 REAR TRK BRKT	1
SBE506-L	REAR,SWAY BAR END LINK	2	C50RS	GM 4-5" SUV COIL SPRING	2

## Hardware Bag Breakdown:

### Part # HB-C963RCAB

Item #	Description	Qty	Item #	Description	Qty
916X312FTB	9/16 X 3 1/2 FINE THREAD BOLT	2	12FTN	1/2 FINE THREAD LOCK NUT	2
916X4FTB	9/16 X 4 FINE THREAD BOLT	2	916SAEW	9/16 SAE WASHER	8
12X114FTB	1/2 X 1 1/4 FINE THREAD BOLT	2	12SAEW	1/2 SAE WASHER	4
916FTN	9/16 FINE THREAD LOCK NUT	4	SS1545	SLEEVE: ARLBD-B DRIVER	1

### Part # HB-C963RBS

Item #	Description	Qty	Item #	Description	Qty
716X1FTB	7/16 X 1 FINE THREAD BOLT	4	716SAEW	7/16 SAE WASHER	8
716FTN	7/16 FINE THREAD LOCK NUT	4			

### Part # HB-RSBL963

Item #	Description	Qty	Item #	Description	Qty
HOURGLASS 5/8	HOURGLASS 5/8 BUSHING	4	12SAEW	1/2 SAE WASHER	8
142121	ES24 SLEEVE, 1.38" LONG	4	38X1FTB	3/8 X 1 FINE THREAD BOLT	2
12X3FTB	1/2 X 3 FINE THREAD BOLT	4	38FTN	3/8 FINE THREAD LOCK NUT	2
12FTN	1/2 FINE THREAD LOCK NUT	4	38SAEW	3/8 SAE WASHER	2

### Part # HB-C766RTB

Item #	Description	Qty	Item #	Description	Qty
916X112FTB	9/16 X 1 1/2 FINE THREAD BOLT	1	916SAEW	9/16 SAE WASHER	4
916X312FTB	9/16 X 3 1/2 FINE THREAD BOLT	1	916FTN	9/16 FINE THREAD LOCK NUT	2

## **Front Installation:**

1. With the vehicle on flat level ground, set the emergency brake & block the rear tires / wheels. Place a floor jack under the lower control arm's front cross member & raise the front of the vehicle. Place jack stands under the frame rails behind the front wheel wells & lower the frame onto the jack stands.
2. Remove the front tires / wheels using a 22mm socket. (See Photo # 1)
3. Remove the OEM tie rod end nuts from the OEM steering knuckles using a 18mm socket. Remove the OEM tie rod ends from the OEM steering knuckles using a tie rod puller or similar tool. (See Photo # 2)
4. Remove the OEM brake calipers from the OEM rotors & disconnect the OEM brake lines from the OEM upper A-arms. (See Photo # 3) Simply wire the OEM brake calipers out of the way. It will not be necessary to disconnect the OEM brake lines from the OEM brake calipers at this time.
5. Remove the OEM sway bar end links using a 15mm socket & remove the OEM sway bar. (See Photo # 4) Remove the three OEM upper strut retaining nuts using a 18mm socket. (See Photo # 5)
6. Disconnect the OEM upper & lower A-arms from the OEM steering knuckles using a 18mm socket. It may be necessary to strike the side of the steering knuckle to dislodge the OEM ball joints. Be careful not to damage the OEM ball joints. (See Photo # 6)



**Photo # 1**

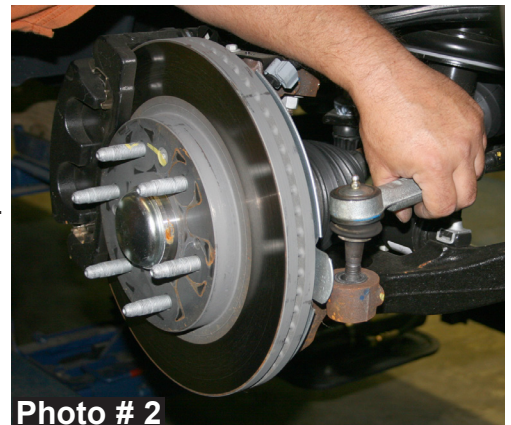

**Photo # 2**



**Photo # 3**



**Photo # 4**



**Photo # 5**

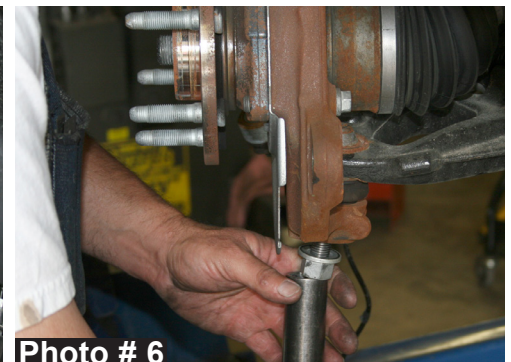

**Photo # 6**

7. Remove the OEM CV axles using a 15mm socket. (See Photo # 7)
8. Remove the OEM front skid plates using a 15mm socket. Remove the OEM lower A-arms using a 18mm & 24mm socket.
9. Remove the OEM rear cross member using a 18mm socket. (See Photo # 8)
10. Disconnect the OEM front drive shaft from the front differential & support the front differential using a transmission jack. Remove the front differential mounting bolts using a 15mm & 18mm socket. (See Photo # 9) Remove the front differential.
11. It will be necessary to cut the driver side frame rail where the OEM rear cross member was located. Measure toward the frame 3.5" & cut using a reciprocating saw or similar tool. (See Photo # 10) **Note:** It will be necessary to grind the forward lip on the frame for clearance of the supplied CV axle spacers. (See Arrow in Photo # 10)
12. It will be necessary to modify the passenger side differential pad for clearance. Measure from the backside of the differential mount bolt location toward the rear of the pad. Mark a line at 5/8" & cut using a reciprocating saw or similar tool. (See Photo # 11)
13. Install the new Skyjacker driver & passenger differential brackets using the OEM hardware. Be sure to install so the tallest portion of the new bracket is towards the front of the vehicle. Install the front differential using the supplied 9/16" x 2" coarse thread bolts, washers, & nuts on the passenger side & the 1/2" x 2" fine thread bolts, washers, & nuts on the driver side. Be sure to use the supplied square shim under the passenger side differential pad where it was previously cut. (See Photo # 12) Reconnect the OEM front drive shaft.

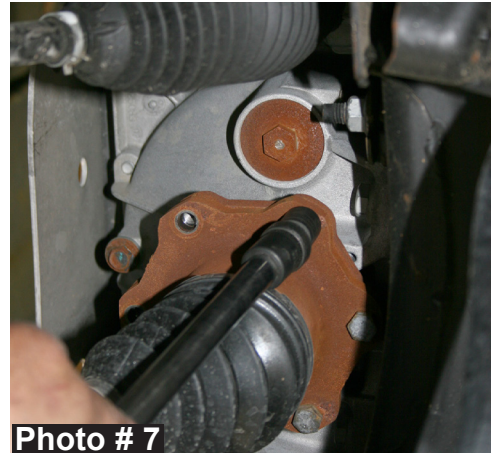

Photo # 7

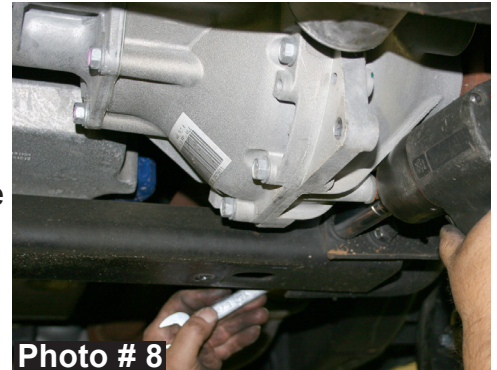

Photo # 8

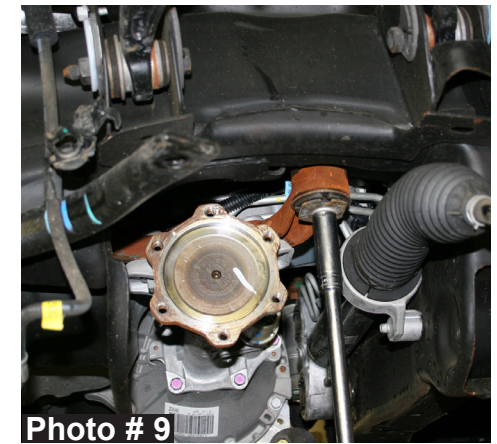

Photo # 9

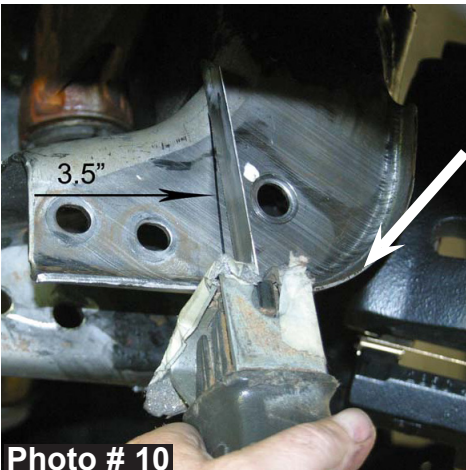

Photo # 10



Photo # 11

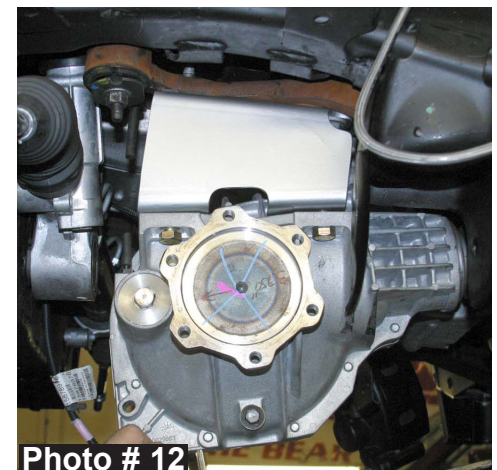

Photo # 12

14. Install the new Skyjacker rear cross member using the supplied 5/8 x 5 1/2" fine thread bolts, washers, & nuts. (See Photo # 13)

15. **Note:** It will be necessary to to grind the inside lower corners of the OEM cross member for proper fitment of the new Skyjacker front cross member. (See Arrows Photo # 14) Install the new Skyjacker front cross member using the supplied 5/8" x 4 1/2" fine thread bolts, washers, & nuts. (See Photo # 15)

16. Install the new Skyjacker anti torque arm using the supplied bushing & sleeve in the eye of the new anti torque arm. Attach the eye of the new anti torque arm assembly the new Skyjacker front cross member using the supplied 1/2" x 2 1/2" fine thread bolt, washers, & nut. Attach the lower ear to the front differential using the supplied 9/16" x 2 1/2" fine thread bolt, washers, & nut. (See Arrow Photo # 15)

17. Install the new Skyjacker front differential skid plate to the new front & rear cross members using the supplied 5/16" x 1" bolts, washers, & nuts. (See Photo # 16)

18. Install the OEM A-arms to the new Skyjacker cross members using the OEM hardware.

19. Remove the OEM hub bearing assemblies from the OEM steering knuckles using a 15mm socket. Install the OEM hub bearing assemblies to the new Skyjacker steering knuckles using the OEM hardware. (See Photo # 17)

20. Install the new Skyjacker strut spacers on the top of each OEM strut using the OEM hardware & 18mm wrench. (See Photo # 18)

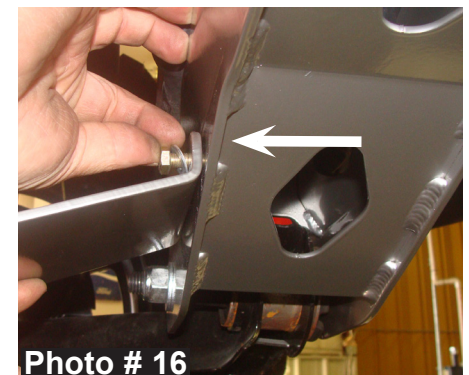
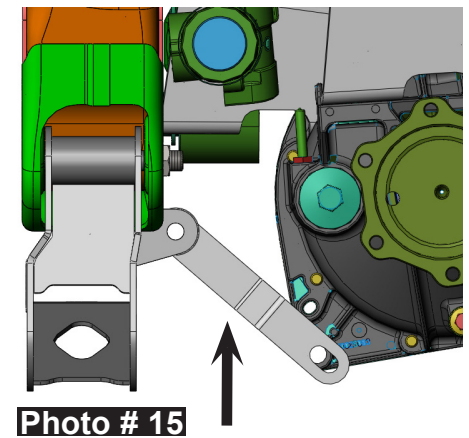
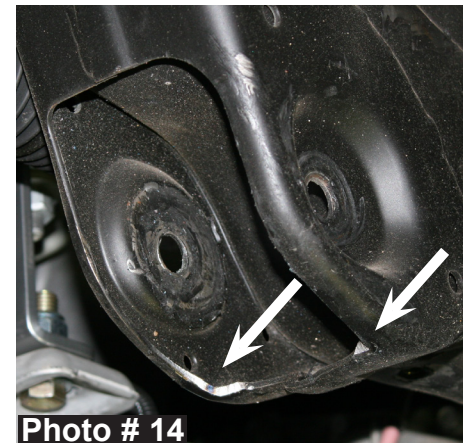

21. Install the strut assembly using the OEM lower bolts & the supplied 10mm nuts for the new upper strut spacer. (See Photo # 19 & # 20)

22. Install the new Skyjacker steering knuckles to the upper & lower A-arms using the OEM hardware. Install the OEM CV axles using the new Skyjacker CV axle spacers. Install using the supplied 10mm x 70 mm bolts & thread locking compound. (See Photo # 21)

23. Attach the OEM ABS lines to the side of the new Skyjacker steering knuckles using the supplied cable clamps & 6mm x 12mm bolts.

24. Install the new Skyjacker ABS line brackets using the supplied 5/16" x 1" fine thread bolts, washers, & nuts. (See Photo # 22)  
Install the new Skyjacker brake lines using the supplied instruction sheet.

25. In order to maintain OEM alignment specifications, the OEM inner & outer tie rods must be cut to obtain proper toe in. Remove the OEM outer tie rods from the OEM inner tie rods. Leaving the OEM jam nuts screwed onto the OEM inner tie rods, measure 1/2" from the ends of the OEM inner tie rods & make a mark. Measure 1/2" from the ends of the OEM outer tie rods & make a mark. Using a cut-off wheel or similar tool, cut along these marks. Unscrew the OEM jam nuts to chase the threads of the OEM inner tie rods. Reinstall the OEM outer tie rods to the OEM inner tie rods. The driver & passenger side OEM tie rods must be cut & adjusted equally to allow for proper toe in adjustment. (See Photo # 23)

26. Install the OEM outer tie rods to the new steering knuckles using the OEM hardware. Reinstall the OEM brake rotors & OEM brake calipers. **Note:** On some models it may be necessary to trim the OEM dust shield for proper brake caliper fitment. (See Photo # 24 & # 25)



Photo # 19



Photo # 20

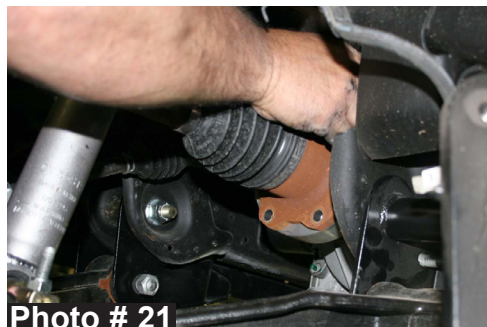

Photo # 21



Photo # 22

The length of both the inner & outer tie rods must be cut 1/2". Refer to arrows below.

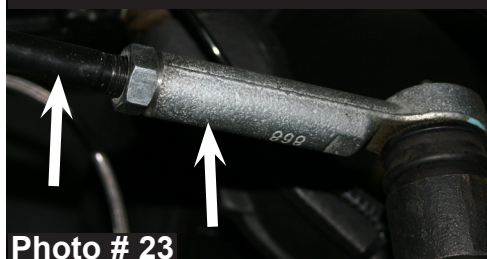

Photo # 23  
I-C766SP



Photo # 24

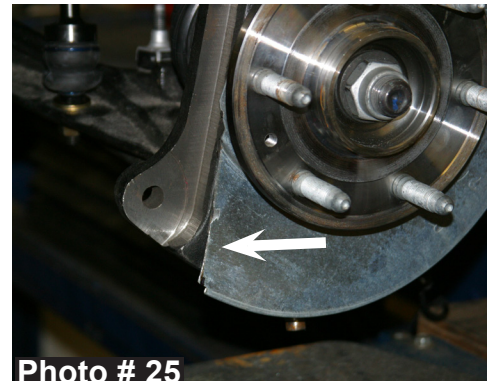
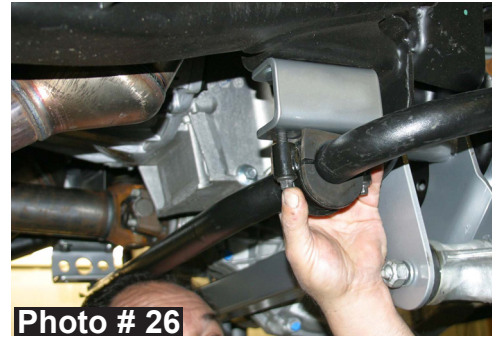
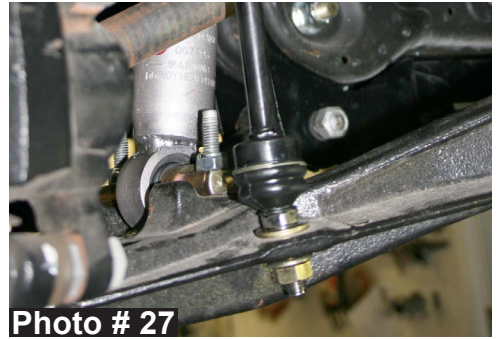

Photo # 25

27. Reinstall the OEM sway bar using the new Skyjacker drop brackets. The new brackets will install between the OEM sway bar & the OEM mount on the frame using the supplied 10mm x 30mm bolts, washers, & nuts. (See Photo # 26) Install the new Skyjacker sway bar end links. Be sure to install the new end link with the pivoting end at the A-arm. The gold washer should be on top of the A-arm, with the nut on the bottom. (See Photo # 27)



28. **Pick-Up Models:** Block the front tires / wheels, raise the rear of the vehicle, & properly support the frame using jack stands. Remove the OEM rear shocks using a 21mm socket & OEM U-bolts. Support the rear differential & install the new Skyjacker 4.5" rear lift blocks (thick end towards the rear) along with the new Skyjacker U-bolts. (See Photo # 28) If installing Skyjacker Softride rear leaf springs, simply remove the OEM leaf spring & replace. **Note:** If changing rear leaf springs, it will be necessary to lower the gas tank to gain access to the forward leaf spring bolt. **Note:** If your model is equipped with rear ABS lines, remove the OEM ABS lines from the plastic connectors on the frame & attach the OEM ABS lines to the outside of the new U-bolts using the supplied plastic ties. (See Photo # 29)



29. Lower the rear of the vehicle to the ground & proceed to Step # 44.

30. **SUV Models:** Block the front tires / wheels, raise the rear of the vehicle, & properly support the frame using jack stands. Remove the OEM rear shocks using a 21mm socket. Disconnect the OEM rear sway bar end links. (See Photo # 30)



31. Loosen the OEM lower & upper control arm bolts using a 21mm socket. (See Photo # 31)

32. Disconnect the OEM emergency brake cable from the driver side axle & passenger side frame using a 13mm socket. Disconnect the OEM brake line from the center of the axle.

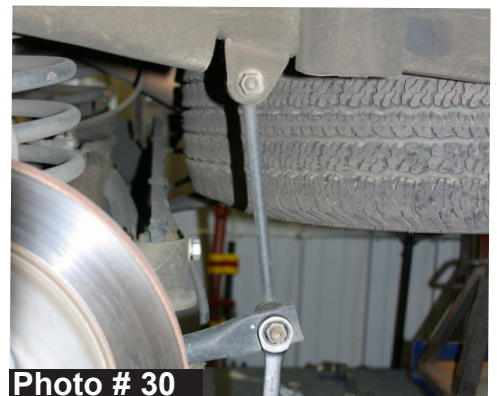
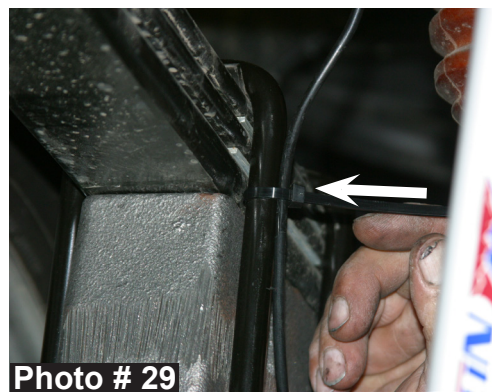

33. Lower the axle & remove the OEM coil springs. Be sure to retain the OEM upper & lower rubber isolator pads. (See Photo # 32)
34. Disconnect the OEM upper & lower control arms from frame rail. Only remove one side at a time so the axle does not move. Install the new Skyjacker upper / lower arm relocation bracket .

**Note: On the driver side only, be sure to install the supplied anti-crush sleeve into the OEM upper control arm position. (The sleeve is welded to the new Skyjacker bracket on the passenger side).**

35. Install the new Skyjacker upper / lower arm relocation brackets using the OEM hardware in the OEM locations. Attach the upper arms to the new Skyjacker brackets using the supplied 9/16" x 3 1/2" fine thread bolts, washers, & nuts. Attach the lower control arms to the new Skyjacker brackets using the supplied 9/16" x 4" fine thread bolts, washers, & nuts. (See Photo # 33) Be sure to install the supplied 1/2" x 1 1/4" fine thread bolt, washers, & nut into the bottom of each new bracket. The bolt will line up with the OEM hole in the bottom of the frame. (See Arrow in Photo # 34)

36. Loosen the OEM track bar mount bolt on the differential using a 21mm socket. Remove the OEM track bar bolt from the frame.
37. Install the new Skyjacker track bar bracket by sliding it into the OEM bracket. Install using the supplied 9/16" x 3 1/2" fine thread bolts, washers, & nut in the OEM bolt hole.

38. It will be necessary to drill a new hole through the back of the OEM bracket into the new Skyjacker bracket. It is recommended to first drill a small pilot hole, then drill using a 9/16" drill bit.

39. Once drilled, install the supplied 9/16" x 1 1/2" fine thread bolt, washers, & nut. (See Photo # 35)
40. Attach the rearward hole of the new Skyjacker bump stop brackets to the OEM mounting holes on the axle using the supplied 7/16" x 1" fine thread bolts, washers, & nuts. To access the front mounting hole, it will be necessary to lower the bottom control arm out of the way. (See Photo # 36)

41. Mark & drill the front hole using a 29/64" drill bit. Once drilled, install the supplied 7/16" x 1" fine thread bolts, washers, & nuts.

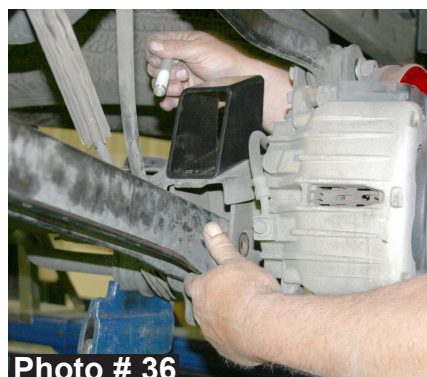
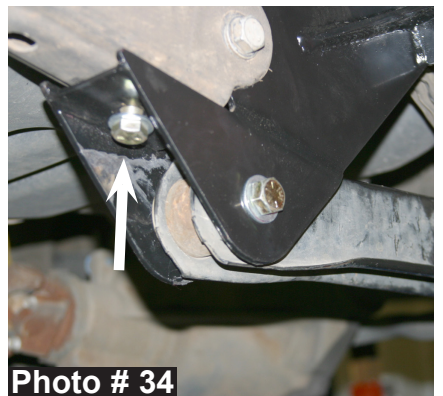
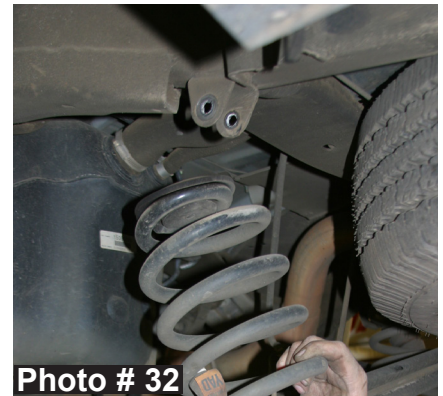

42. Install the new Skyjacker coil springs using the OEM upper & lower rubber isolator pads. (See Photo # 37) Once installed, carefully load the rear suspension & attach the OEM rear track bar to the new Skyjacker bracket using the OEM hardware.
43. Insert the supplied 5/8" polyurethane hourglass bushings into each end of the new Skyjacker sway bar end links. Insert the supplied 1/2" x 1 1/2" sleeves into each new bushing. Attach the new sway bar end links to the OEM mounts using the supplied 1/2" x 3" fine thread bolts, washers, & nuts. (See Photo # 38)
44. Install the new Skyjacker rear brake line bracket to the rear differential using the OEM hardware. Place the OEM rear brake line bracket on top of the new rear brake line bracket. Attach the OEM rear brake line bracket to the passenger side mounting location of the new rear brake line bracket using the supplied 5/16" x 1" fine thread bolt, washers, & nut. (See Photo # 39)  
**Note:** In order to prevent contact between the OEM rear hard brake lines & the new rear brake line bracket, it may be necessary to slightly bend the OEM rear hard brake lines for clearance.
45. Lower the rear of the vehicle to the ground & install the new Skyjacker rear shocks.

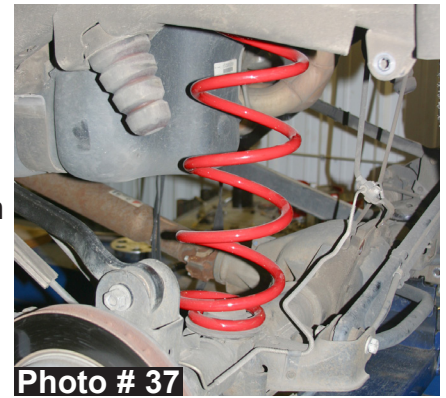

## **FINAL NOTES:**

- After the installation is complete, double check that all nuts & bolts are tight. Refer to the following chart for the proper torque specifications. (Do not retighten nuts & bolts where thread lock compound was used.)
- With the vehicle placed on the ground, cycle the steering lock to lock & inspect the steering, suspension, brake lines, front & rear drivelines, fuel lines, & wiring harnesses for proper operation, tightness, & adequate clearance.
- Have the headlights readjusted to the proper settings.
- Have a qualified alignment center align the vehicle to the OEM specifications.
- After the first 100 miles, check all of the hardware for the proper torque & periodically thereafter.

<b>TORQUE SPECIFICATIONS</b>					
<b>INCH SYSTEM</b>			<b>METRIC SYSTEM</b>		
<b>Bolt Size</b>	<b>Grade 5</b>	<b>Grade 8</b>	<b>Bolt Size</b>	<b>Class 8.8</b>	<b>Class 10.9</b>
5/16	15 FT LB	20 FT LB	6MM	5 FT LB	9 FT LB
3/8	30 FT LB	35 FT LB	8MM	18 FT LB	23 FT LB
7/16	45 FT LB	60 FT LB	10MM	32 FT LB	45 FT LB
1/2	65 FT LB	90 FT LB	12MM	55 FT LB	75 FT LB
9/16	95 FT LB	130 FTLB	14MM	85 FT LB	120 FT LB
5/8	135 FT LB	175 FT LB	16MM	130 FT LB	165 FT LB
3/4	185 FT LB	280 FTLB	18MM	170 FT LB	240 FT LB

**\*The above specifications are not to be used when bolt is being installed with a bushing.**

**Seat Belts Save Lives, Please Wear Your Seat Belt.**