

FRONT U-BOLT INSTALLATION KIT, TRANSFER CASE LOWERING AND CV U-JOINT MODIFICATION INSTRUCTION

Please read instructions before beginning installation.

This system contains no hardware for modifying or relocating the suspensions compression travel bump stops. Generally, bump stop modification is not required except for competition styled offroading. For severe offroading, extension travel limiting straps are recommended.

With the installation of all lift kits and larger tires it is important to check the condition of your steering stabilizer. If the stabilizer is worn or is leaking it should be replaced. Steering stabilizers are designed to restrain "bump steering" and front end vibration, giving added life to tires, ball joints, and other steering components. A multiple stabilizer kit is recommended for vehicles equipped with a snow plow, winch, or larger tires.

U BOLT INSTALLATION INSTRUCTIONS

- Step 1.** Remove 8 nuts from front u-bolts which attach axle housing to spring. Remove the u-bolts. Remove shock absorbers.
- Step 2.** Raise front of vehicle with a hydraulic bumper jack or other suitable equipment, until spring has cleared spring pad by approximately 4 1/2".
- Step 3.** Remove front and rear spring eye bolts and remove spring from vehicle.
- Step 4.** Install new springs (bushings and sleeves as applicable) with larger eye facing towards the front of the vehicle with the arch down.
- Step 5.** Lower jack until spring seats on spring pad with spring aligning pin in spring pad whole.
- Step 6.** Install four new u-bolts and install nylon locking nuts provided in the kit. Torque nuts to 120 ft./lbs. Torque evenly 5-10 lbs at a time, alternating from side to side.
- Step 7.** Install new shocks.

TRANSFER CASE LOWERING INSTRUCTIONS

For 1980 and later model years on 4" and 6" lifts, the transfer case is lowered by using stock mounting hardware on transfer case cross-member (see figure and pictures above).

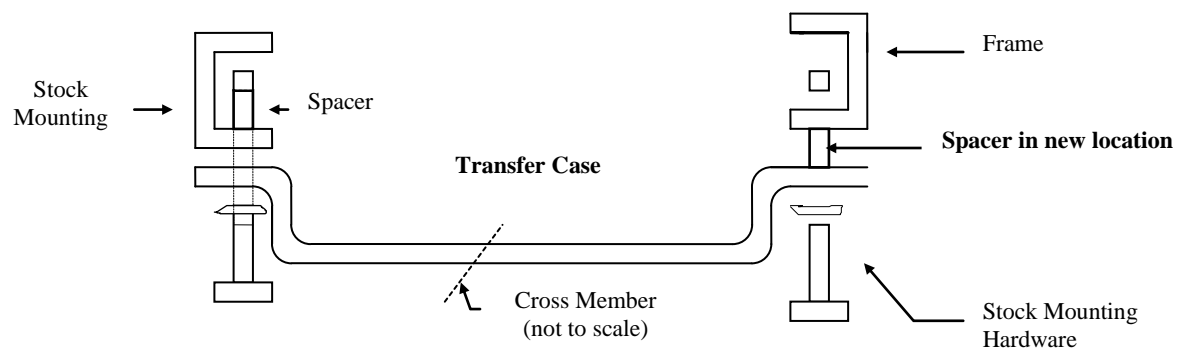

The stock hardware may be above or below cross member as shown below



- Step 1.** Place floor jack under transfer case cross-member, raise jack until it applies pressure to the cross-member. Remove stock mounting hardware.
- Step 2.** Lower floor jack until there is enough space between the cross-member and the frame to install stock spacer and mounting hardware per the diagram. Tighten all hardware.

FRONT CONSTANT VELOCITY U-JOINT STOP MODIFICATION INSTRUCTIONS

The stops on the front cv u-joint and the stops on the front drive shaft must be modified to obtain maximum suspension travel on all 4" and 6" lift systems (see diagram above). These stops are designed to prevent the drive shaft from contacting the road surface in the event of a u-joint failure at the front end housing.

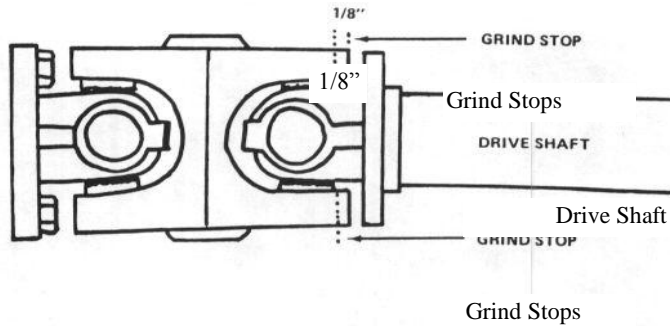

- Step 1.** Remove the front drive shaft assembly from the vehicle. Use a grinder or other suitable tool and remove the amount of material needed to gain ample u-joint clearance at the drive shaft stop. (Remove as little material as possible).
- Step 2.** With the grinding completed, reinstall the drive shaft and check the stop clearance by turning the drive shaft.

BRAKE LINE BRACKET EXTENSION

On all 4" and 6" lifted systems you must relocate the brake lines using the brake line bracket extensions the are included in the kit for the front leaf springs. If new lines are desired, Rough Country does carry extended brake lines.

FRONT BRAKE LINES

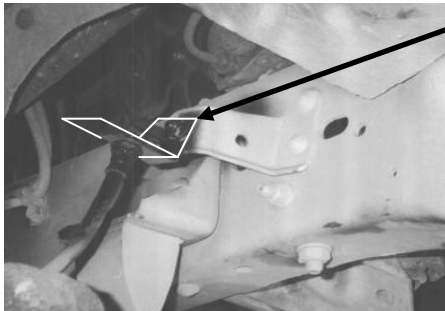

Unbolt brake line from mount and bend steel line from frame to meet rubber line as shown in the picture Mount L bracket to frame. **NOTE Please bleed brake system before driving.**

Unbolt brake line and mount new bracket to the existing mount. Brake line will be relocated to larger hole.

REAR BRAKE LINE



PRODUCT USE INFORMATION

As a general rule, the taller a vehicle is, the easier it will roll. Offset, as much as possible, what is lost in rollover resistance by increasing tire track width. In other words, go "wide" as you go "tall". Many sportsmen remove their mud tires after hunting season and install ones more appropriate for street driving; always use as wide a tire and wheel combination as possible to enhance vehicle stability.

We strongly recommend, because of rollover possibility, that the vehicle be equipped with a functional roll-bar and cage system. Seat belts and shoulder harnesses should be worn at all times. Avoid situations where a side rollover may occur.

Generally, braking performance and capability are decreased when significantly larger/heavier tires and wheels are used. Take this into consideration while driving.

Do not add, alter, or fabricate any factory or aftermarket parts to increase vehicle height over the intended height of the Rough Country product purchased. Mixing component brands is not recommended.

Rough Country makes no claims regarding lifting devices and excludes any and all implied claims. We will not be responsible for any product that is altered

MAINTENANCE INFORMATION

It is the ultimate buyers responsibility to have all bolts/nuts checked for tightness after the first 100 miles and then every 1000 miles. Wheel alignment steering system, suspension and driveline systems must be inspected by a qualified professional mechanic at least every 3000 miles.