

INSTALLATION INSTRUCTIONS
372981/372983/372984/4446B/4446C/4446PS SIDE BAR
08-09 TOYOTA HIGHLANDER

Part list:

ITEM	Qty	DESCRIPTION
1	1 SET	SIDE BAR TUBE
2	1 SET	BRACKETS
2.1	1 SET	FRONT BRACKETS
2.2	1 SET	REAR BRACKETS
2.3	4 PC	AUXILIARY BRACKETS
2.4	2 PC	BIG "T" BRACKET
2.5	4 PC	SMALL "T" BRACKET
2.6	4 PC	NUT BRACKET
2.7	1 SET	HARDWARE KIT
2.7.1	4 PC	3/8 x 1 1/4" ZINC PLATED HEX HEAD BOLT
2.7.2	6 PC	3/8" ZINC PLATED FLAT WASHER
2.7.3	6 PC	3/8" ZINC PLATED LOCK WASHER
2.7.4	8 PC	1/4" ZINC PLATED FLAT WASHER
2.7.5	8 PC	1/4" ZINC PLATED LOCK WASHER
2.7.6	8 PC	1/4" ZINC PLATED NUT
2.7.7	4 PC	1/4x1" ZINC PLATED HEX HEAD BOLT
2.7.8	8 PC	3/8x1 1/4" BLACK HEX HEAD BOLT
2.7.9	8 PC	3/8" BLACK FLAT WASHER
2.7.10	8 PC	3/8" BLACK LOCK WASHER
2.7.11	2 PC	3/8" ZINC PLATED NUT

Tools required:

DESCRIPTION	Qty
10mm. SOCKET	1
9/16" SOCKET	1
7/16" SOCKET	1
FLAT SCREW DRIVER	1
RATCHET EXTENSION	1
RATCHET	1

Aproximated installation time: 30 min.

Img. 1

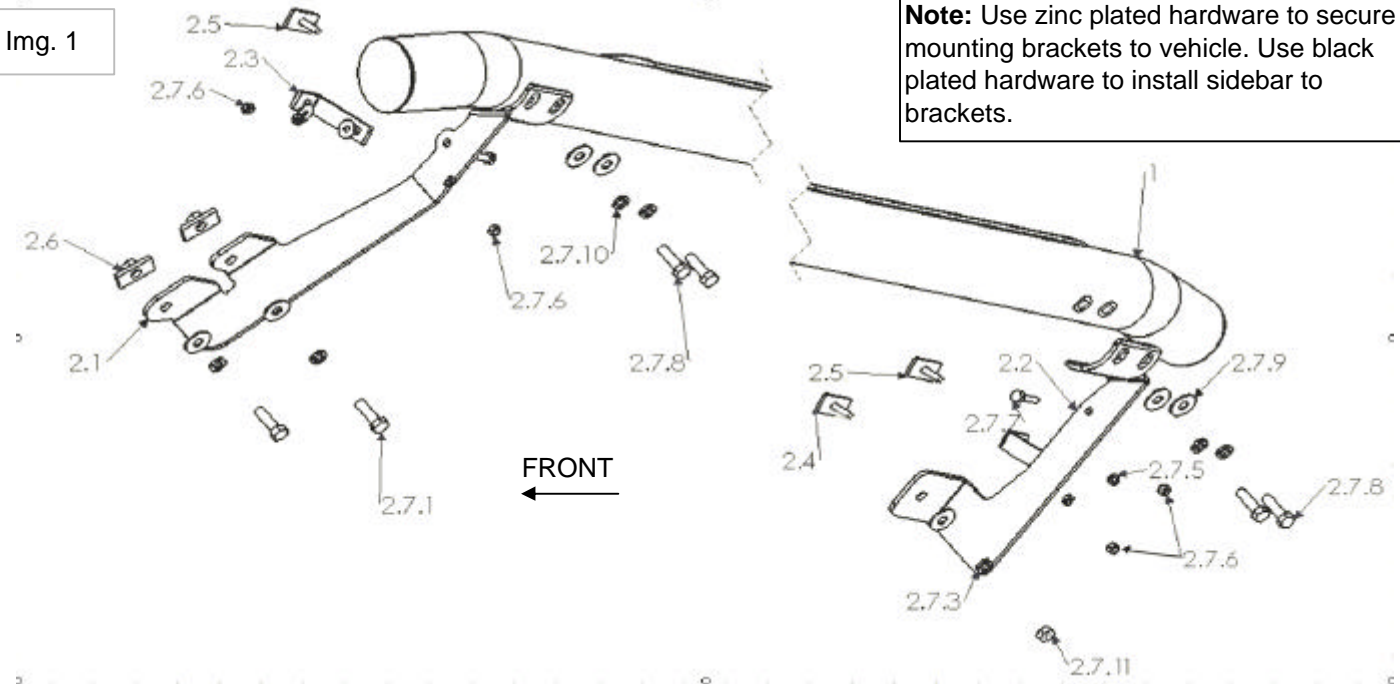

Cleaning and care instructions:

Protect the finish with a non-abrasive automotive wax, (e.g. Pure Carnauba) on a regular basis. The use of any soap, polish, or wax that contains an abrasive is detrimental to the finish, as the compounds scratch the finish and cause.

Design:

Quality:

INSTALLATION INSTRUCTIONS
372981/372983/372984/4445B/4445C/4445PS SIDE BAR
08-09 TOYOTA HIGHLANDER

1. Carefully read and understand instructions before start installation. If You can not find all the listed parts, please stop installation and call to your distributor to get the missing pieces.

2. Locate at front underneath of vehicle the bolt and retainer shown in image 2 (shown driver's side). Remove existing bolt and plastic retainer, identify the larger hole and expose the smallest hole behind the plastic cover.

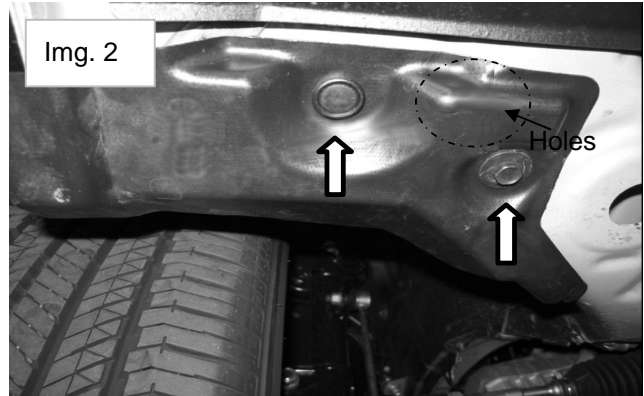

3. To install front bracket, introduce into larger hole (2) nut bracket, one of them should reach the smallest hole, the nuts must coincide with the smallest and larger holes, secure front bracket using (2) 3/8x1 1/4" hex bolt (2) 3/8" flat washer (2) 3/8" lock washer. **Image 1 & 3**

4. Underneath front/rear door there are existing holes cover with plastic grommets, remove the nearest grommet to the front mudguard, then introduce (1) small "T" bracket, place auxiliary bracket and secure using (1) 1/4" hex nut (1) 1/4" flat and lock washers. Secure the other end to the auxiliary bracket to the front/rear bracket using (1) 1/4x1" hex bolt (1) 1/4" flat and lock washers, (1) 1/4" hex nut. Image. 3

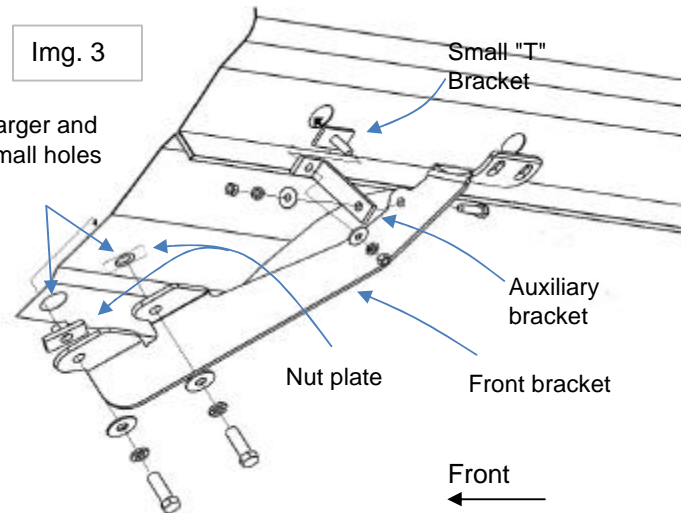

5. To install rear bracket, locate existing oval hole then introduce big "T" bracket. Place rear bracket and secure using (1) 3/8" hex nut (1) 3/8" flat and lock washer. Image 4.

6. To install rear auxiliary bracket follow the same procedure in step 4 and watch image 4.

7. Place sidebar to the brackets, use (4) 3/8x1 1/4" hex head bolt (4) 3/8" flat and lock washers. Image 5

8 Fill out your warranty card and place it inside your vehicle.

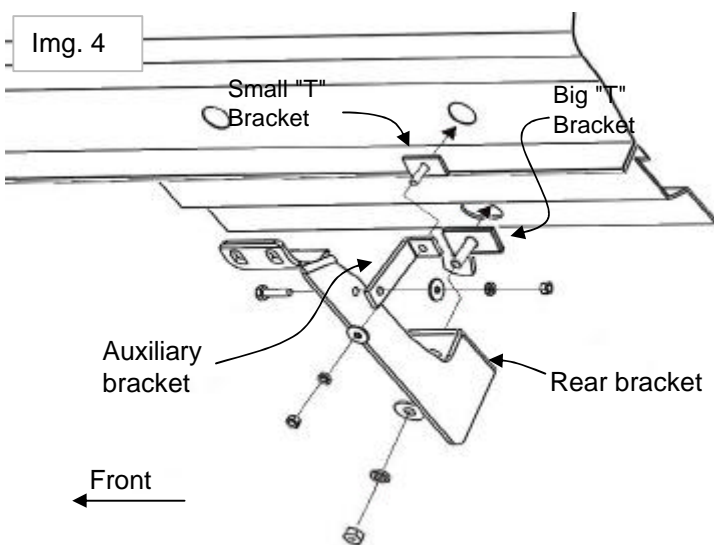
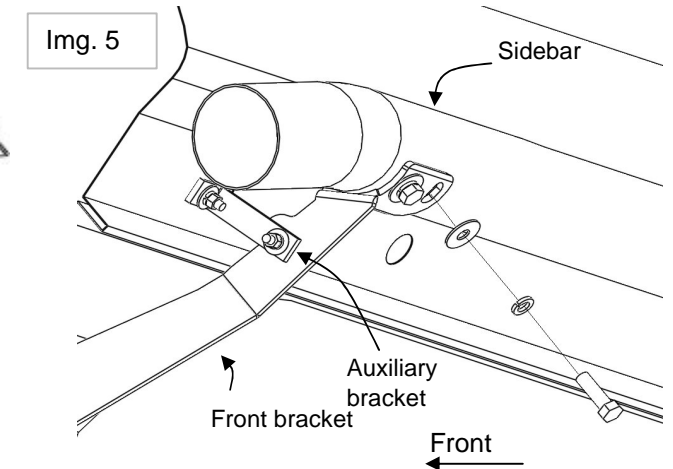

Cleaning and care instructions:

Protect the finish with a non-abrasive automotive wax, (e.g. Pure Carnauba) on a regular basis. The use of any soap, polish, or wax that contains an abrasive is detrimental to the finish, as the compounds scratch the finish and cause.

Design:

Quality: