



Figure 1: 1970 Chevelle features our Ackermann and Bump Steer kit [picture by Alan Miller]

Congratulations on the purchase of your new Speedtech Performance Ackermann and bump steer adjustment kit. Use only approved, appropriately rated jack and jack stands, and take all required safety precautions to complete the job safely and correctly. If you have any uncertainties, seek the assistance of a highly qualified workshop.

Read and understand all instructions thoroughly before you begin. Your main assembly and setup of your new Ackermann and bump steer can be done in a home garage with hand tools.

Speedtech enjoys seeing the progress our customers are making as they work through their builds. Join the group Team Speedtech on Facebook and share your pictures and story.

Speedtech Performance wishes you the best with your project!

TABLE OF CONTENTS

1.0	GENERAL INFORMATION.....	4
1.1	THIS GUIDE	4
1.2	OVERVIEW	4
1.3	TOOLS	4
2.0	CHECK IN PARTS AND HARDWARE.....	5
2.1	CHECKING IN THE ORDER	5
2.2	CHECK IN TABLE	5
3.0	GETTING STARTED / INSTALLATION	6
3.1	LEVELING AND SUPPORT	6
3.2	STEERING ARMS / LINKAGE REMOVAL.....	6
3.3	JAM NUTS.....	6
3.4	INSTALLING TO SLEEVES.....	7
3.5	SHOULDER BOLT	7
3.6	REPEAT	7
4.0	ALIGNMENT / SET UP	8
4.1	ALIGNMENT	8
4.2	SETTING BUMP STEER	9
5.0	FINAL STEPS.....	10
6.0	CONGRATULATIONS	10

1.0 GENERAL INFORMATION

[Back to Table of Contents](#)

1.1 THIS GUIDE

Thank you for purchasing your new Speedtech Performance Extreme enhanced Ackermann and bump steer adjustment kit. Read all instructions thoroughly before beginning, and take all required safety precautions to do the job carefully and correctly.

The following instructions are intended for professional installers and are guidelines only. Speedtech Performance assumes no responsibility for the installation of any of its products installed by others. All products are intended to be installed by qualified professionals. However, if you have uncertainty, seek the assistance of a highly qualified workshop.

1.2 OVERVIEW

These instructions outline the enhanced Ackermann and bump-steer adjustment kit to be installed with the Speedtech Performance forged tall spindle. Photos in the instruction process may vary slightly from your exact operation.

1.3 TOOLS

Installation of the Speedtech Performance-enhanced Ackermann and bump-steer adjustment kit can be done on the floor with simple hand tools.

Additional things to have before you start:

- Wrench
- Drill / Bits

2.0 CHECK IN PARTS AND HARDWARE

[Back to Table of Contents](#)

2.1 CHECKING IN THE ORDER

Check in your order as soon as possible. To check the order, Speedtech has provided a table that can be used as a checklist, as displayed in Figure 2. All bolts and nuts are NF unless otherwise noted. Hardware comes in several boxes. If you discover anything missing from your order, call your authorized dealer as soon as possible.

2.2 CHECK IN TABLE

X	#	Description	Size
	2	Billet Long Tie Rod Sleeves	
	2	Heim Joints	
	2	Shoulder Bolts	5/8"
	2	Nylock Nuts	
	2	RHT Jam Nuts	
	2	LHT Jam Nuts	
	1	Pkg. Tall Shims	5/8"
	1	Pkg. Short Shims	5/8"

Check the table with amounts, descriptions, and sizes.

NOTE: There may be some extra hardware that was packaged but is not accounted for in the checklist. The hardware kits are designed to fit multiple products; hence, there may be a surplus of supplies.

3.0 GETTING STARTED / INSTALLATION

[Back to Table of Contents](#)

3.1 LEVELING AND SUPPORT

WARNING: The vehicle should be on a level surface before you start.

First, jack up and properly support the vehicle's frame. The suspension should be at drive height when installing the bar. If the car is on a lift and the suspension is in droop when you install the kit, it will not line up properly when back on the ground. The sway bar brackets will all need to be test-fitted into place before final installation to ensure proper bar alignment and prevent binding during suspension travel.

The enhanced Ackermann and bump steer adjustment kit gets installed after your Speedtech Performance forged tall spindle (see spindle instructions).

3.2 STEERING ARMS / LINKAGE REMOVAL

Install the steering arms with the tie rod ends pointing outward (A). Remove the old outer tie rods and adjusting sleeves from the steering linkage. Do not remove the inner tie rods from the center link unless they need to be replaced.

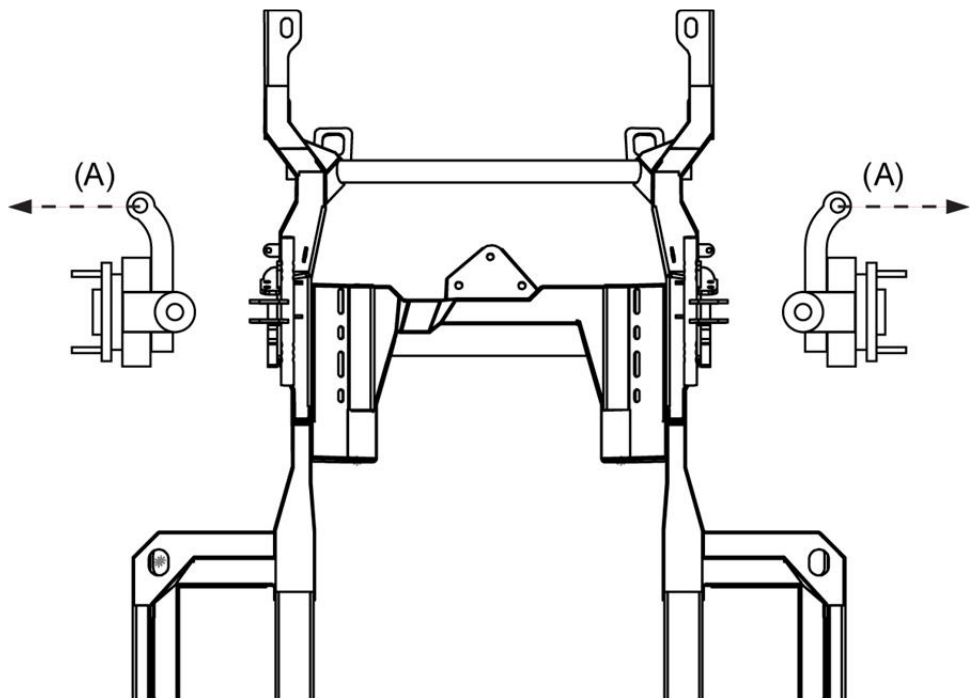

Figure 3: Steering arms/linkage removal

3.3 JAM NUTS

Thread a jam nut several threads onto both the rod end and the inner tie rod. Pay close attention to using the correct nut thread direction in the appropriate corresponding locations.

3.4 INSTALLING TO SLEEVES

Apply anti-seize to the threads on both ends of the adjuster sleeves. Thread the machined end of one adjuster sleeve (see figure 4) a couple of times onto one inner tie rod. Thread one rod end the same number of threads into the other end of the adjuster. Holding the rod end steady, use the other hand to rotate the adjuster sleeve so it simultaneously tightens down both sides by equal amounts until it aligns with the spindle steering arm, with the wheel pointed straight forward.

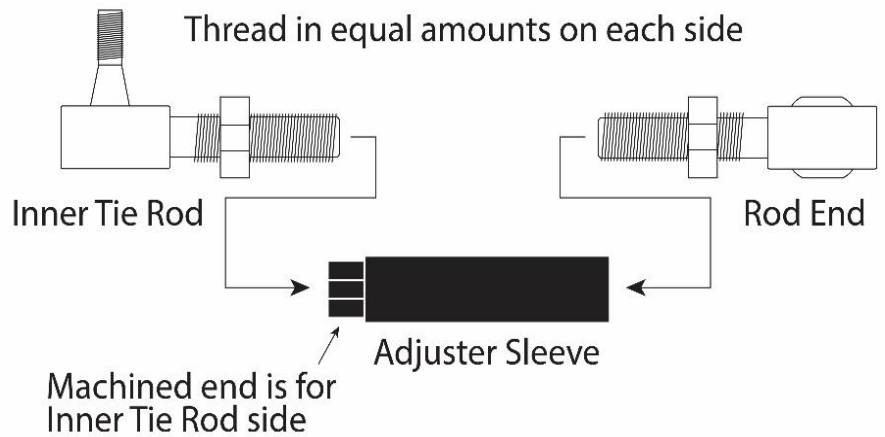

Figure 4: Threading equal amounts on each side

3.5 SHOULDER BOLT

Install the shims, shoulder bolt, and nylock nut as seen in Figure 5. With the suspension mocked up at ride height, if necessary, adjust the shims to position the tie rod assembly close to parallel with the ground. This will give you a good base bump steer setting to start with. Fingertighten the nylock nut; do not fully tighten it at this point.

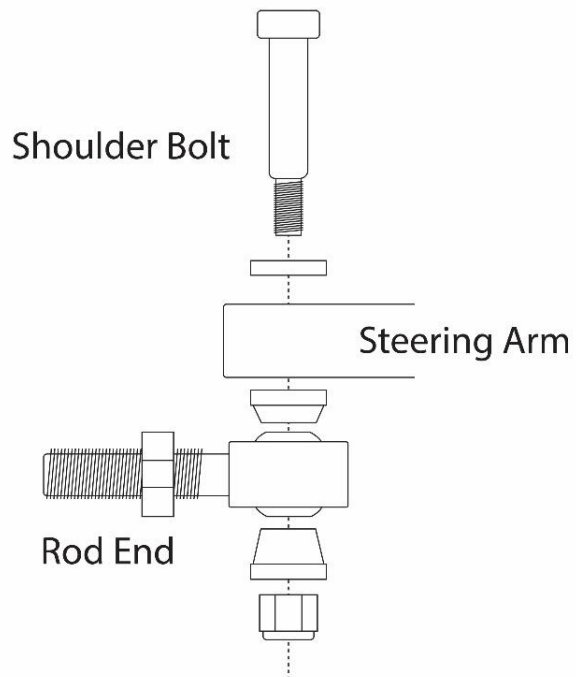

Figure 5: Installing the shoulder bolts, steering arms, and rod ends.

3.6 REPEAT

Repeat steps 3.2-3.5 on the other side of the car.

4.0 ALIGNMENT / SET UP

[Back to Table of Contents](#)

Using the center point of the frame as a reference, align the center link's midpoint with the vehicle's center. Now, with the suspension at ride height and the wheels and tires bolted in place, adjust each side's toe setting by turning the adjuster sleeves equally either forward or backward until the tires are facing forward. You can get the toe setting fairly close by adjusting the suspension until the distance between the same points on the front side of each tire equals the distance between the same points on the rear side of each tire, see (X) in figure 6. Adjust as needed until both front and rear measurements are near the same. When finished, snug all four jam nuts finger tight. This will be close enough to drive the car onto a trailer to take to a competent alignment shop.

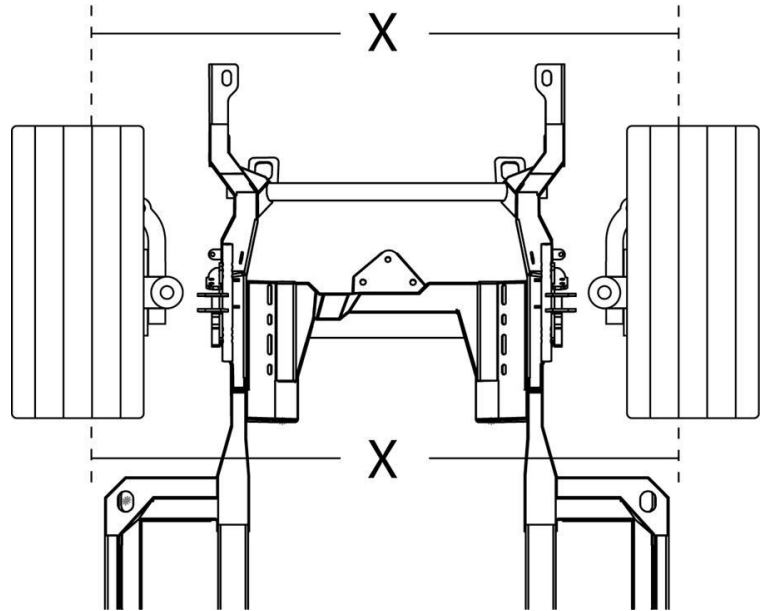

Figure 6: Toe Setting

4.1 ALIGNMENT

Bring the car to a reputable alignment shop familiar with performance alignment settings and how they relate to one another. They must be familiar with, but not limited to, the following: the caster, camber gain, toe settings for specific driving or racing conditions, bump steer adjustment, etc.

When the alignment is finalized, the alignment technician will tighten the tie-rod adjuster jam nuts.

The following are the specifications needed for alignment, unless noted otherwise.

Daily Driving, Street Performance Specifications

Driver Side	Passenger Side
4 Degrees positive Caster	4 ½ Degrees positive Caster
0 to ½ Degree negative Camber	0 to ½ Degree negative Camber
3/ 32 Total Toe-in	3/ 32 Total Toe-in

Aggressive Track Alignment Specifications

Driver Side	Passenger Side
5 ½ Degrees positive Caster	6 Degrees positive Caster
½ to 1 Degree negative Camber	½ to 1 Degree negative Camber
3/ 32 Total Toe-in	3/ 32 Total Toe-in

Original Alignment Specifications

****For reference purposes only. Do not use these specs.**

Driver Side	Passenger Side
½ Degree positive Caster	½ Degree positive Caster
¼ to ½ Degree negative Camber	¼ to ½ Degree negative Camber
1/8 Total Toe-in	1/8 Total Toe-in

Figure 7: Three charts depicting the alignment settings

4.2 SETTING BUMP STEER

With all other alignment specifications set, you can check and adjust your bump steer.

- First measure and record the distance from the center of the hub vertically to the fender. This will give you your ride height wheel position.
- Raise the car off the ground, while getting support on jack stands, and remove one wheel. Using a floor jack, raise the suspension to ride height while matching the measurement from the hub center to the fender. Using a bump steer gauge, find measurements at 2-3" of compression and 2-3" of rebound. If bump steer is more than roughly .015 (15 thousandths), return the suspension to ride height.
- Disconnect and remove the shoulder bolt at the tie rod end and rearrange the spacers as necessary, moving the rod end either closer to or further from the steering arm.
- Then, reassemble and remeasure. Additional shims not included in the kit may be required to minimize bump steer.
- Lastly, torque the nylock nut to 40 ft./lbs when finished. Be sure there are enough shims so that the nut makes contact with and tightens the rest of the assembly, and so that one-two threads are showing beyond the nut when finally torqued down.
- **NOTE!** You'll want to avoid static toe-in and bump-out. If your toe is set to toe in, then any amount of bump must be bump in. The same rule applies to toe-out (autocross setting): any bump must be a bump-out.
- After bump steer is in range, recheck the other alignment specs.
- Recheck the torque on all fasteners after 100 miles.

5.0 FINAL STEPS

[Back to Table of Contents](#)

Be sure that all measurements are correct and double-check that all components have proper clearance throughout your suspension's travel range. Torque all bolts to spec. Tighten all loose suspension bolts and double-check all bolts to ensure they are all tight. (It is recommended you fill all grease fittings at this time. Speedtech suggests using Permatex Ultra Slick Synthetic Grease, but any high-quality chassis grease will do. For your Sweet power rack-and-pinion, we recommend using Sweet or Jones-brand full synthetic power steering fluid for best performance and to avoid overheating standard-type fluids during performance driving.

This concludes the instructions for the enhanced Ackermann and bump steer adjustment kit.

6.0 CONGRATULATIONS

[Back to Table of Contents](#)

Congratulations on completing your project. We know you will get many years of enjoyment from it. Please join the group [Team Speedtech](#) on Facebook. Team Speedtech is a community of like-minded individuals using Speedtech Performance products. The Group's members include customers, our dealers, and factory employees - each with a passion for Pro Touring muscle cars. You can ask questions and get advice from the group members as well as share your experience. Within the group, we enjoy seeing the videos and pictures as your projects progress, so post up. We also encourage you to share pictures and videos of your finished projects out on the road, at the show & shine, on track, or however you get enjoyment from your ride, we want to see it!

Thank you for choosing Speedtech Performance! We know you have a choice, and we appreciate that you entrust us with your chassis and suspension needs for your custom muscle cars.

Speedtech Performance, LLC
4160 S. River Rd.
St George, UT, 84770
(435) 628-4300