

Technical Support Line: (952) 985-5675 Email: sales@QA1.net

INSTALLATION INSTRUCTIONS

QA1 P/N BAX106

'82-'92 F-Body Bump Steer Kit

TOOLS AND SUPPLIES REQUIRED

- Floor Jack
- Jack Stands
- Wrench Set
- Ratchet & Socket Set
- Measuring Tape

OVERVIEW OF BUMP-STEER

Definition of bump-steer: Bump-steer is a change in toe angle caused by the suspension moving up or down. Bump-steer is built into the geometry of the suspension and steering system and has nothing to do with turning the steering wheel. The effect of bump-steer is for the wheel to toe-in or toe-out when the suspension moves up or down. This toe change, or "steering" occurs any time the suspension moves, whether it is from body roll, brake-dive, or hitting a bump in the road. Bump steer is undesirable because the suspension is steering the car instead of the driver.

Cause of bump-steer: The front wheels do not move directly straight up or down when the car hits a bump. Instead, the wheel follows an arc, or curving path, that pushes the wheel slightly inward (towards the centerline of the car) or outward (away from the car) in response to vertical wheel movement. The outer tie-rod (which connects the steering rack to the wheel) also moves in-and-out in an arc as it moves up and down. If the rate which the outer tie-rod arcs in or out does not match the rate the wheel moves in or out, the wheel will be turned by the tie-rod. This is bump-steer.

The center point of the arc traveled by the wheel (known as the instant-center) is controlled by the location and angle of the moving suspension links. This point moves as the ride height changes. In contrast, the arc of the outer tie-rod is controlled by the position of the steering rack, which is fixed. In order to eliminate bump-steer, both the length and the center point of the two arcs must be the same. However, since the instant center moves with ride height, bump-steer cannot be eliminated throughout the entire range of suspension travel. Therefore, suspension designers concentrate on minimizing bump-steer within the range of movement closest to factory ride height. Changing the ride height or other suspension components may move the suspension outside this narrow "optimized" window.

To lessen or eliminate a bump-steer problem, you need to alter the height of the outer tie-rod relative to the steering rack. Small changes in this relationship can be made with offset rack bushings. Making big changes requires adjustable tie-rod ends, also known as a bump-steer kit.

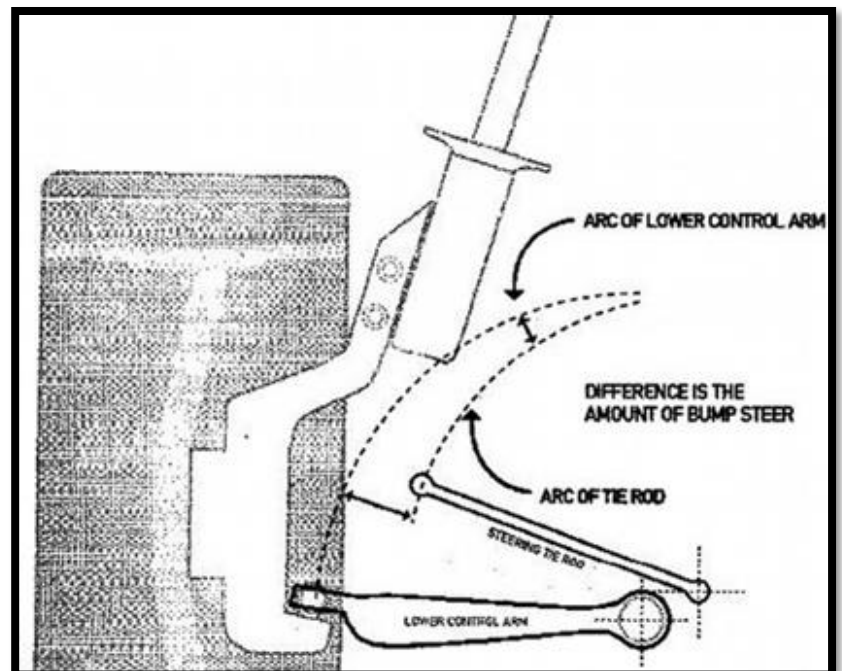

DISSASSEMBLY-

1. Raise the front of the vehicle and support it with jack stands on a stable surface.

PRE-INSTALLATION NOTE:

Measure the length of your current tie rods before removing them from the vehicle from the center of the pin in the spindle to a given point on the inner tie rod. This measurement will be used to adjust the new tie rod sleeves and return the toe close to its original position before a professional alignment is performed.



2. Loosen the left-hand threaded jam nut from the original inner tie rod.
3. Remove the stud from the spindle, allowing the tie rod to hang down and the original tie rod to be unthreaded (left-hand threads) from the inner tie rod.

BUMP STEER ASSEMBLY-

1. Thread the right-hand threaded jam nuts (#3) onto the right-hand threaded rod ends (#4). (Figure 1)
2. Thread the rod ends with jam nuts into the right-hand threaded end of the tie rod sleeves (#2) leaving only a couple threads visible under the head of the rod end. (Figure 2)
3. This bump steer kit comes with four different widths of spacers. Install one of the thickest spacers (#11) and two of the slightly thinner (#10) spacers onto the non-tapered side of the spindle stud (#5). (Figure 3)
4. Insert the non-tapered end of the spindle stud through the rod end, then the remaining spacers (one #9 and one #8) onto the stud before securing with the nylock nut (#12). (Figure 4)



Figure 1



Figure 2



Figure 3

NOTE:

The recommended orientation of spacers in step 3 are only a starting point. Adding or removing spacers from the stud between the fixed hex and rod end will change the tie rod angle, and therefore the bump steer. Unused spacers should be installed between the rod end (#4) and 5/8" nut (#12).



Figure 4

BALLOON #	ITEM #	DESCRIPTION	QTY.
1	JNL10S	JAM NUT, STEEL 5/8-18 LH	2
2	9033-537	SLEEVE, 1.125 HEX, ALUMINUM	2
3	JNR10S	JAM NUT, STEEL 5/8-18 RH	2
4	XMR10	ROD END (X) ENDURA ALLOY HT	2
5	9029-405	STUD, SPINDLE BUMP STEER	2
6	9005-243	WASHER, FLAT 7/16" SAE	2
7	9014-442	NUT, 7/16-20, NYLOCK	2
8	9033-212	SLEEVE, .63" ID X .875" X .060"	2
9	9033-211	SLEEVE, .63" ID X .875" X .100"	2
10	9033-210	SLEEVE, .63" ID X .875" X .190"	4
11	9033-209	SLEEVE, .63" ID X .875" X .280"	2
12	9014-323	NUT, NYLOCK JAM 5/8-18	2

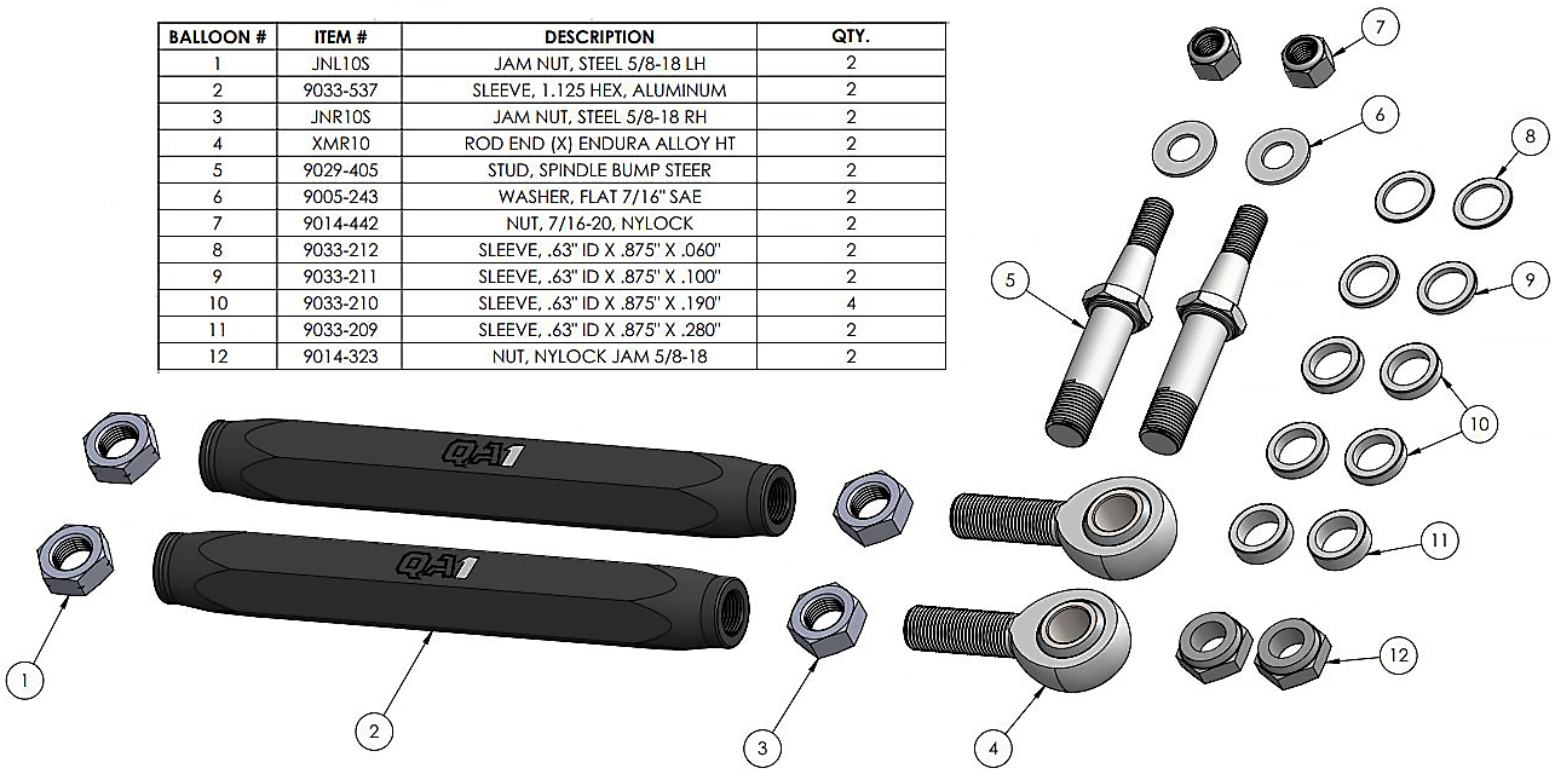

5. Thread the left-hand threaded jam nut (#1) onto the inner tie rod.
6. Thread the left-hand threaded end of the tie rod sleeve onto the left-hand threaded inner tie rod. (Figure 5) The tie rod sleeve should be threaded onto the inner tie rod until it matches the tie rod length taken before this installation. Ensure that there are 3-4 threads of the rod end showing with the tie rod at the measured length so that final adjustments can be made.
7. Insert the tapered end of the stud up through the bottom of the spindle steering arm before securing the stud with a 7/16" washer (#6) and a nyloc nut (#7). (Figure 6)
8. Holding the fixed hex on the spindle stud, torque the 7/16" nut on top of the assembly to 23 lb. ft. and the lower 5/8" nut to 36 lb. ft.



9. Double check the tie rod length against the pre-installation measurement before tightening the left and right hand jam nuts into the QA1 tie rod sleeve by holding the sleeve with a crescent or 1-1/16" wrench and a 15/16" wrench on the nuts.

A PROFESSIONAL ALIGNMENT IS RECOMMENDED BEFORE DRIVING THE VEHICLE



Technical Support Line: (952) 985-5675 Email: sales@QA1.net

READ ALL INSTRUCTIONS CAREFULLY AND THOROUGHLY PRIOR TO STARTING INSTALLATION. PRODUCTS THAT HAVE BEEN INSTALLED ARE NOT ELIGIBLE FOR RETURN. USE THE PROPER JACKING LOCATIONS. DEATH OR SERIOUS INJURY CAN RESULT IF INSTRUCTIONS ARE NOT CORRECTLY FOLLOWED. A GOOD CHASSIS MANUAL, AVAILABLE AT YOUR LOCAL PARTS STORE, MAY ALSO AID IN YOUR INSTALLATION.

• DISCLAIMER / WARRANTY •

QA1 WARRANTS THAT THE PRODUCTS WILL BE FREE FROM DEFECTS IN MATERIAL AND WORKMANSHIP FOR ONE YEAR FROM DATE OF SALE TO THE ORIGINAL PURCHASER. QA1 MAKES NO OTHER WARRANTY OF ANY KIND, EXPRESS OR IMPLIED. QA1 SHALL HAVE NO OBLIGATION UNDER THE FOREGOING WARRANTY WHERE THE DEFECT IS THE RESULT OF IMPROPER OR ABNORMAL USE, YOUR NEGLIGENCE, VEHICLE ACCIDENT, IMPROPER OR INCORRECT INSTALLATION OR MAINTENANCE, NOR WHEN THE PRODUCT HAS BEEN REPAIRED OR ALTERED IN ANY WAY. QA1'S LIABILITY IN THE CASE OF DEFECTIVE PRODUCTS SUBJECT TO THE FOREGOING WARRANTY SHALL BE LIMITED TO THE REPAIR OR REPLACEMENT, AT QA1'S OPTION, OF THE DEFECTIVE PRODUCTS.

THE USER UNDERSTANDS AND RECOGNIZES THAT RACING PARTS, SPECIALIZED STREET ROD EQUIPMENT, AND ALL PARTS AND SERVICES SOLD BY QA1 ARE EXPOSED TO MANY AND VARIED CONDITIONS DUE TO THE MANNER IN WHICH THEY ARE INSTALLED AND USED. QA1 SHALL BEAR NO LIABILITY FOR ANY LOSS, DAMAGE OR INJURY, EITHER TO A PERSON OR TO PROPERTY, RESULTING FROM THE INSTALLATION, DIRECT OR INDIRECT USE OF ANY QA1 PRODUCTS OR INABILITY BY THE BUYER TO DETERMINE PROPER USE OR APPLICATION OF QA1 PRODUCTS. WITH THE EXCEPTION OF THE LIMITED LIABILITY WARRANTY SET FORTH ABOVE, QA1 SHALL NOT BE LIABLE FOR ANY CLAIMS, DEMANDS, INJURIES, DAMAGES, ACTIONS, OR CAUSES OF ACTION WHATSOEVER TO BUYER ARISING OUT OF OR CONNECTED WITH THE USE OF ANY QA1 PRODUCTS. MOTORSPORTS ARE DANGEROUS; AS SUCH, NO WARRANTY OR REPRESENTATION IS MADE AS TO THE PRODUCT'S ABILITY TO PROTECT THE USER FROM INJURY OR DEATH. THE USER ASSUMES THAT RISK!

DEDICATED TECH SUPPORT

QA1 is dedicated to providing quality support and instructions. We employ passionate racers and car enthusiasts that know our products and the industry to better serve you.

CHECK US OUT ON YOUTUBE!



- Frequently Asked Questions
- Quick Tips
- Install Information
- Tuning and Repair Guides
- Other Technical Information



- [linkedin.com/company/qa1](https://www.linkedin.com/company/qa1)
- [instagram.com/qa1motorsports](https://www.instagram.com/qa1motorsports)
- [facebook.com/qa1motorsports](https://www.facebook.com/qa1motorsports)

youtube.com/qa1tech

www.qa1.net/tech