



These instructions can be found in color and expandable at QA1.net

Technical Support Line: (952) 985-5675 Email: sales@QA1.net

INSTALLATION INSTRUCTIONS

QA1 P/N 52525 '82-'92 F-Body Pro Touring Control Arms

QA1 P/N 52925 '82-'92 F-Body Drag Race Control Arms

QA1 P/N 52566 (Pro Touring), 52766 (Street), 52966 (Drag Race) '82-'04 S-S10, S15, Sonoma Control Arms

F-BODY CONTROL ARMS

52525 Pro Touring Arms

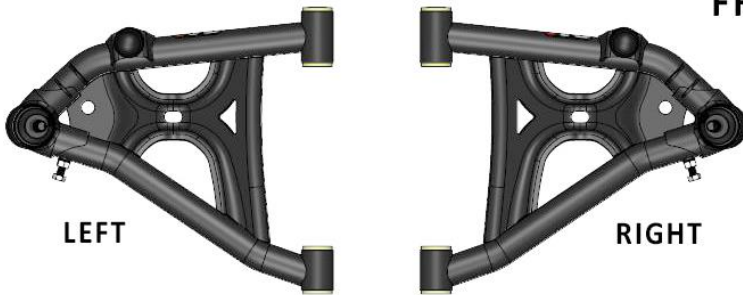

LEFT

RIGHT

Can be used with coil-over struts or QA1 Spring Slider

FRONT

52925 Drag Race Arms

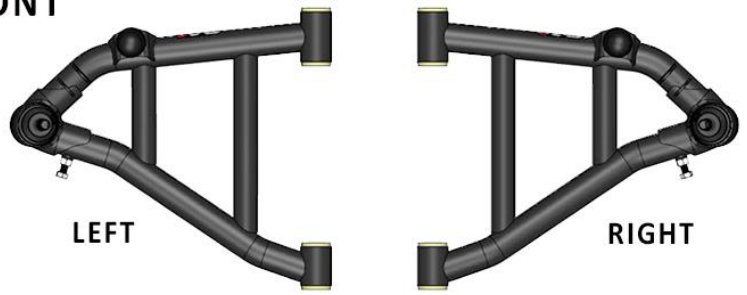

LEFT

RIGHT

Must be used with coil-over struts

TOOLS AND SUPPLIES REQUIRED

- Floor Jack
- Jack Stands
- Wrench Set
- Hex Key Set
- Spring Compressor
- Ball Joint Separator
- Ratchet & Socket Set

Pre-Installation Notes:

1. These instructions cover both S-Series trucks and F-Body cars due to the similar sway bar end link connections but are slightly different in installation. Refer to the S-Series or F-Body sections below.
2. QA1 does not recommend driving the vehicle until it has been properly aligned due to major changes in suspension geometry that will affect the handling characteristics of the vehicle. *A front-end alignment should be performed by a qualified alignment shop after any changes to the suspension system. Recommended alignment settings can be found at the end of these instructions.*
3. 3rd gen F-body arms and S-Series Drag Race arms use IGUS bushings that need very little grease. A small amount of general purpose chassis grease is applied during production. F-body arms use flush grease fittings that can be greased using a needle fitting. If grease is added, only use 1 to 2 pumps of a quality general purpose chassis grease.
4. Ball joints are assembled with a small amount of lithium grease. A very small amount of lithium grease can be added if desired. Do not use more than 1 pump of grease.

S-Series Truck Disassembly-

- 1) Raise and support the vehicle by the frame with jack stands on a stable surface and remove front wheels.
- 2) Remove the sway bar end links. (if equipped)
- 3) If using a non-coil-over shock, unbolt the two lower shock mounting bolts. If the vehicle has coil-over shocks installed, remove the upper shock bolt at this time and only remove the lower shock connection after the spring pressure is relieved in step 6.
- 4) Remove the cotter pin from the lower ball joint and loosen the castle nut. Do not remove the nut at this time.
- 5) Separate the lower ball joint from the spindle using a ball joint separator.
- 6) With a jack under the lower control arm, remove the ball joint nut and slowly lower the control arm to release the spring pressure. A spring compressor should be used if lowering the arm does not release all spring pressure.
- 7) Remove the control arm pivot bolts noting the direction they are installed.

S-Series Truck Installation using QA1 Pro Coil Coil-over Kit-

QA1 coil-over shocks come with poly bushings and t-bars installed in the lower shock connection for customers who are using factory control arms. QA1 control arms require the lower shock bushing to be swapped out with the included spherical bearing mount.

1. Install the provided spherical bearing kit into the lower shock mount using the following steps:



2. Hold the new QA1 lower control arm in place and insert the included pivot bolts. **(Figure 1)** Install the wider front pivot point with the longer mounting bolt. S10 arms use a 14mm bolt in the front pivot and a shorter 12mm in the rear connection. Torque hardware to 65 lb. ft.

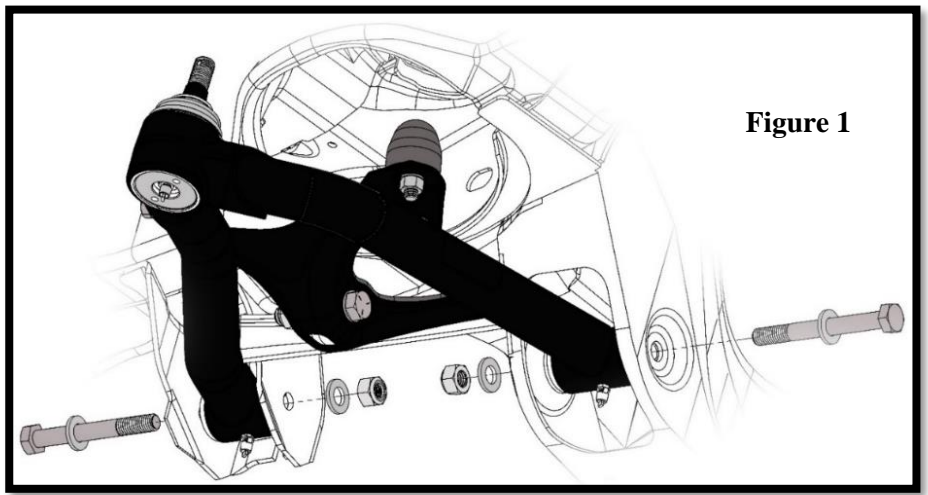

3. Refer to the instructions included with the shocks for coil-over assembly.
4. Install the coil-over shock to the control arm using the included 1/2" x 2.5" hardware, with two washers and one nyloc nut. Torque the lower shock bolt to 50 lb. ft.
5. Connect the lower ball joint into the spindle. Torque to 65 lb. ft. Continue tightening to line up the cotter pin hole. Never loosen the ball joint to find the cotter pin hole. Install a new cotter pin.

F-Body Disassembly-

- 1) Raise and support the vehicle by the frame with jack stands on a stable surface and remove front wheels.
- 2) Remove the sway bar end links. (if equipped)
- 3) Support the lower control arm with a jack to contain the spring pressure.
- 4) Loosen the castle nut from the ball joint, but do not remove the nut at this time.
- 5) With the castle nut still threaded on the ball joint stud, separate the lower ball joint from the spindle using a ball joint separator.
- 6) Slowly lower the jack to relieve the spring pressure. A spring compressor should be used if lowering the arm does not release all spring pressure.
- 7) Remove the control arm pivot bolts noting the direction they are installed.

F-Body Installation-

- 1) Identify the right/left arms using the photo at the top of page 1.
- 2) Install the control arms using the included M12 x 110mm long bolts in the front connection with two washers and one nyloc nut.
- 3) Install the slightly shorter M12 x 100mm long bolts in the rear connection with two washers and one nyloc nut.
- 4) Torque both 12mm connections to 65 lb. ft.
- 5) Install the spindle onto the ball joint followed by one 9/16" washer and castle nut. Torque to 65 lb. ft. Continue tightening to line up the cotter pin hole. Never loosen the ball joint to find the cotter pin hole. Install a new cotter pin.
- 6) If installing these arms with the QA1 Spring Sliders, refer to the K-member instructions.

Sway Bar End Link Installation (Both S-Series and F-Body)-

QTY/KIT	DESCRIPTION	2ND DESCRIPTION	WHERE USED ON VEHICLE
2	BOLT, HEX 3/8-24 X 2.5"	GRADE 5, CLEAR ZINC, PARTIAL THREAD	SWAY BAR LINK BOLT
2	NUT, HEX 3/8-24	GRADE 5, CLEAR ZINC	SWAY BAR LINK NUT
2	BOLT, HEX 3/8-16 X 2.0"	GRADE 5, CLEAR ZINC, PARTIAL THREAD	SWAY BAR LINK TO LCA
2	NUT, NYLOCK, 3/8-16	GRADE 5, CLEAR ZINC	
4	WASHER, FLAT 3/8" SAE	.406" ID X .812" OD X .065", CLEAR ZINC	

- 1) Attach one rod end (**#3**) to the sway bar mounting tabs on the control arm using 3/8" x 2" bolt with two washers and one nyloc nut. Torque to 31 lb. ft.
- 2) Sandwich the end of the factory or QA1 sway bar between two bushings (**#2**) and two washers (**#1**) with one 3/8" x 2.5" bolt inserted down through the bushings and washers. (**Figure 2**)
- 3) Thread one 3/8" jam nut onto the bolt before threading it down into the rod end.
- 4) Tighten the bolt into the rod end until the bushings are slightly compressed and firmly holding the end of the sway bar.
- 5) Tighten the jam nut against the rod end to secure the connection.

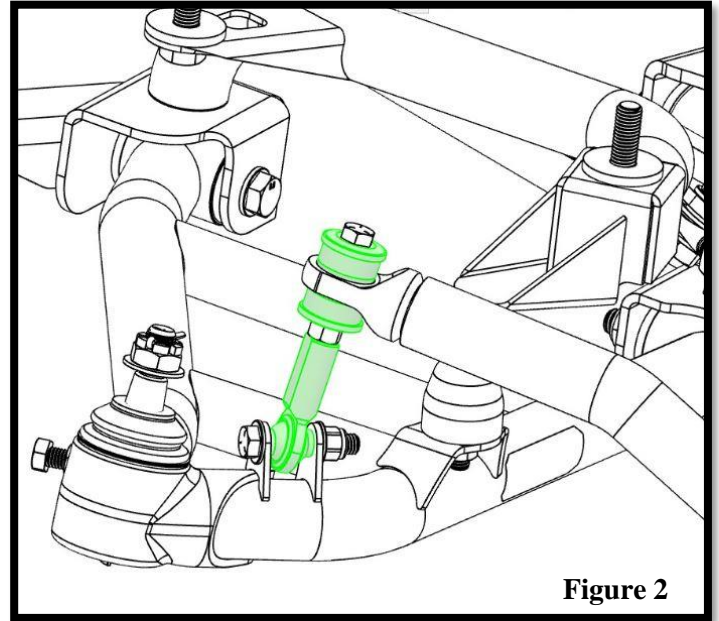

BALLOON	DESCRIPTION	QTY.
<u>1</u>	WASHER, SWAY BAR BUSHING	<u>4</u>
<u>2</u>	BUSHING, SWAY BAR END LINK	<u>4</u>
<u>3</u>	ROD END (PC) 2-PC ALLOY HT	<u>2</u>

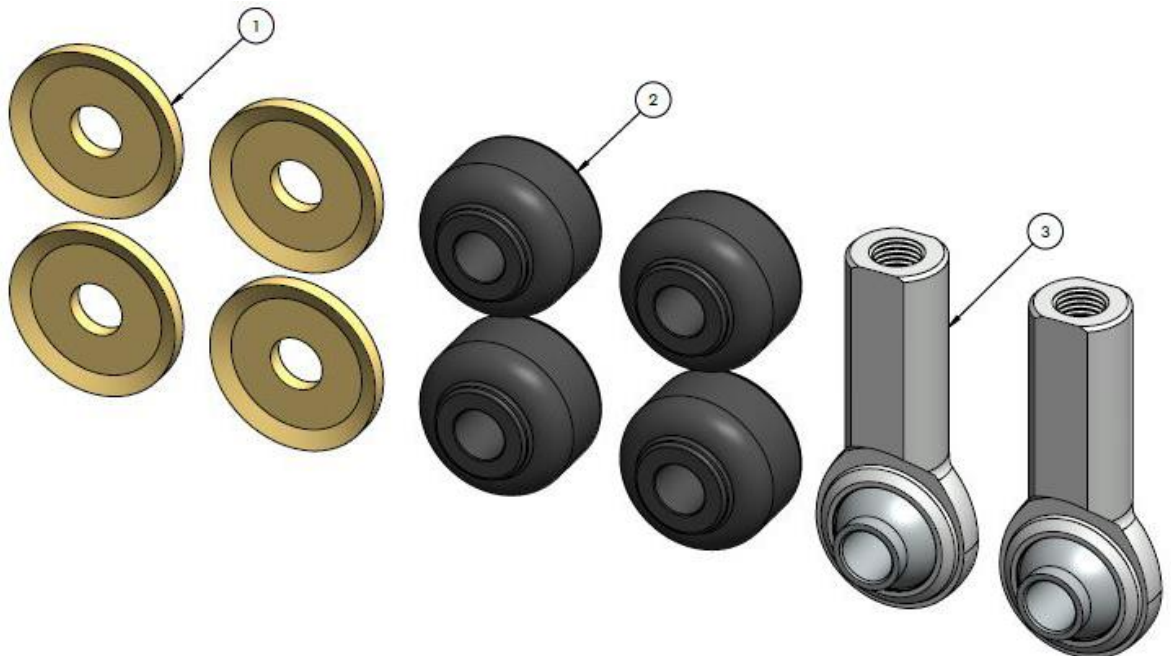

A PROFESSIONAL ALIGNMENT SHOULD BE PERFORMED BEFORE DRIVING THE VEHICLE



NOTE:

Each control arm has an adjustable steering stop bolt that the spindle will contact at full steering lock. The steering stop can be adjusted by adding or removing the 3/8" washers. Torque to 31 lb. ft. after adjustments are made.



Technical Support Line: (952) 985-5675 Email: sales@QA1.net

READ ALL INSTRUCTIONS CAREFULLY AND THOROUGHLY PRIOR TO STARTING INSTALLATION. PRODUCTS THAT HAVE BEEN INSTALLED ARE NOT ELIGIBLE FOR RETURN. USE THE PROPER JACKING LOCATIONS. DEATH OR SERIOUS INJURY CAN RESULT IF INSTRUCTIONS ARE NOT CORRECTLY FOLLOWED. A GOOD CHASSIS MANUAL, AVAILABLE AT YOUR LOCAL PARTS STORE, MAY ALSO AID IN YOUR INSTALLATION.

• **DISCLAIMER / WARRANTY** •

QA1 WARRANTS THAT THE PRODUCTS WILL BE FREE FROM DEFECTS IN MATERIAL AND WORKMANSHIP FOR ONE YEAR FROM DATE OF SALE TO THE ORIGINAL PURCHASER. QA1 MAKES NO OTHER WARRANTY OF ANY KIND, EXPRESS OR IMPLIED. QA1 SHALL HAVE NO OBLIGATION UNDER THE FOREGOING WARRANTY WHERE THE DEFECT IS THE RESULT OF IMPROPER OR ABNORMAL USE, YOUR NEGLIGENCE, VEHICLE ACCIDENT, IMPROPER OR INCORRECT INSTALLATION OR MAINTENANCE, NOR WHEN THE PRODUCT HAS BEEN REPAIRED OR ALTERED IN ANY WAY. QA1'S LIABILITY IN THE CASE OF DEFECTIVE PRODUCTS SUBJECT TO THE FOREGOING WARRANTY SHALL BE LIMITED TO THE REPAIR OR REPLACEMENT, AT QA1'S OPTION, OF THE DEFECTIVE PRODUCTS.

THE USER UNDERSTANDS AND RECOGNIZES THAT RACING PARTS, SPECIALIZED STREET ROD EQUIPMENT, AND ALL PARTS AND SERVICES SOLD BY QA1 ARE EXPOSED TO MANY AND VARIED CONDITIONS DUE TO THE MANNER IN WHICH THEY ARE INSTALLED AND USED. QA1 SHALL BEAR NO LIABILITY FOR ANY LOSS, DAMAGE OR INJURY, EITHER TO A PERSON OR TO PROPERTY, RESULTING FROM THE INSTALLATION, DIRECT OR INDIRECT USE OF ANY QA1 PRODUCTS OR INABILITY BY THE BUYER TO DETERMINE PROPER USE OR APPLICATION OF QA1 PRODUCTS. WITH THE EXCEPTION OF THE LIMITED LIABILITY WARRANTY SET FORTH ABOVE, QA1 SHALL NOT BE LIABLE FOR ANY CLAIMS, DEMANDS, INJURIES, DAMAGES, ACTIONS, OR CAUSES OF ACTION WHATSOEVER TO BUYER ARISING OUT OF OR CONNECTED WITH THE USE OF ANY QA1 PRODUCTS. MOTORSPORTS ARE DANGEROUS; AS SUCH, NO WARRANTY OR REPRESENTATION IS MADE AS TO THE PRODUCT'S ABILITY TO PROTECT THE USER FROM INJURY OR DEATH. THE USER ASSUMES THAT RISK!

DEDICATED TECH SUPPORT

QA1 is dedicated to providing quality support and instructions. We employ passionate racers and car enthusiasts that know our products and the industry to better serve you.

CHECK US OUT ON YOUTUBE!



- Frequently Asked Questions
- Quick Tips
- Install Information
- Tuning and Repair Guides
- Other Technical Information

youtube.com/qa1tech



linkedin.com/company/qa1



instagram.com/qa1motorsports



facebook.com/qa1motorsports

www.qa1.net/tech