



These instructions can be found in color and expandable at QA1.net

Technical Support Line: (952) 985-5675 Email: sales@QA1.net

**INSTALLATION INSTRUCTIONS**

QA1 P/N 52025 '82-'92 F-Body K-Member Kit  
QA1 P/N SS304-07650, SS304-07850 '82-'92 F-Body Spring Slider Kit  
QA1 P/N 7740-478 thru 7740-480 '82-'92 F-Body Engine Mounts

**TOOLS AND SUPPLIES REQUIRED**

- Floor Jack
- Jack Stands
- Spring Compressor
- QA1 Engine Mounts & Control Arms
- Wrench Set
- Socket Set
- Engine Hoist
- M12-1.75 tap
- Anti-seize

**PRE-INSTALLATION NOTES**

This k-member requires the use of QA1 control arms and engine mounts purchased separately. Factory control arms cannot be used with this K-member.

<b>QA1 Engine Mounts</b>	<b>Part Number</b>
Small Block/Big Block	7740-480
LS	7740-478
LT	7740-479

<b>QA1 Control Arms</b>	<b>Part Number</b>
Pro Touring	52525
Drag Race	52925*

\*Drag Race arms must use coil-over studs. Will not work with Spring Slider.

This k-member and control arms can be run with a coil-over strut or the QA1 Spring Slider Kit (sold separately), which uses an inboard, ride height adjustable spring that allows more alignment clearance for lowered vehicles compared to a coil-over strut. The upper mount of the Spring Slider Kit is mounted between the K-member and chassis and is detailed in this installation.

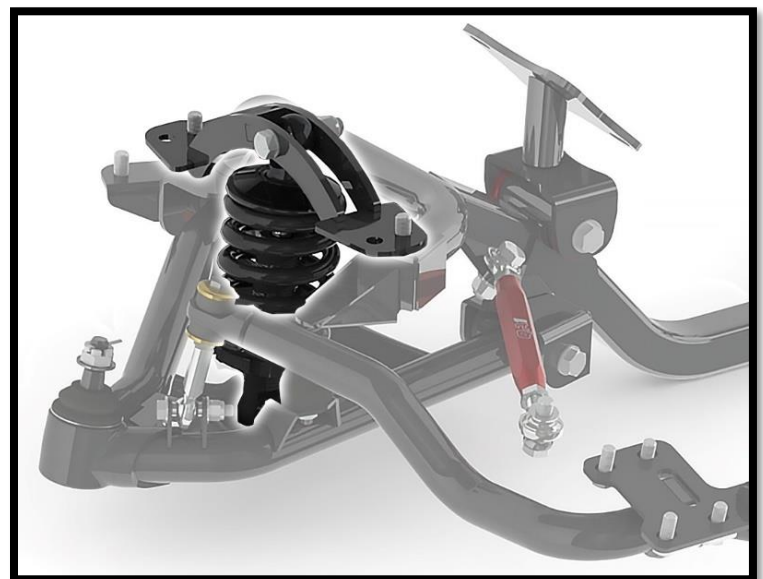

**REMOVAL:**

1. Raise the front of the car and place it on jack stands. **SEE YOUR CAR'S OWNER'S MANUAL FOR PROPER JACKING LOCATIONS AND SUSPENSION DISASSEMBLY. DEATH OR SERIOUS INJURY CAN RESULT IF INSTRUCTIONS ARE NOT CORRECTLY FOLLOWED.**
2. Start the k-member installation by inspecting chassis components. Look for worn out bushings, ball joints, etc. Now is a good time to replace worn components.

3. Remove the wheels.
4. Remove the sway bar end link bolts and bushings from the lower control arms.
5. If the vehicle is equipped, remove the triangle braces from the left and right side of the k-member. **(Figure 1)**
6. With the A-arms supported by a jack, loosen the ball joint castle nut but **DO NOT REMOVE THE NUT AT THIS TIME**. Separate the ball joint from the spindle using a hammer or ball joint separator.
7. Remove the ball joint castle nut and slowly, **CAREFULLY**, lower the A-arm assembly down until the spring is free and can be removed. (This may require the use of a spring compressor.) Repeat the procedure for both sides.

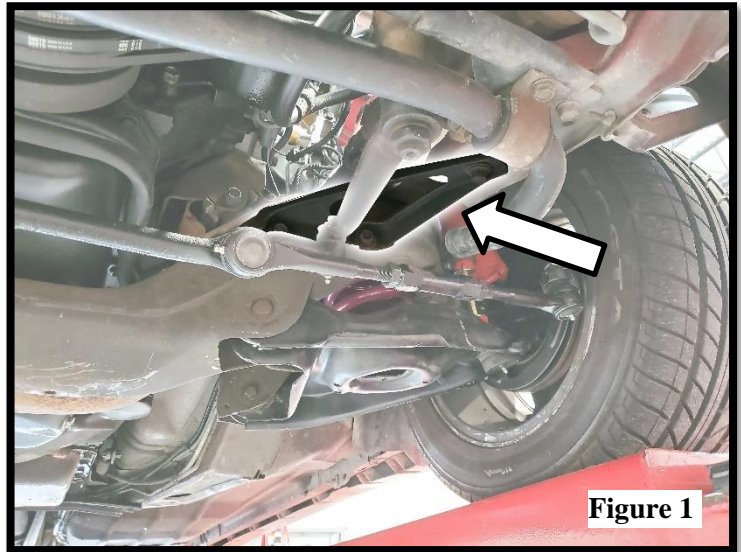

**Figure 1**

8. Remove the struts from the spindles. If the vehicle is already equipped with coil-over struts or the spring slider will be used, non coil-over struts can remain on the vehicle.
9. Remove the lower control arm pivot bolts to remove the A-arms from the vehicle.
10. Unbolt the brake line routed along the top of the factory k-member by removing the five mounting bolts. **(Figure 2)**

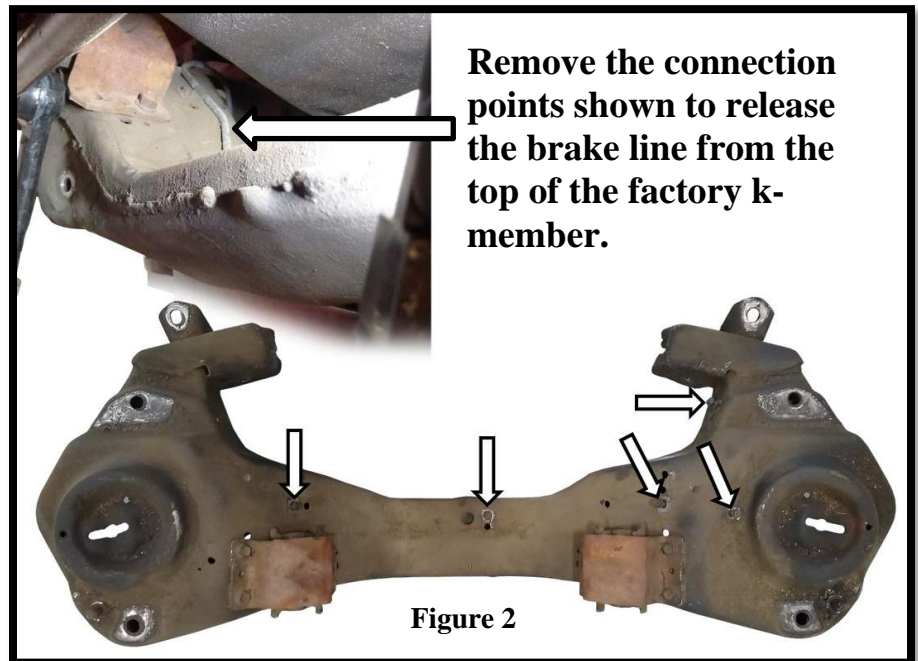

**Figure 2**

11. Support the engine with an engine hoist or suitable support fixture, taking pressure off the factory k-member. Whichever method used to support the engine weight, **DO NOT REMOVE ENGINE SUPPORT UNTIL NEW K-MEMBER IS INSTALLED AND TORQUED.**

12. Remove the engine mount bolts from the stock k-member.
13. Support the stock k-member with a floor jack. During the removal process a couple of helpers will be needed. One on each side of the k-member and one operating the floor jack.
14. Unbolt and carefully lower the k-member and slide from under the car.
15. Remove the engine mounts from the engine block. Note the location of each bolt and retain the mounting hardware for reinstallation.

**K-MEMBER INSTALLATION:**

1. In preparation for the new k-member install, clean the chassis of any dirt or debris at the K-member mounting locations. The QA1 k-member mounts in the same location as the factory K-member.
2. Chase the 6 factory floating nuts of the k-member mounts with an M12-1.75 tap.

- If using the QA1 Spring Slider Kit, install the QA1 k-member to the frame with the upper Spring Slider mount between the k-member and frame with the support cross-brace towards the rear of the vehicle and mounted using the inboard holes. **(Figure 3)** The upper Spring Slider mounts are not right/left specific. For vehicles running coil-over struts, install one 1.5" O.D. x .18" thick spacer between the k-member and frame on the four k-member connections shown. **(Figure 3)** Use six M12 x 40mm long bolts with washers to mount the k-member to the frame. Evenly torque all M12 hardware to 65 lb. ft.

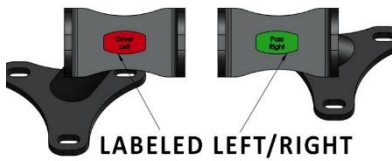
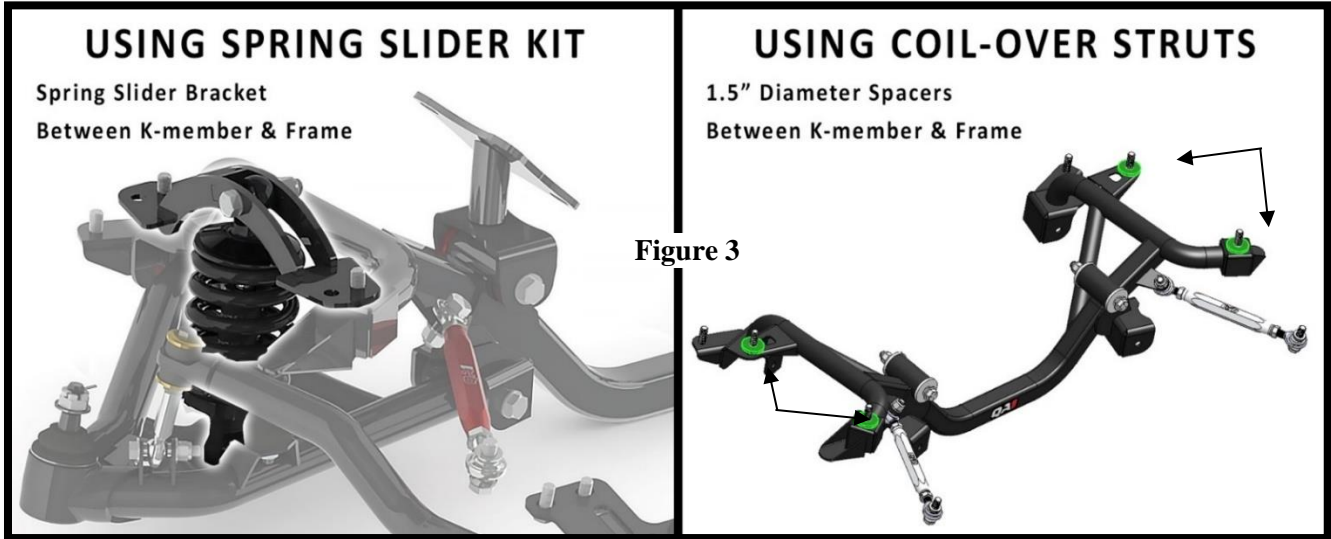
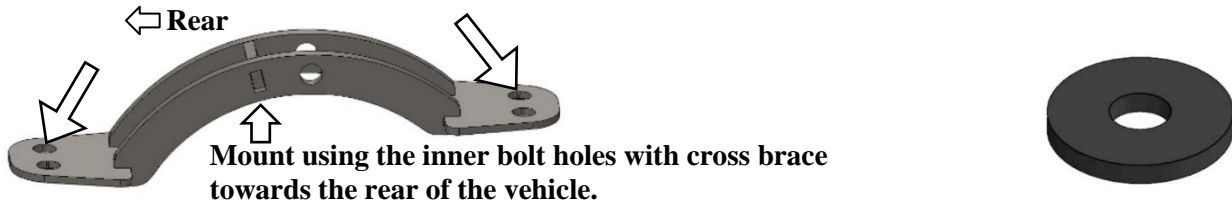

**ENGINE MOUNT INSTALLATION:**

- Identify the right (passenger) and left (driver) side engine mounts by their identifying stickers. **(Figure 4)**
- Referring to the parts layout on page 5, install two poly bushings (#3) from the install kit into the bushing cans of the k-member, with one sleeve (#4) through the center of each. A small amount of grease on the sleeve and large slip-joint plier will aid in the installation. **(Figure 5)**
- Loosely install the engine mount to the engine block reusing the factory hardware.

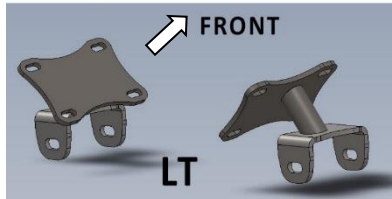
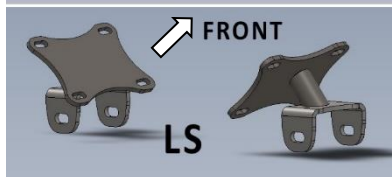
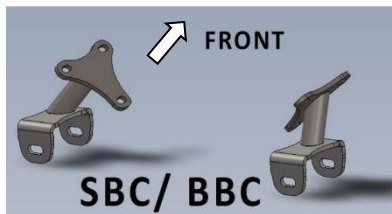

**Figure 4**

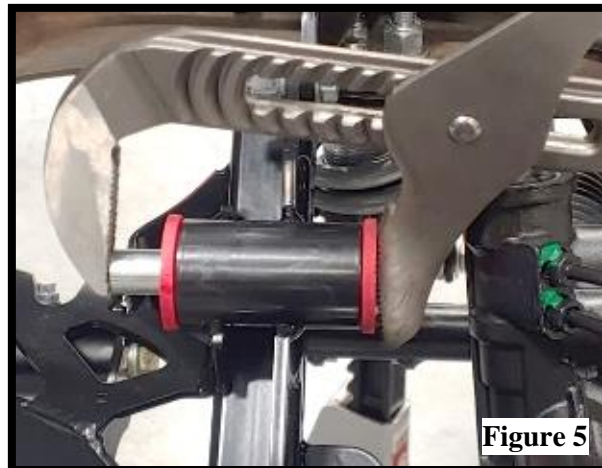

- Secure the clevis end of the engine mount to the bushing can of the k-member using the included 1/2" x 5" bolts with two washers and one nyloc nut per mount. **(Figure 6)**
- Torque the engine block bolts to the factory specification, typically 25 lb. ft. for aluminum blocks and 35 lb. ft. for cast iron blocks.
- Torque the engine mount to k-member hardware to 75 lb. ft.

**NOTE:**

If a coil-over strut will be used, refer to the installation instructions included with the coil-over struts and control arms. Disregard the Spring Slider installation details as the Spring Slider should not be installed with a coil-over strut.

**SPRING SLIDER INSTALLATION:**

- Refer to the control arm instructions to Install the QA1 lower control arms on the K-member with the mounting bolts provided with the control arms. If coil-over struts are being used, skip to step 7 or move to step 2 if QA1 spring sliders are being used.
- With the spring seat collar near the bottom of the threads, apply anti-seize to the threads of the slider body.
- Coat both sides of the included thrust washers with anti-seize. Install the stainless-steel spring seat washer onto the installed collar before the needle bearing, followed by the second washer. The completed thrust bearing kit should resemble a needle bearing sandwich. **(Figure 7)**
- Install the spring onto the slider then slide the slotted upper spring seat over the spring. The spring seat will need to be threaded all the way down the body to fit the spring/upper spring seat. The Spring Slider assembly is now complete. **(Figure 8)**
- Install the spring slider assembly onto the upper mount using one 1/2" x 2.5" bolt with two washers and one nyloc nut included with the spring slider kit. **(Figure 9)**
- Install the lower connection of the spring slider into the lower control arm. Secure the spring slider to the control arm using one 1/2" x 2.5" bolt with two washers and one nyloc nut included with the lower control arm set. Torque the upper and lower spring slider connections to 85 lb. ft.
- If reusing the factory front sway bar, use the factory end links to the mounting hole in the QA1 control arm. If using the QA1 front sway bar (p/n 52825), refer to the installation instructions included with the sway bar to mount to the QA1 control arm.

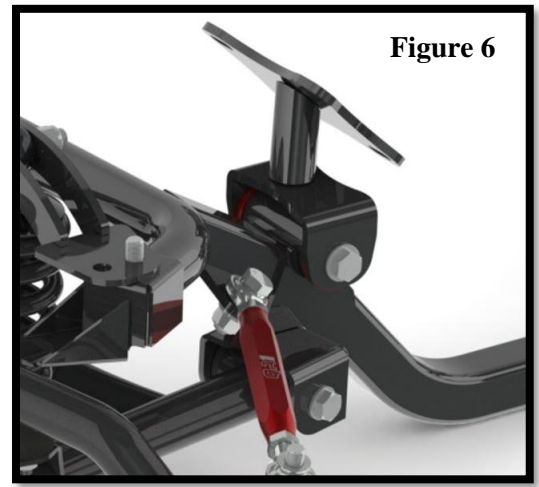

**Figure 6**

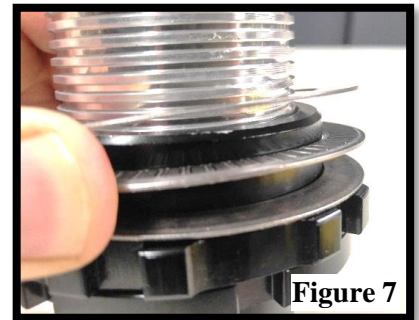

**Figure 7**



**Figure 8**

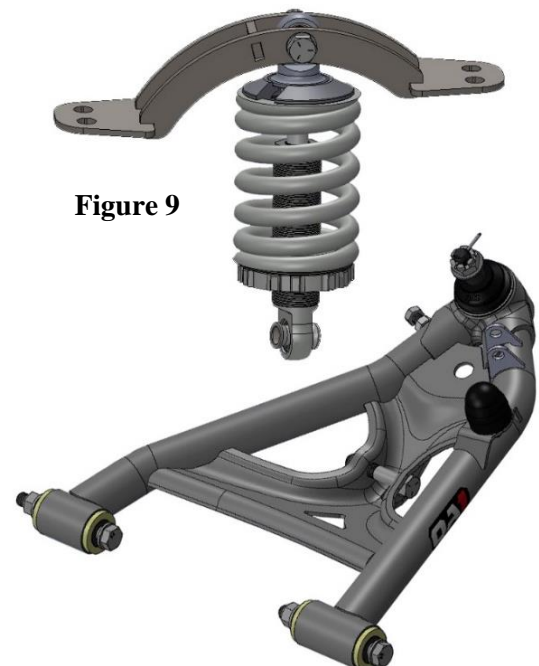

**Figure 9**

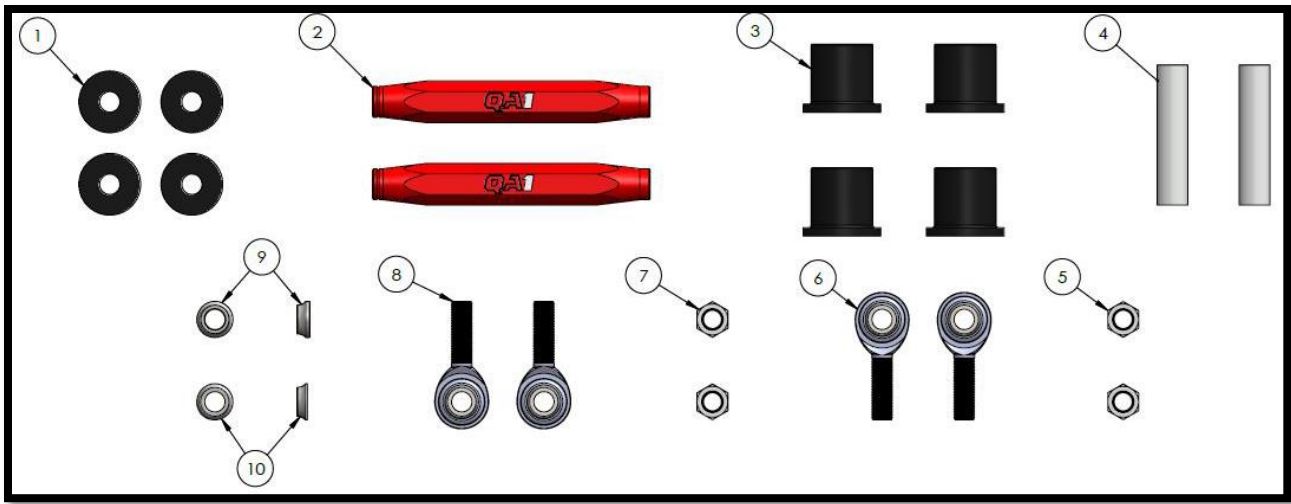

BALLOON #	ITEM #	DESCRIPTION	QTY.
1	7740-471	PLATE, SPRING PERCH DELETE	4
2	9033-515	SLEEVE, ALUMINUM HEX, .875" X 6.75"	2
3	9032-428	BUSHING, POLY 2-PIECE .75" ID, BLACK	4
4	9033-509	SLEEVE, .500" ID X .750" OD X 3.400"	2
5	JNR8S	JAM NUT, STEEL 1/2-20 RH	2
6	CMR8	ROD END (C) 2-PC CARBON	2
7	JNL8S	JAM NUT, STEEL 1/2-20 LH	2
8	CML8	ROD END (C) 2-PC CARBON	2
9	SG85	SPACER ROD END SS, 1/2" ID	2
10	SG84	SPACER ROD END SS, 1/2" ID	2

**STABILIZER ROD INSTALLATION:**

1. Thread one left-hand threaded jam nut (#7) onto each of the two left-hand threaded rod ends (#6).
2. Thread one right-hand threaded jam nut (#5) onto each of the two right-hand threaded rod ends (#8).
3. Fully thread one right-hand threaded rod end into the right-hand threaded end of the hex sleeves (#2). Do the same with the left-hand rod ends into the opposite side of the hex sleeves.
4. Install one end of the assembled hex sleeve to the tab near the front of the k-member using one M12 x 40mm bolt with two washers and one nyloc nut. (Figure 10)
5. Install the forward hex sleeve connection to the vehicles frame with one thicker spacer (#9) between the rod end and the frame and one SG84 (#10) spacer between the rod end and the bolt head. (Figure 11)

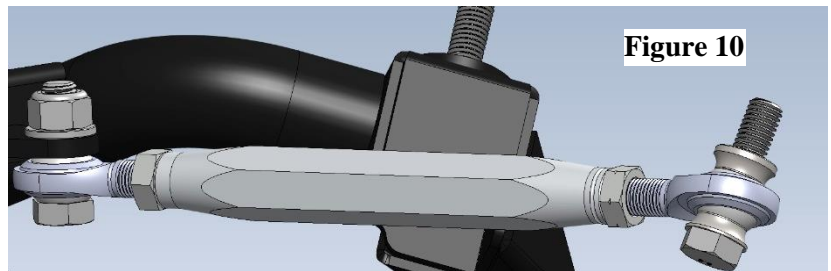

**Stabilizer Rod Hardware Kit**

QTY/KIT	DESCRIPTION	2ND DESCRIPTION	QA1 ITEM#	WHERE USED ON VEHICLE
8	BOLT, HEX, M12-1.75 X 40MM	CLASS 8.8, CLEAR ZINC, DIN 933	NA	K-MEMBER TO FRAME/BRACE
8	WASHER, FLAT, M12	24MM OD X 13MM ID X 2.5MM, CLEAR ZINC, DIN 125	9005-280	K-MEMBER TO FRAME/BRACE
2	BOLT, HEX, M12-1.75 X 50MM	CLASS 8.8, CLEAR ZINC, DIN 933	NA	BRACE TO FRAME
2	NUT, NYLOCK M12-1.75	CLASS 8.8, CLEAR ZINC, DIN 985	9014-430	BRACE TO K-MEMBER
2	BOLT, HEX, 1/2-13 X 5.0"	GRADE 5, CLEAR ZINC, PARTIAL THREAD	NA	ENGINE MOUNT TO K-MEMBER
2	NUT, NYLOCK, 1/2-13	GRADE 5, CLEAR ZINC	9014-520	
4	WASHER, FLAT, 1/2" SAE	.531" ID X 1.062" OD X .084" THICK, CLEAR ZINC	9005-228	

Figure 11

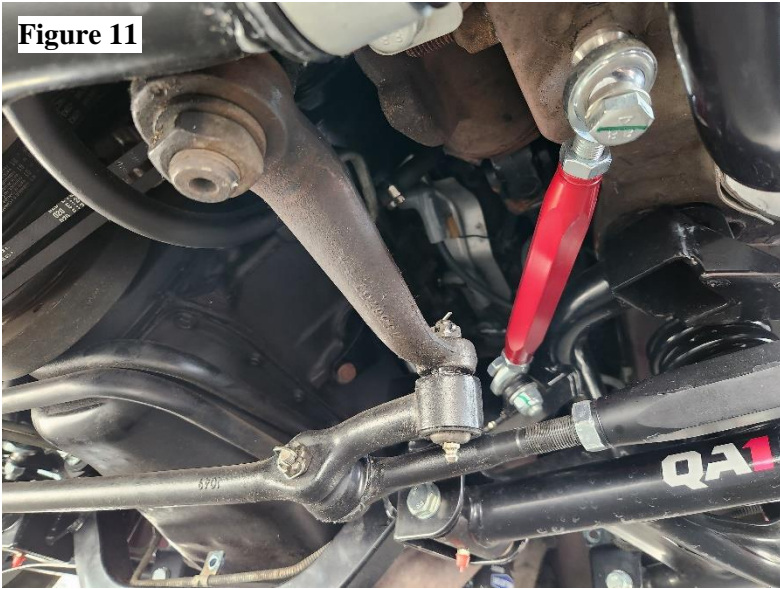

**FINALIZING THE INSTALLATION:**

1. Secure the brake line previously running across the factory k-member to the new k-member using cable ties.
2. Double check all work and hardware torque. It's a basic and overlooked practice that distinguishes the most effective builders from the rest.
3. Lower the car to the ground and bounce the suspension to seat the springs. Rolling the vehicle a couple feet back and forth will help settle the suspension and will lead to more accurate ride height measurements. Raise the car off the ground and adjust the ride height as necessary using a 3/8" drive ratchet and the included spanner wrench. Once you have the ride height set, tighten the set screw on the adjustment collar.

**An alignment should be performed by a reputable alignment shop after any changes to the suspension.**

**A PROFESSIONAL WHEEL ALIGNMENT IS RECOMMENDED BEFORE DRIVING THE VEHICLE.**

**Recommended Alignment Specs:**

Camber	-0.5° ±0.5°
Caster:	4.7° ±0.5°
Toe:	0.1° ±0.1°

# DEDICATED TECH SUPPORT

QA1 is dedicated to providing quality support and instructions. We employ passionate racers and car enthusiasts that know our products and the industry to better serve you.

**CHECK US OUT ON YOUTUBE!**



- Frequently Asked Questions
- Quick Tips
- Install Information
- Tuning and Repair Guides
- Other Technical Information



- [linkedin.com/company/qa1](https://www.linkedin.com/company/qa1)
- [instagram.com/qa1motorsports](https://www.instagram.com/qa1motorsports)
- [facebook.com/qa1motorsports](https://www.facebook.com/qa1motorsports)

**[www.qa1.net/tech](http://www.qa1.net/tech)**

# Header and Oil Pan Fitment

## LS Engines

Truck intake manifolds are too tall and truck oil pans hang too low.

LS engines can use 4<sup>th</sup> Gen F-body (98-02) accessory drives with the stock low mount A/C compressor. Coil relocations are needed to clear the A/C box.

LS engines will have 8 ¼" from the top of the valley cover to the bottom of the QA1 strut tower brace (if equipped) for intake clearance.

## Gen V LT based engines

Truck intake manifolds are too tall and truck oil pans hang too low.

Coil relocations will be needed to clear the A/C box.

LT engines will have 8" from the top of the valley cover to the bottom of the QA1 strut tower brace (if equipped) for intake clearance. The 6<sup>th</sup> Gen Camaro LT intake is a good option for these swaps and will work with the factory wiper motor.

Below are the oil pans and headers that were test fit by QA1.

### Note:

Small block Chevy engines used in these cars came with a two-piece rear seal through 1985 and a one-piece rear seal from 1986 on. QA1 test fit with the OE replacement pan for the one-piece seal. These pans have the same shape but are not interchangeable on the engine due to the rear seal. The stock or stock replacement oil pans for 82-92 F-bodies will fit the QA1 K-member.

Big Block Chevy: The SUM-G3533 is a stock replacement pan that fits most GM vehicles from 1965 through 1990. With big blocks not being an option in the 3<sup>rd</sup> gen F-body, QA1 cannot verify header/oil pan fitment outside of the listed components.

ENGINE	HEADERS	OIL PAN
SBC	HEDMAN 68460	SUM-G3503X (stock replacement, 1 pc rear main seal)
BBC	HOOKER 226HKR	SUM-G3533
LT	ULTIMATE HEADERS 112521	HOLLEY 302-20
LS	HEDMAN 45740 ULTIMATE HEADERS 102631	DORMAN 264-331 HOLLEY 302-2



9919-329





Technical Support Line: (952) 985-5675 Email: sales@QA1.net

READ ALL INSTRUCTIONS CAREFULLY AND THOROUGHLY PRIOR TO STARTING INSTALLATION. PRODUCTS THAT HAVE BEEN INSTALLED ARE NOT ELIGIBLE FOR RETURN. USE THE PROPER JACKING LOCATIONS. DEATH OR SERIOUS INJURY CAN RESULT IF INSTRUCTIONS ARE NOT CORRECTLY FOLLOWED. A GOOD CHASSIS MANUAL, AVAILABLE AT YOUR LOCAL PARTS STORE, MAY ALSO AID IN YOUR INSTALLATION.

• **DISCLAIMER / WARRANTY** •

QA1 WARRANTS THAT THE PRODUCTS WILL BE FREE FROM DEFECTS IN MATERIAL AND WORKMANSHIP FOR ONE YEAR FROM DATE OF SALE TO THE ORIGINAL PURCHASER. QA1 MAKES NO OTHER WARRANTY OF ANY KIND, EXPRESS OR IMPLIED. QA1 SHALL HAVE NO OBLIGATION UNDER THE FOREGOING WARRANTY WHERE THE DEFECT IS THE RESULT OF IMPROPER OR ABNORMAL USE, YOUR NEGLIGENCE, VEHICLE ACCIDENT, IMPROPER OR INCORRECT INSTALLATION OR MAINTENANCE, NOR WHEN THE PRODUCT HAS BEEN REPAIRED OR ALTERED IN ANY WAY. QA1'S LIABILITY IN THE CASE OF DEFECTIVE PRODUCTS SUBJECT TO THE FOREGOING WARRANTY SHALL BE LIMITED TO THE REPAIR OR REPLACEMENT, AT QA1'S OPTION, OF THE DEFECTIVE PRODUCTS.

THE USER UNDERSTANDS AND RECOGNIZES THAT RACING PARTS, SPECIALIZED STREET ROD EQUIPMENT, AND ALL PARTS AND SERVICES SOLD BY QA1 ARE EXPOSED TO MANY AND VARIED CONDITIONS DUE TO THE MANNER IN WHICH THEY ARE INSTALLED AND USED. QA1 SHALL BEAR NO LIABILITY FOR ANY LOSS, DAMAGE OR INJURY, EITHER TO A PERSON OR TO PROPERTY, RESULTING FROM THE INSTALLATION, DIRECT OR INDIRECT USE OF ANY QA1 PRODUCTS OR INABILITY BY THE BUYER TO DETERMINE PROPER USE OR APPLICATION OF QA1 PRODUCTS. WITH THE EXCEPTION OF THE LIMITED LIABILITY WARRANTY SET FORTH ABOVE, QA1 SHALL NOT BE LIABLE FOR ANY CLAIMS, DEMANDS, INJURIES, DAMAGES, ACTIONS, OR CAUSES OF ACTION WHATSOEVER TO BUYER ARISING OUT OF OR CONNECTED WITH THE USE OF ANY QA1 PRODUCTS. MOTORSPORTS ARE DANGEROUS; AS SUCH, NO WARRANTY OR REPRESENTATION IS MADE AS TO THE PRODUCT'S ABILITY TO PROTECT THE USER FROM INJURY OR DEATH. THE USER ASSUMES THAT RISK!

