



DON'T FORGET
These instructions can be found in color and expandable at QA1.net

Technical Support Line: (952) 985-5675 Email: sales@QA1.net

INSTALLATION INSTRUCTIONS

QA1 P/N 52827, Rear Sway Bar 1967-1969 GM F-Body with QA1 4-link
QA1 P/N 52829, Rear Sway Bar 1968-1972 GM X-Body with QA1 4-link

TOOLS AND SUPPLIES REQUIRED

- Floor Jack
- Jack Stands
- Ratchet & Socket Set
- Torque Wrench
- Marine Grease

PRE-INSTALLATION NOTES-

This rear sway bar was designed to fit the QA1 four link rear suspension and will not work with the factory leaf springs.

Some exhaust systems will need to be re-routed for four link clearance. Be sure to check exhaust to sway bar clearance at ride height.

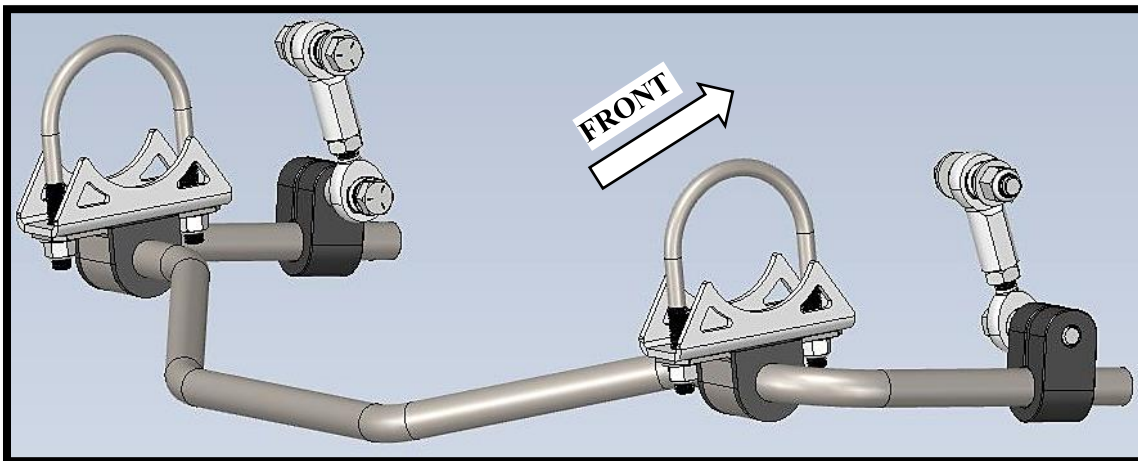

Figure 1



Figure 2

INSTALLATION-

1. Lightly grease the inner bushings with marine grease before loosely mounting the sway bar to the axle using the included u-bolt kit (#7,#8, #9) and sway bar bushing clamps. **(Figure 1 & 2)** The legs of the bar should be pointing towards the front of the vehicle and the rear of the bar biased downward. Leave the u-bolts loose until the bar is fully installed so the angle of the mount can be adjusted.

- Assemble the link using the male (#4) and female (#1) rod ends with jam nuts (#3). Apply a small amount of anti-seize on the threads before assembling.

BALLOON #	ITEM #	DRAWING #	DESCRIPTION	QTY.
1	XFR8	XFR8	ROD END (X) ENDURA ALLOY HT	2
2	SG84	SG84	SPACER, ROD END SS	6
3	JNR8S	JNR8S	JAM NUT, STEEL 1/2-20 RH	2
4	XMR8	XMR8	ROD END (X) ENDURA ALLOY HT	2
5	SG88	SG88	SPACER ROD END SS, 1/2" ID	2
6	9039-401	1006954	BAR CLAMP, ALUMINUM, .875" SWAY BAR	2
7	9012-204	68-9626	U-BOLT, 7/16-20 X 3.125" X 4.5"	2
8	9037-628	1004698	BRACKET, AXLE SADDLE MOUNT, 3 INCH	2
9	9032-173	5337	BUSHING, SWAY BAR FRAME MOUNT 7/8"	1

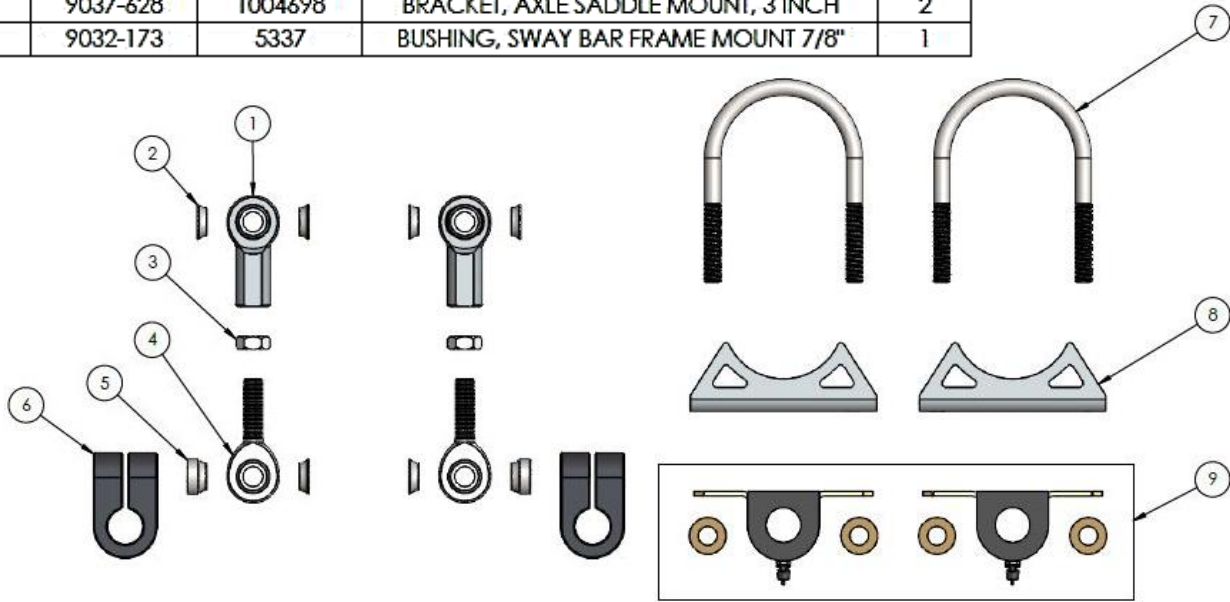

- Slide the bar clamp (#6) onto the leg of the sway bar. (Figure 3 & 4) The bar clamp should be left loose until the sway bar is fully installed and the car is at ride height.
- Install the upper rod end link to the crossmember mount with one SG84 (#2) spacer on each side of the rod end. Secure using 1/2" x 2.5" hardware with two washers and one nyloc nut. Torque to 50 lb. ft.

- Install the lower end of the rod end link to the bar clamp using 1/2" x 3" bolt with one SG84 spacer between the rod end and bolt head, and one SG88 (#5) spacer on the outboard side of the rod end before threading the bolt into the bar clamp. (Figure 3)

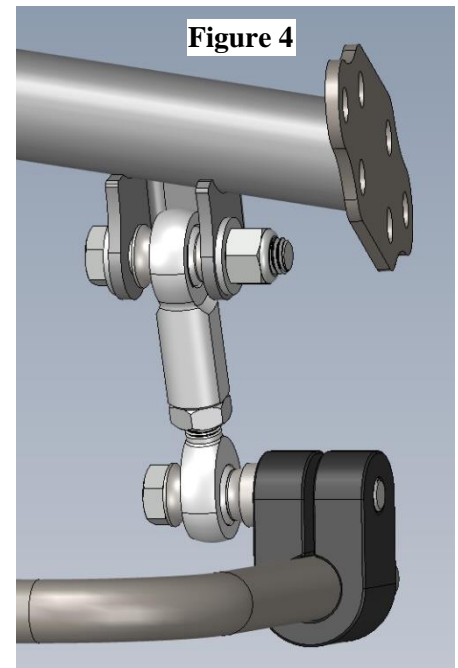
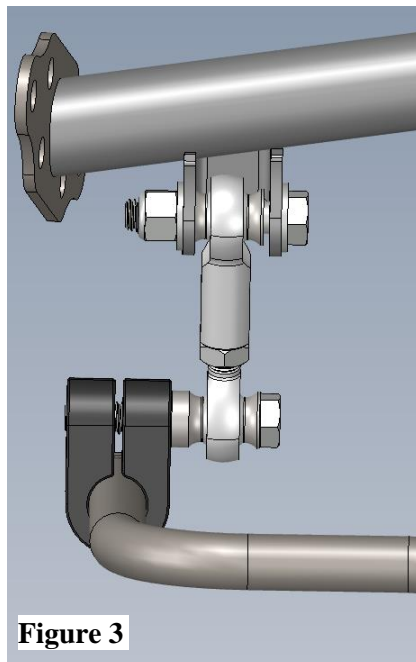

6. With the vehicle at ride height, check all bar clearances. Adjust the axle mounts as needed and ensure an even amount of bar is coming through each bar clamp before torquing the axle u-bolts to 42 lb. ft.
7. Torque the lower bolt into the bar clamp to 50 lb. ft.
8. Double check all bar clearances at ride height before driving.

HARDWARE LISTING:

LINE	QTY/KIT	DESCRIPTION	2ND DESCRIPTION	WHERE USED
1	2	BOLT, HEX 1/2-13 X 2.5"	GRADE 5, CLEAR ZINC	UPPER END LINK
2	4	WASHER, FLAT 1/2" SAE	.54" ID X 1.07" OD X .10", CLEAR ZINC	
3	2	NUT, NYLOCK, 1/2-13	GRADE 5, CLEAR ZINC	
4	2	BOLT, HEX 1/2-13 X 3.0"	GRADE 5, CLEAR ZINC	END LINK TO BAR CLAMP
5	4	NUT, 7/16-20, NYLOCK	GRADE 5, CLEAR ZINC	U-BOLT BUSHING MOUNT
6	4	WASHER, FLAT 7/16" SAE	.47" ID X .92" OD X .07", CLEAR ZINC	
7	4	WASHER, FLAT 3/8" SAE HARDENED	.406" ID X .812" OD X .062" , ECOGUARD®	BOLT ON BUSHING MOUNT
8	4	BOLT, HEX, 3/8-16 X 1.0"	GRADE 5, CLEAR ZINC	

READ ALL INSTRUCTIONS CAREFULLY AND THOROUGHLY PRIOR TO STARTING INSTALLATION. PRODUCTS THAT HAVE BEEN INSTALLED ARE NOT ELIGIBLE FOR RETURN. USE THE PROPER JACKING LOCATIONS. DEATH OR SERIOUS INJURY CAN RESULT IF INSTRUCTIONS ARE NOT CORRECTLY FOLLOWED. A GOOD CHASSIS MANUAL, AVAILABLE AT YOUR LOCAL PARTS STORE, MAY ALSO AID IN YOUR INSTALLATION.

• DISCLAIMER / WARRANTY •

QA1 WARRANTS THAT THE PRODUCTS WILL BE FREE FROM DEFECTS IN MATERIAL AND WORKMANSHIP FOR ONE YEAR FROM DATE OF SALE TO THE ORIGINAL PURCHASER. QA1 MAKES NO OTHER WARRANTY OF ANY KIND, EXPRESSED OR IMPLIED. QA1 SHALL HAVE NO OBLIGATION UNDER THE FOREGOING WARRANTY WHERE THE DEFECT IS THE RESULT OF IMPROPER OR ABNORMAL USE, YOUR NEGLIGENCE, VEHICLE ACCIDENT, IMPROPER OR INCORRECT INSTALLATION OR MAINTENANCE, NOR WHEN THE PRODUCT HAS BEEN REPAIRED OR ALTERED IN ANY WAY. QA1'S LIABILITY IN THE CASE OF DEFECTIVE PRODUCTS SUBJECT TO THE FOREGOING WARRANTY SHALL BE LIMITED TO THE REPAIR OR REPLACEMENT, AT QA1'S OPTION, OF THE DEFECTIVE PRODUCTS.

THE USER UNDERSTANDS AND RECOGNIZES THAT RACING PARTS, SPECIALIZED STREET ROD EQUIPMENT, AND ALL PARTS AND SERVICES SOLD BY QA1 ARE EXPOSED TO MANY AND VARIED CONDITIONS DUE TO THE MANNER IN WHICH THEY ARE INSTALLED AND USED. QA1 SHALL BEAR NO LIABILITY FOR ANY LOSS, DAMAGE OR INJURY, EITHER TO A PERSON OR TO PROPERTY, RESULTING FROM THE INSTALLATION, DIRECT OR INDIRECT USE OF ANY QA1 PRODUCTS OR INABILITY BY THE BUYER TO DETERMINE PROPER USE OR APPLICATION OF QA1 PRODUCTS. WITH THE EXCEPTION OF THE LIMITED LIABILITY WARRANTY SET FORTH ABOVE, QA1 SHALL NOT BE LIABLE FOR ANY CLAIMS, DEMANDS, INJURIES, DAMAGES, ACTIONS, OR CAUSES OF ACTION WHATSOEVER TO BUYER ARISING OUT OF OR CONNECTED WITH THE USE OF ANY QA1 PRODUCTS. MOTORSPORTS ARE DANGEROUS; AS SUCH, NO WARRANTY OR REPRESENTATION IS MADE AS TO THE PRODUCT'S ABILITY TO PROTECT THE USER FROM INJURY OR DEATH. THE USER ASSUMES THAT RISK!

DEDICATED TECH SUPPORT

QA1 is dedicated to providing quality support and instructions. We employ passionate racers and car enthusiasts that know our products and the industry to better serve you.

CHECK US OUT ON YOUTUBE!



- Frequently Asked Questions
- Quick Tips
- Install Information
- Tuning and Repair Guides
- Other Technical Information



- [linkedin.com/company/qa1](https://www.linkedin.com/company/qa1)
- [instagram.com/qa1motorsports](https://www.instagram.com/qa1motorsports)
- [facebook.com/qa1motorsports](https://www.facebook.com/qa1motorsports)

www.qa1.net/tech

[youtube.com/qa1tech](https://www.youtube.com/qa1tech)