

# Installation Manual



## AIR SUSPENSION KIT

Chevrolet Colorado / GMC Canyon (2WD/4WD)\*

*Use the most advanced air springs on the market to eliminate your vehicle's sag, sway and bottoming out. This air suspension kit levels your truck's stance while providing added support for an overall smooth and safe ride.*

\* See application guide for proper fitment.

L6618\_REV1\_06.14.2024 ECN 1-2918

**Thank you and congratulations on the purchase of an Air Suspension kit. Please read the entire manual prior to starting the installation to ensure you can complete it once started.**

## IMPORTANT

This air suspension kit will not increase the GVWR (*Gross Vehicle Weight Rating*), as the GVWR is determined by the vehicle manufacturer. **Do not exceed the maximum capacity listed by the vehicle manufacturer.**

For safe and proper operation of the vehicle, never exceed a maximum of 100PSI in the air springs. Staying under the pressure limit will ensure maximum air spring life. **Failure in doing so may result in damage to your vehicle and/or a void warranty.**

## SAFETY WARNINGS!

**!** Please read and abide the instructions found in this manual, paying close attention to the helpful, cautionary or dangerous warning icons highlighting important safety recommendations and maintenance suggestions throughout this manual.

**+** **HELPFUL INSTALL TIP**  
Additional information that could potentially make the job a little easier.

**!** **PLEASE USE CAUTION**  
Unsafe practices could result in damage to you or your vehicle, or others.

**!** **DANGER WARNING**  
Hazards which could result in severe personal injury or death.

**!** Serious personal injury or death may result from an air spring failure or accident due to improper installation or air spring pressure operation or maintenance.

**!** Inflating an unsecured air spring is dangerous. If it bursts, it could be hurled into the air with explosive force resulting in serious personal injury or death. Never inflate an air spring unless it is secured to the vehicle.

**!** Removing and replacing air springs can be dangerous. This is only a job for a qualified service professional. Never perform air spring service procedures without proper training, tools, and equipment.

## BEFORE STARTING THE INSTALLATION

- Ensure the application information is correct for the make, model and year of the vehicle you are installing the kit on.
  - Some vehicles are equipped with a rear wheel brake proportioning valve. Check with the manufacturer before installing the air spring kit, as it may affect braking performance.
  - It is recommended to use a good quality anti-seize on all fasteners. This will reduce the chance of corrosion on the fasteners and will help facilitate removal, if required at a later date.
- !** **PLEASE NOTE:** This kit contains push-to-connect fittings; using scissors or wire cutters to cut the nylon air line will distort the line and cause the connection to leak. The air line must be cut off squarely with the hose cutter provided in this kit, or a sharp utility knife. **Failure to do so may void the warranty.**



**WARNING:** This product can expose you to the chemical Hexavalent Chromate, which is known to the State of California to cause cancer and birth defects or other reproductive harm. **For more information go to [www.P65Warnings.ca.gov](http://www.P65Warnings.ca.gov)**

## KIT CONTENTS

Please confirm the items below are provided in your kit before starting the installation. Reference the kit explosion diagram on the following page for part assembly.

KIT CONTENTS		QTY	PART #
<b>A</b>	Air Spring 5" Sleeve Style	2	HP10199
<b>B</b>	Upper Bracket (Driver Side)	1	HP1566
<b>C</b>	Upper Bracket (Passenger Side)	1	HP1567
<b>D</b>	Lower Bracket	2	HP2034
<b>E</b>	Clamp Bracket	2	HP1623
<b>F</b>	U-Bolt, 3/8" - 16 x 4.25 x 3.5	2	HP2029
<b>G</b>	J-Bolt	2	HP1337
<b>H</b>	Bolt, 3/8" - 16 x 3/4" Self Threading Flange	4	HP1569
<b>I</b>	Bolt, 1/2" - 13 x 3/4" Flat Head	2	HP1342
<b>J</b>	Washer, 3/8" Flat	2	C653
<b>K</b>	Washer, 1/2" x 2" OD Thin Flat	4	HP1010
<b>L</b>	Nut, 3/8" Nylon Lock	2	HP1000
<b>M</b>	Nut, 3/8" Serrated Flange	4	HP1338
<b>N</b>	Nut, 3/4" Jam	2	HP1076
<b>O</b>	90° Swivel Fitting 1/4" Hose to 1/8" NPT	2	HP1019
<b>P</b>	Heat Shield	1	HP0012
<b>Q</b>	Worm Gear Ring Clamp	2	HP1001

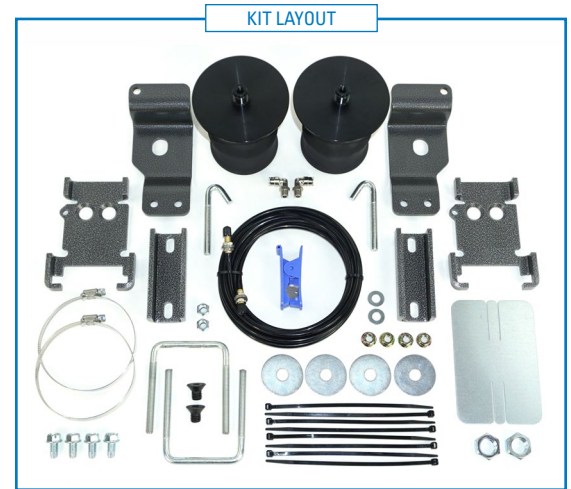

## REQUIRED TOOLS

- Hoist or Floor Jack
- Safety Stands
- Safety Glasses
- Torque Wrench
- Standard Combination Wrenches
- 7/32" Hex Allen Wrench
- 9/16" Crow Foot Wrench
- Ratchet
- Metric & Standard Sockets
- Hose Cutter (included) or Sharp Utility Knife
- Pipe Thread Sealant
- Spray Bottle with Dish Soap/Water
- Air Compressor/Compressed Air Source (to test/fill air springs)

**KIT EXPLOSION DIAGRAM**

**DRIVER SIDE ASSEMBLY SHOWN (Passenger side assembly is mirrored)**

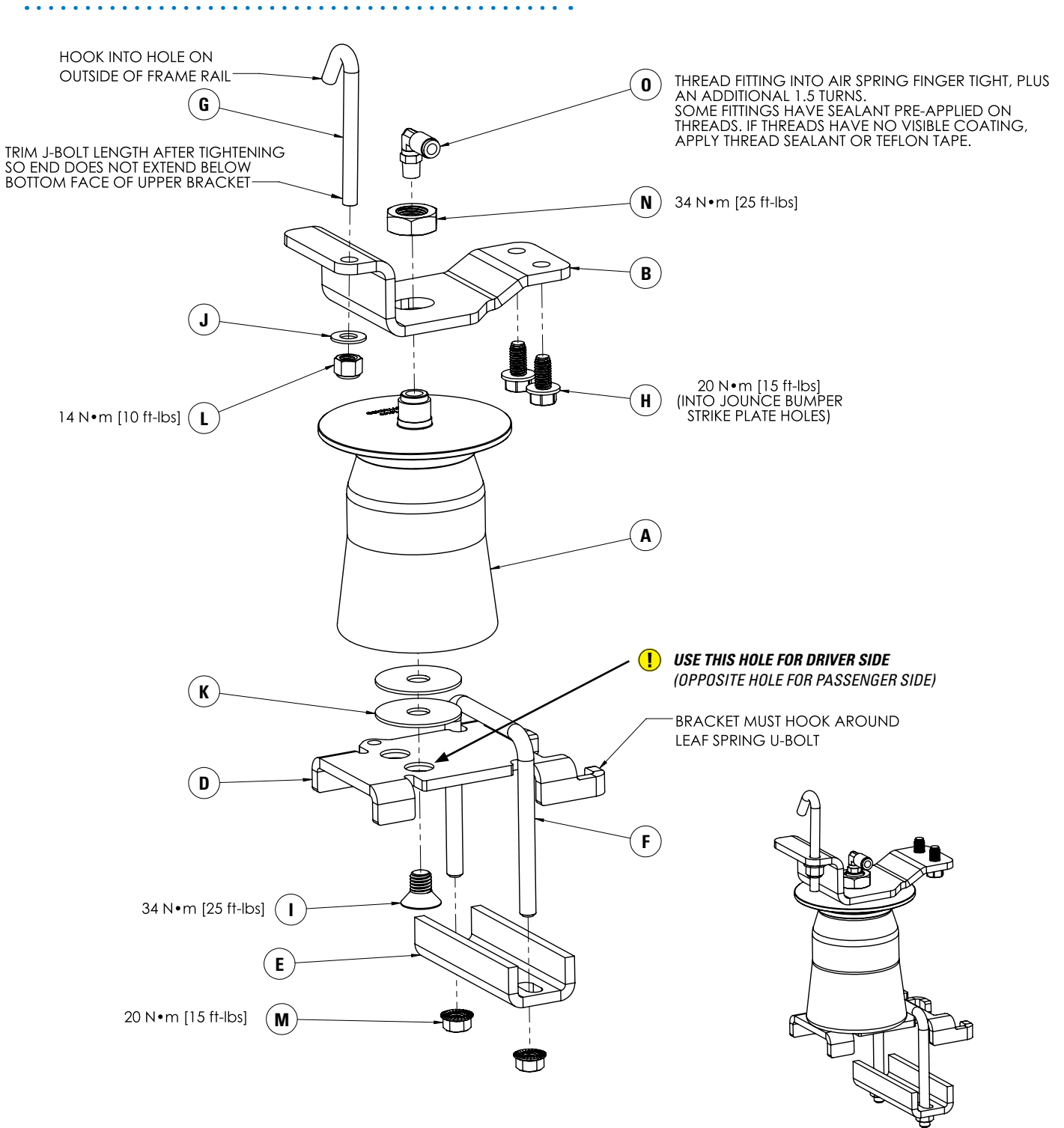

**INSTALLATION INSTRUCTIONS****1 MEASURE STOCK RIDE HEIGHT**

Park the vehicle on a level surface.

Remove any unnecessary weight from the vehicle to attain a Normal Ride Height.

This is important for correct initial air spring set-up and adjustment.

Using a measuring tape, measure the distance between the center of the wheel hub and the bottom of the fender well (as shown in Figure 1) this will give you your ride height.

Note the ride height for all four corners.

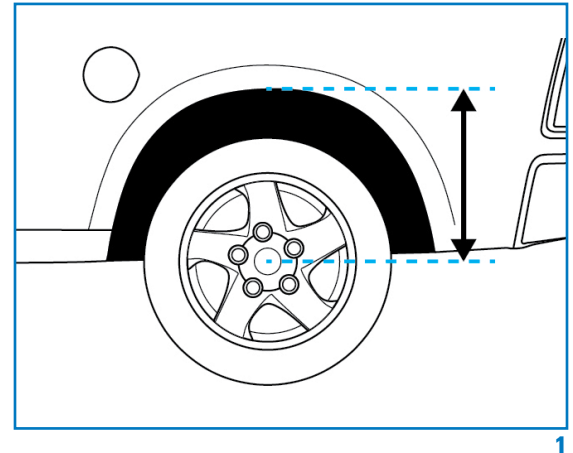

1

**2 REMOVE REAR WHEELS**

Place wheel chocks in front of and behind both front wheels.

Raise the rear of the truck high enough to remove both wheels and attain a comfortable working height.

Place two jack stands under rear axle (shown in Figure 2).

Lower the vehicle until the axle is supported by the jack stands.

Remove rear wheels.

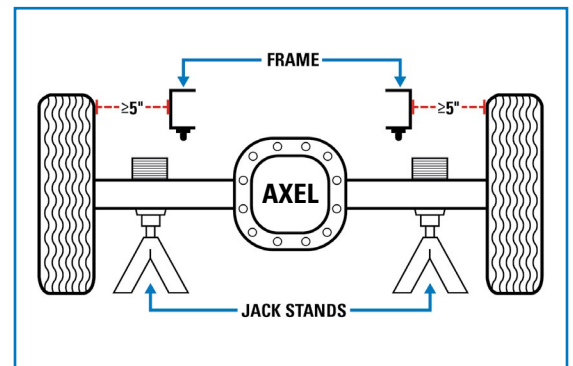

2

### 3 ASSEMBLE THE AIR SPRING

Place the Driver Side upper bracket (HP1566) on top of the air spring and secure with jam nut.

Torque jam nut to 34 N•m (25 ft-lbs)

Install the 90° swivel air fitting into the air spring, finger tight, then tighten an additional 1 to 1.5 turns.

#### Turn over the air spring assembly.

Place two 1/2" flat washers over the hole in the bottom of the air spring.

Then (using Figure 3B as reference), line up the "Driver Side" hole in the lower bracket (shown with a black arrow) and secure it with a flat socket head bolt.

Torque bolt to 34 N•m (25 ft-lbs).

- ⊕ Ensure the edges of the upper and lower brackets are parallel and oriented as shown in Figure 3A.

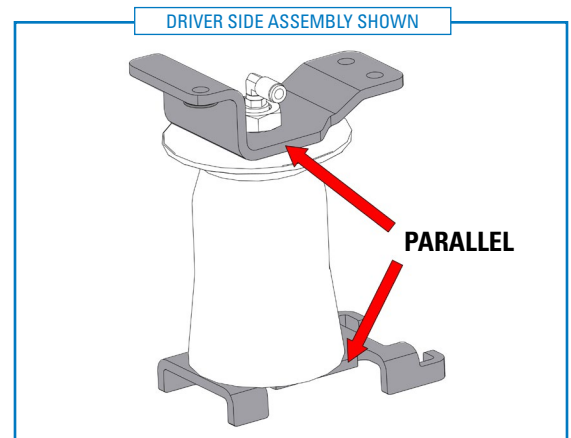

3A

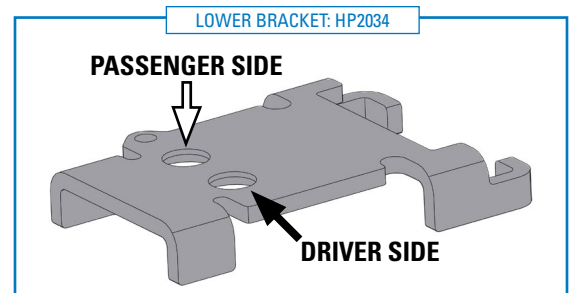

3B

#### REPEAT FOR SECOND AIR SPRING with Passenger Side upper bracket (HP1567)

- ⚠ **PLEASE NOTE:** Passenger Side lower bracket uses the opposite hole from the one used on the Driver Side. (Passenger side shown with a white arrow in Figure 3B).

### 4 PREPARE JOUNCE BUMPER STRIKE PLATE

Locate 8mm holes in each jounce bumper strike plates on each side, on underside of frame rail.

Thread self-tapping bolt into 8mm hole until bolt head is approximately 1/4" from strike plate.

Once complete, remove bolt.

Repeat for the remaining 8mm holes.

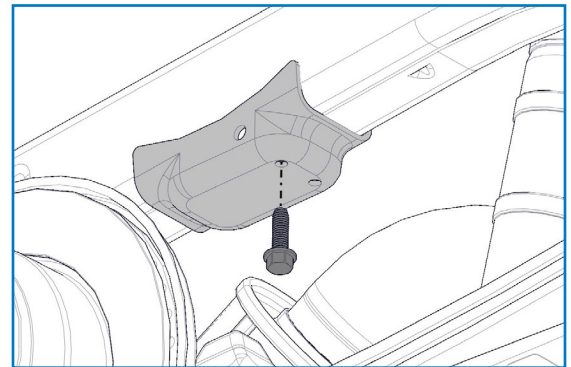

4

### 5 RELOCATE E-BRAKE CABLE

Relocate passenger e-brake cable from upper loop to lower loop of bracket.

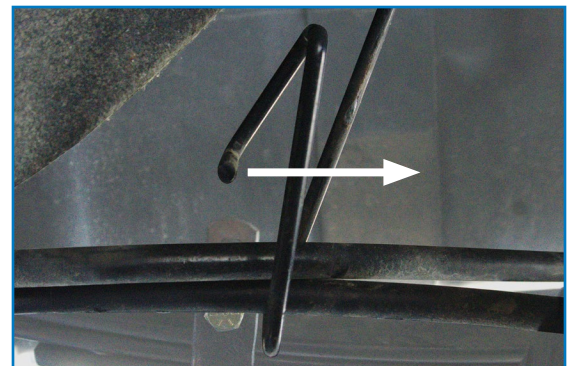

5

## 6 INSTALL AIR SPRING ASSEMBLY

Compress the air spring assembly by hand as needed to fit between the top of leaf spring and frame.

The air spring should sit forward of the axle, with the lower bracket hooked around the leaf spring U-bolt (as shown in Figure 6A).

Place the square U-bolt over the lower bracket and leaf springs.

Install the clamp and secure with flange nuts.

Torque to 20 N•m (15 ft-lbs)

Trim the ends of the U-bolt that extend past nut.

Hook the J-bolt into the opening on outside of the frame rail, install the washer and thread on the Nyloc nut, but do not tighten.

Lightly coat the self-tapping bolts with anti-seize compound and insert through the upper bracket to secure it to strike plate/frame (as shown in Figure 6B).

Torque self-tapping bolts to 20 N•m (15 ft-lbs)

Torque Nyloc nut on J-bolt to 14 N•m (10 ft-lbs)

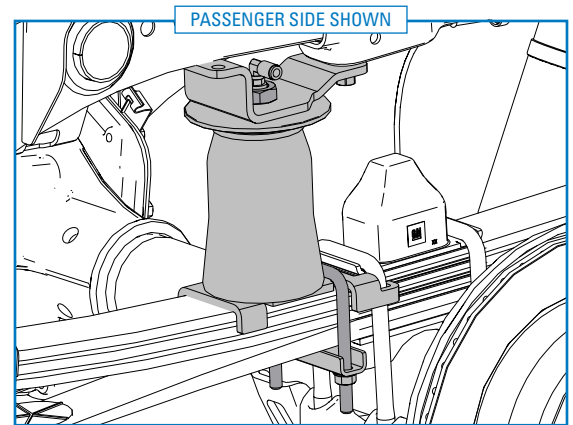

6A

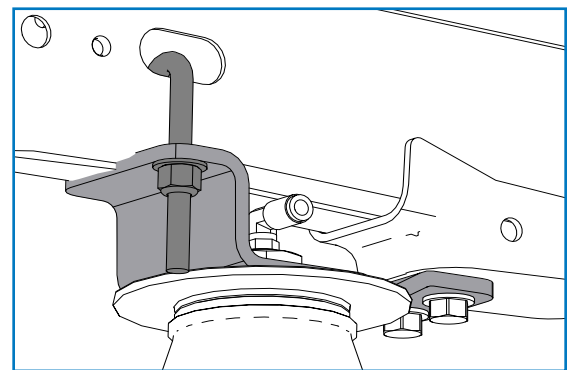

6B

**REPEAT for the opposite side**

## 7 SECURE E-BRAKE CABLE

Loosely secure the passenger e-brake cable to the lower bracket on driver side using tie strap (as shown in Figure 7).

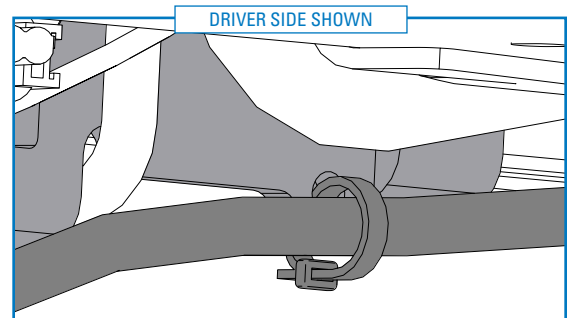

7

## 8 INSTALL HEAT SHIELD

Bend the tabs on heat shield so that there will be the necessary 1/2" dead space between the heat shield and the exhaust when the heat shield is attached.

Attach the heat shield to exhaust pipe using the supplied worm gear clamps.

Each hose clamp holds a bent tab against the exhaust pipe.

Ensure heat shield faces toward the air spring (as shown in Figure 8).

- ⊕ **Diesel model exhaust shown as the example.**  
**Gas model's will mount the heat shield in similar location.**



8

## INSTALL AIR LINE

Two fill valves are provided in this kit. The most common place to install them is in place of the license plate fasteners. Alternatively, two 5/16" holes can be drilled in a location of your choosing.

Cut the air line assembly into two equal lengths with the hose cutter provided in this kit or a sharp utility knife.

**!** **PLEASE NOTE:** *This kit contains push-to-connect fittings; using scissors or wire cutters to cut the nylon air line will distort the line and cause the connection to leak. The air line must be cut off squarely with a hose cutter or a sharp utility knife.*

Install one air line at a time starting at the fill valve location. Place a 5/16" nut on the air valve. Leave enough of the inflation valve in front of the nut to extend through the hole, install a flat washer, and 5/16" nut and cap (reference Figure A for assembly). There should be enough valve exposed after installation – approximately 1/2" – to easily apply a pressure gauge or an air chuck.

Route the air line back to the NPT fitting on the air spring, then cut the hose to length. Moisten the end of the air line prior to inserting it into the fitting and push it in until it stops.

**Repeat with the other fill valve.**

Secure the air lines using the provided tie-straps, away from any moving items and heat sources.

## CHECK SYSTEM FOR LEAKS

Inflate both air springs to 90 psi (60 psi for in-coil bags), then use a mixture of dish soap and water on all air line connections to detect any air leaks. Large, expanding bubbles indicate a leak (as shown in Figure B).

**Repair as necessary and retest.**

Inflate air springs to a predetermined value and on following day recheck pressure. If one or both of air springs have lost pressure, an air leak is present.

**!** **Leak must be repaired, and then retested until no leaks exist.**

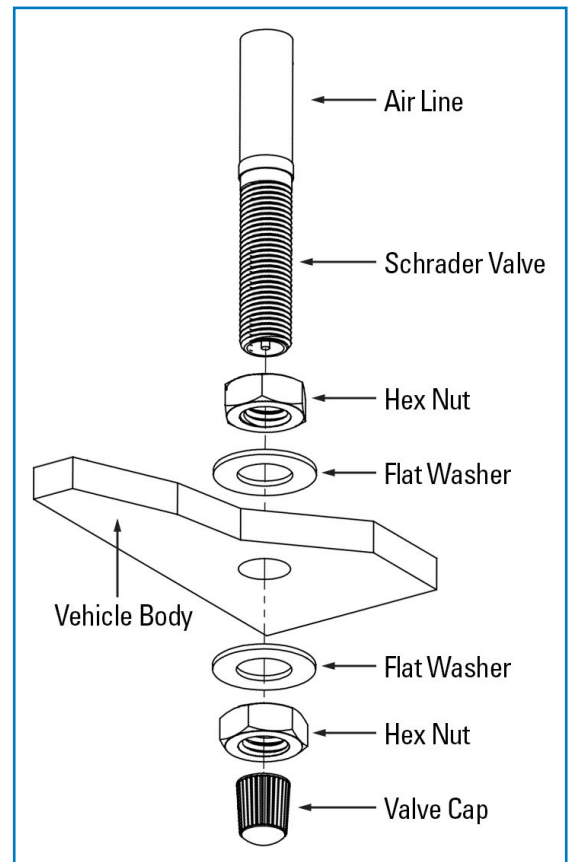

A

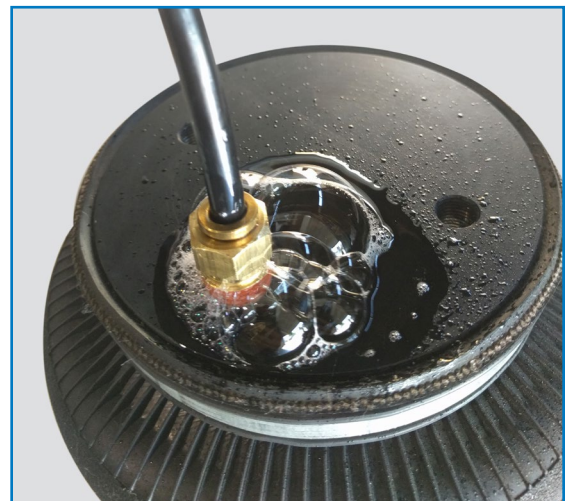

\*Air Spring & NPT Air Fitting may differ between kits

B

**CONGRATULATIONS! You have completed the install**

**After Installation continues on the following page.**



**Thank you again, and congratulations on the installation of your Air Suspension kit.**

**AFTER COMPLETING THE INSTALLATION**

- The air spring must have clearance between itself and the surrounding components to prevent any contact when spring is inflated or compressed. Trimming off excess bolt length may also be required to ensure no contact with the spring or other suspension components can be made once installed.
- If removed, re-install the wheels and torque fasteners to the manufacturer’s specifications. Re-torque all fasteners after the first 500 miles of driving.

**OPERATING YOUR VEHICLE WITH AIR SUSPENSION**

Air springs have minimum and maximum recommended pressure requirements:

PART #	SPRING STYLE	SPRING TYPE	MIN PSI	MAX PSI
HP10189	In-Coil	STANDARD DUTY	5 PSI	70 PSI
HP10560		STANDARD DUTY		
HP10001	Sleeve Style	STANDARD DUTY	10 PSI	100 PSI
HP10173		STANDARD DUTY		
HP10199		STANDARD DUTY		
HP10083	Single Convoluted	HEAVY DUTY	5 PSI	100 PSI
HP10083J		HEAVY DUTY with JOUNCE BUMPER	0 PSI* / 5 PSI	100 PSI
HP10000	Double Convoluted	HEAVY DUTY	5 PSI	100 PSI
HP10000J		HEAVY DUTY with JOUNCE BUMPER	0 PSI* / 5 PSI	100 PSI
HP10068	Large Double Convoluted	HEAVY DUTY	5 PSI	100 PSI
HP10438	Double Convoluted	EXTREME DUTY	5 PSI	100 PSI
HP10438J		EXTREME DUTY with JOUNCE BUMPER	0 PSI* / 5 PSI	100 PSI

*\* Springs with a jounce bumper can be run at zero PSI when vehicle is unloaded only*

For safe and proper operation, never operate the vehicle over the maximum listed PSI in the air springs. Staying under the pressure limit will ensure maximum air spring life. **Failure in doing so may result in damage to your vehicle and/or a void warranty.**

**! It is recommended to check the air pressure in your air springs daily for first couple of days to ensure a leak has not developed.**

Air springs are designed to maintain the vehicle’s stock ride height with a load. Do not use the air springs as a means to lift vehicle with no load. This will result in a harsh ride.

**SERVICING YOUR VEHICLE WITH AIR SUSPENSION**

When lifting the vehicle with a floor jack or hoist on the frame, never allow the air spring to limit the travel of the axle. Try to always jack the vehicle on the axle. Suspending the axle with the air spring limiting the axle travel will damage the air spring and void the air spring warranty.

**WARRANTY**

**See additional warranty included with this kit for details.**