

# Installation Manual



## 10655 KIT

**2.5" Leveling Kit** Ford Ranger (2WD/4WD)\*  
*Excludes Tremor*

*Levels the stance of your vehicle by raising the front end a fixed amount, increasing both the ground and wheel well clearance for the installation of larger wheels.*

\* See application guide for proper fitment.

L6602\_REV1\_10.17.2023\_ECN 1-2829

**Thank you and congratulations on the purchase of a Leveling Kit. Please read the entire manual prior to starting the installation to ensure you can complete it once started.**

**KIT LAYOUT**



**KIT CONTENTS**

*Please make sure all the items shown in the above kit layout are provided in your kit before starting the installation.*

KIT CONTENTS		QTY	PART #
<b>A</b>	Upper Strut Mount Spacer	2	HP2024
<b>B</b>	Stud, M10 - 1.5 mm x 45 mm	6	HP1547
<b>C</b>	Flange Nut, M10 - 1.5 mm	6	HP1457

**REQUIRED TOOLS**

- Hoist or Floor Jack
- Safety Stands
- Safety Glasses
- Torque Wrench
- Standard Combination Wrenches
- 7/32" Hex Allen Wrench
- 1-1/8" Wrench or Deep Socket
- Metric & Standard
- Sockets Ratchet

**Please make sure all the items shown in this explosion diagram and in the kit contents on the previous page are provided in your kit before starting the installation.**

## KIT ASSEMBLY SHOWN:

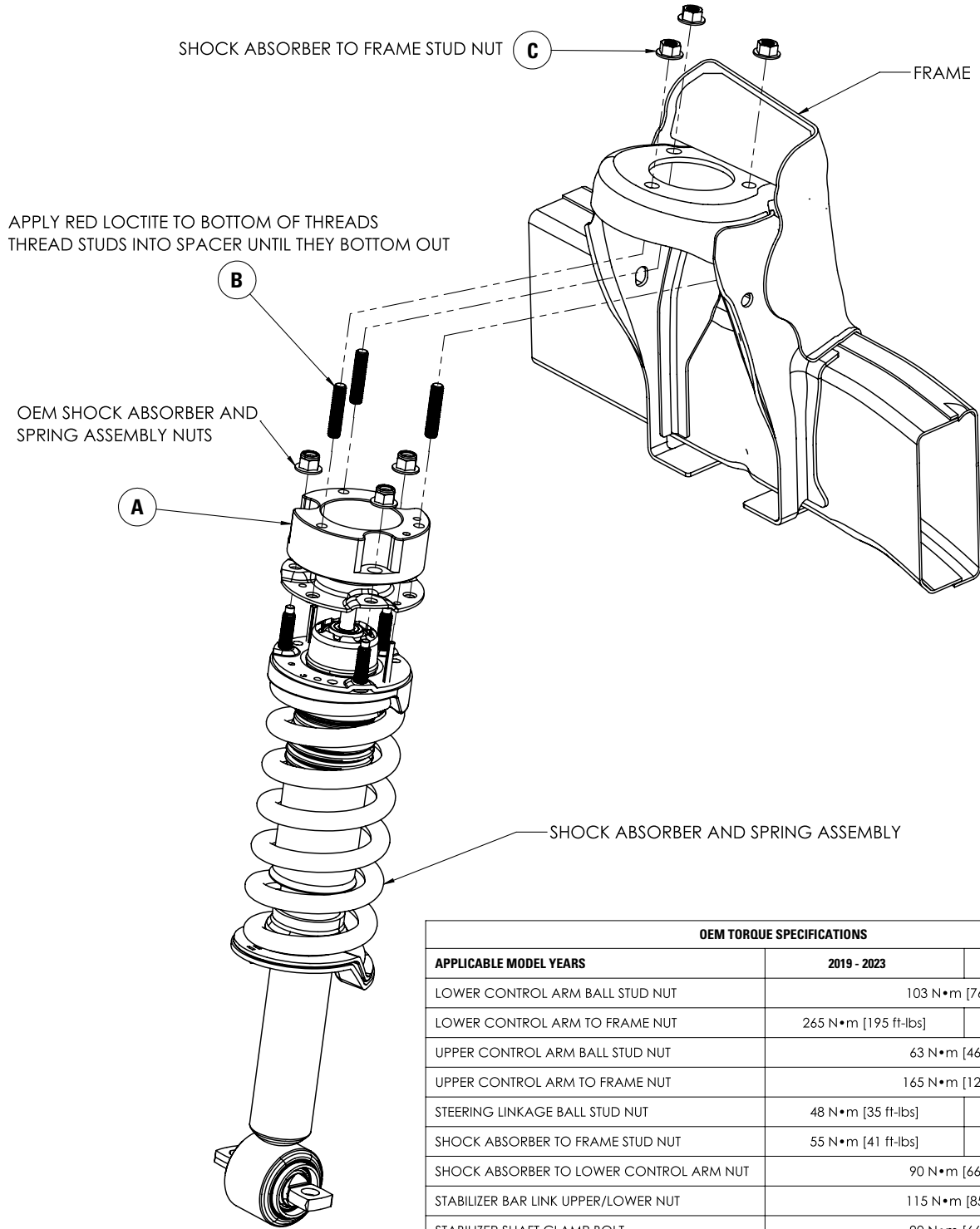

OEM TORQUE SPECIFICATIONS		
APPLICABLE MODEL YEARS	2019 - 2023	2024
LOWER CONTROL ARM BALL STUD NUT	103 N•m [76 ft-lbs]	
LOWER CONTROL ARM TO FRAME NUT	265 N•m [195 ft-lbs]	285 N•m [210 ft-lbs]
UPPER CONTROL ARM BALL STUD NUT	63 N•m [46 ft-lbs]	
UPPER CONTROL ARM TO FRAME NUT	165 N•m [122 ft-lbs]	
STEERING LINKAGE BALL STUD NUT	48 N•m [35 ft-lbs]	30 N•m [22 ft-lbs]
SHOCK ABSORBER TO FRAME STUD NUT	55 N•m [41 ft-lbs]	63 N•m [46 ft-lbs]
SHOCK ABSORBER TO LOWER CONTROL ARM NUT	90 N•m [66 ft-lbs]	
STABILIZER BAR LINK UPPER/LOWER NUT	115 N•m [85 ft-lbs]	
STABILIZER SHAFT CLAMP BOLT	90 N•m [66 ft-lbs]	
BRAKE HOSE BRACKET TO KNUCKLE BOLT	18 N•m [159 in-lbs]	25 N•m [18 ft-lbs]

**BEFORE STARTING THE INSTALLATION:**

*Safety Warning!*

Altering the suspension system of your vehicle may cause it to handle differently than it did from the factory. Larger wheel and tire combinations may increase the leverage on the suspension and steering components. This changes the way your vehicles handles and responds to abrupt maneuvers. Operate your vehicle at reduced speeds in all conditions to prevent loss of control. Failure to do so may result in serious injury. It is not recommend to combine the use of suspension lifts, body lifts, or other lifting methods.

*Installation Warning!*

Use caution when disassembling and reassembling the vehicle. The proceeding instructions are guidelines only, the installer is responsible for ensuring that the vehicle is safe for use after performing the installation. It is recommended to use the factory service manual for the model/year of the vehicle when disassembling and assembling factory related components.



Ford recommends discarding factory fasteners removed from specific suspension components and replacing them with new Ford nuts. This manual recommends discarding factory nuts removed from specific suspension components and replacing them with new Ford fasteners or the fasteners provided in this kit.

Suspension components that use rubber or urethane bushings should be tightened with the vehicle at normal ride height. This will prevent premature wear or failure of the bushing. Prevent the suspension components from overextension by supporting them with a jack.

**PLEASE NOTE:** Due to the suspension geometry and vehicle tolerances, the amount of lift is a base figure. **Spacer thickness does not equate to the amount of lift due to the suspension geometry.** For example: a 1" thick spacer may provide a 2" lift. Always measure the vehicle ride height at all 4 corners before and after installation to ensure the results are as expected.

**WHEEL ALIGNMENT AND HEADLIGHT ADJUSTMENT**

It is necessary to have a proper and professional wheel alignment performed by a certified alignment technician to align the vehicle to factory specifications. After the installation is complete, check to ensure that the vehicle's headlights are aimed properly. If not, a headlight alignment is required.

**SENSOR RECALIBRATION REQUIRED FOR ADAS**

Manufacturer sensor recalibration procedure is required for vehicles equipped with Advanced Driver Assistance System (ADAS). ADAS may not operate as intended if calibration is not performed.



## 1 MEASURE STOCK RIDE HEIGHT

Park the vehicle on a level surface.

Using a measuring tape, measure the distance between the center of the wheel hub and the bottom of the fender well (as shown in Figure 1) this will give you your ride height.

Note the ride height for all four corners.

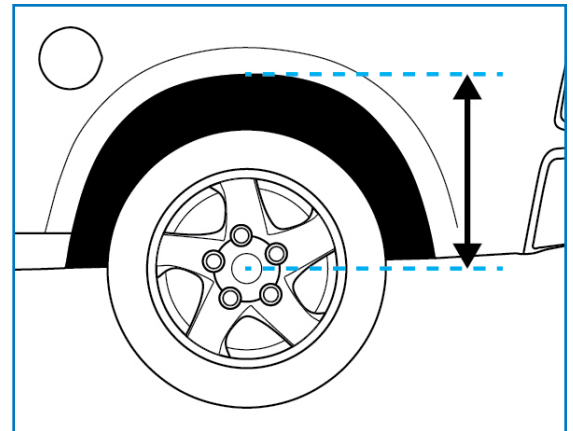

1

## 2 REMOVE FRONT WHEELS

Place wheel chocks in front of and behind both rear wheels.

Raise front of the truck high enough to remove both wheels and attain a comfortable working height.

Place two jack stands under the vehicle's frame.

Lower the vehicle until the frame is supported by the jack stands.

Remove the front wheels.

## 3 REMOVE STEERING SKID PLATE

Loosen the two front skid plate bolts – but **do not remove bolts**.

Remove the two rear skid plate bolts.

Slide out skid plate and set aside.

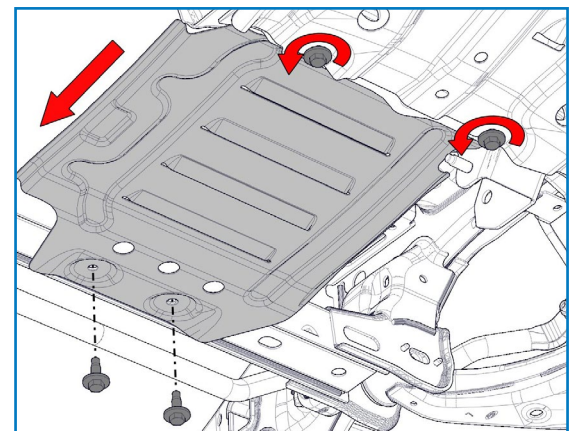

4

## 4 UNPLUG ELECTRONIC POWER STEERING

Unplug the three power steering plugs, allowing to hang loose (as shown in Figure 4)

## 5 DETACH SWAY BAR MOUNTS

Remove the sway bar mounting bolt and nut on each side of the vehicle (as shown in Figure 5).

Allow sway bar to hang freely.

## 6 SUPPORT LOWER CONTROL ARM

Place the floor jack under the lower control arm, near ball joint.

Jack it up to slightly compress the suspension.

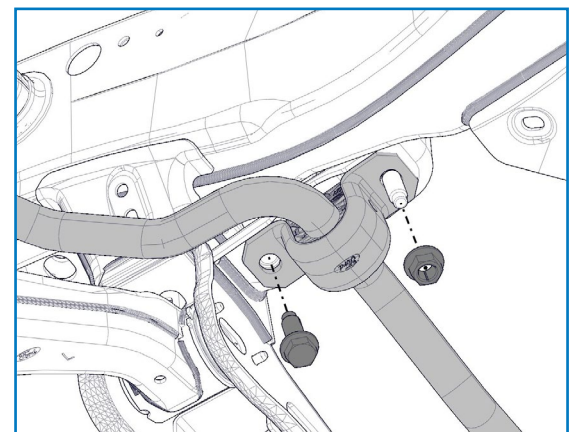

5

## 7 DETACH ABS SENSOR, ABS WIRE & BRAKE LINE BRACKETS

(Using Figure 7 as reference) Remove the bolt securing the brake line bracket to the upright.

Remove the bolt securing the ABS bracket to the upright.

Remove the bolt securing the ABS sensor to top of the upright.

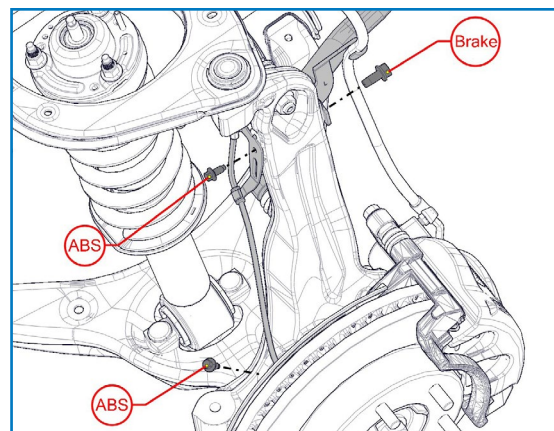

7

## 8 REMOVE TIE ROD END NUT

Using a wrench to stop the ball joint from spinning, remove and discard the tie rod end nut (as shown in Figure 8).

Strike upright to dislodge tie rod end.

## 9 REMOVE UPPER BALL JOINT NUT

Using a wrench to stop the ball joint from spinning, remove and discard upper ball joint nut.

Strike upright to dislodge ball joint.

Once nut is removed, lower upright by lowering jack.

**⚠ Do not remove jack completely as CV joint can pull out.**

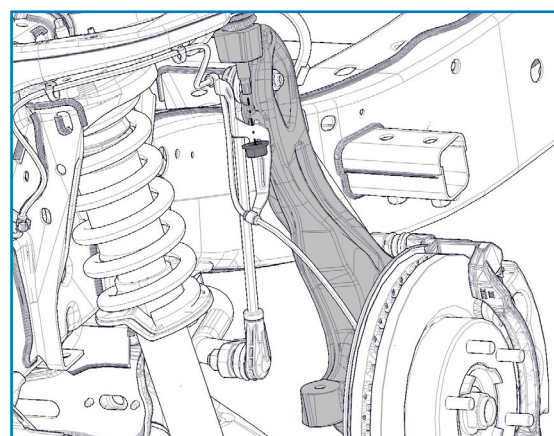

8

## 10 REMOVE LOWER STRUT MOUNT NUTS

Remove the two nuts securing the lower control arm to the lower strut mount cross pin. (See Figure 10)

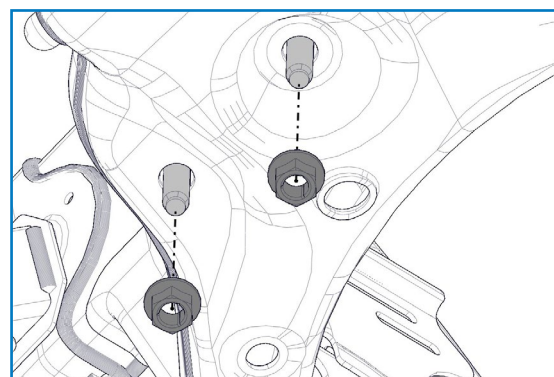

10

**11 REMOVE UPPER STRUT MOUNT NUTS**

Remove the three upper strut mount nuts. (See Figure 11)

**12 REMOVE STRUT ASSEMBLY**

Remove the strut assembly from the vehicle.

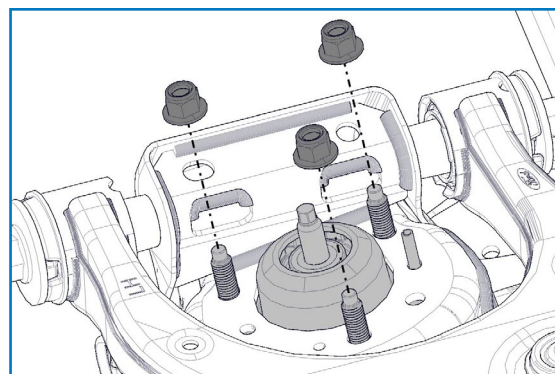

11

**13 INSTALL STUDS INTO BILLET STRUT SPACER**

Put a small amount of red thread locker on the bottom threads of the three M10 studs.

Thread the studs into the spacer until they bottom out.

**PLEASE NOTE:** Approximately 22mm will protrude above the spacer.

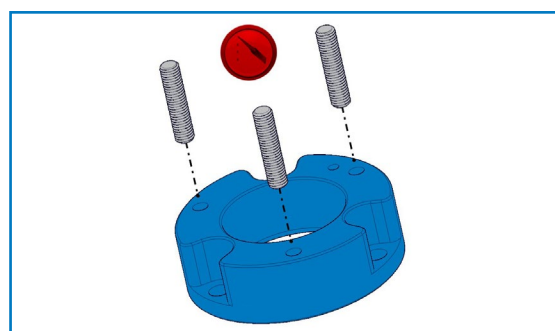

13

**14 INSTALL BILLET STRUT SPACER**

Attach billet strut spacer to top of factory strut assembly using the three factory nuts (as shown in Figure 14).

Torque the three nuts to the OEM torque specs (found on Page 3) for '**Shock Absorber to Frame Stud Nut**' depending on your vehicle's model year.

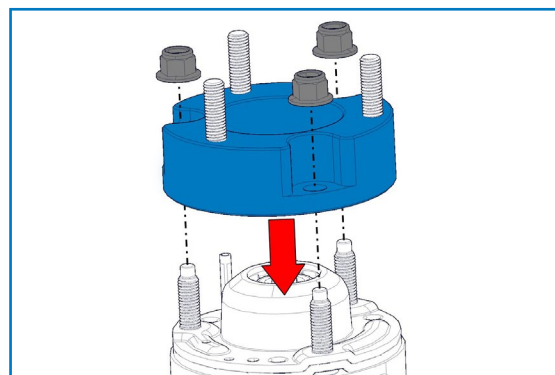

14

**15 REMOVE LOWER STRUT MOUNT STUDS**

Clamp lower strut mount cross pin in vise. Thread factory nuts on a few threads by hand.

Use hammer to knock studs out of cross pin.

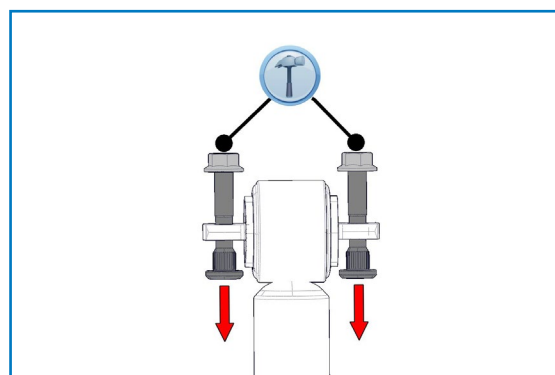

15

## 16 REINSTALL STRUT ASSEMBLY

Attach strut assembly (with billet spacer installed) to frame using three supplied M10 nuts. Tighten nuts hand-tight.

## 17 REINSTALL LOWER STRUT MOUNT STUDS

Reinstall the two factory studs through cross pin and lower control arm. Tap with a hammer to seat splines.

Reinstall the two factory nuts and torque to the OEM torque specs (found on Page 3) for **'Shock Absorber to Lower Control Arm Nut'**.

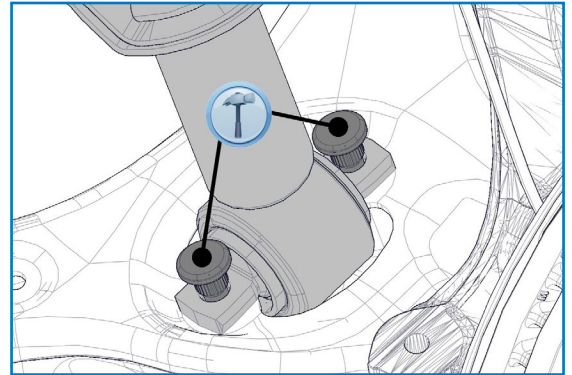

17

## 18 TORQUE UPPER STRUT MOUNT NUTS

Torque the 3 upper strut mount nuts to the OEM torque specs (found on Page 3) for **'Upper Control Arm to Frame'**.

## 19 CONNECT UPPER BALL JOINT

Insert upper ball joint into upright, install M12 flat washer and supplied M12 nut by hand.

Torque nut to the OEM torque specs (found on Page 3) for **'Upper Control Arm Ball Stud Nut'**.

## 20 CONNECT TIE ROD END

Insert tie rod end into upright, install M10 flat washer and supplied M10 nut by hand.

Torque nut to the OEM torque specs (found on Page 3) for **'Steering Linkage Ball Nut'** depending on your vehicle's model year.

## 21 REATTACH ABS SENSOR, ABS WIRE & BRAKE LINE BRACKETS

Reinstall factory bolt to secure brake line bracket to upright. Torque to the OEM torque specs (found on Page 3) for **'Brake Hose Bracket to Knuckle Bolt'** depending on your vehicle's model year.

Reinstall factory bolt to secure ABS wire bracket to upright. Torque to the OEM torque specs (found on Page 3) for **'Brake Hose Bracket to Knuckle Bolt'** depending on your vehicle's model year.

Reinstall factory bolt to secure ABS sensor to top of upright. Torque to the OEM torque specs (found on Page 3) for **'Brake Hose Bracket to Knuckle Bolt'** depending on your vehicle's model year.

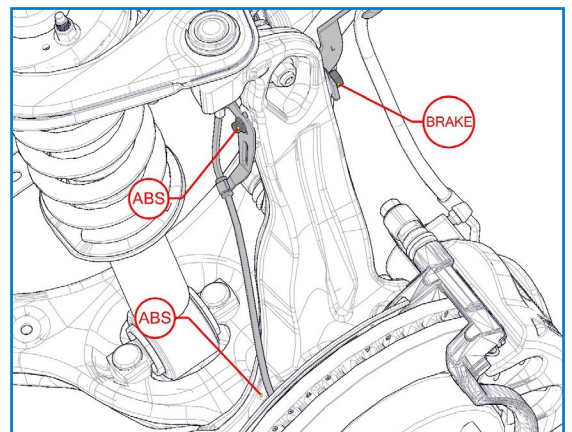

21



**22 REPEAT FOR OPPOSITE SIDE**

*Repeat Steps 6 through 21 for opposite side.*

**23 REATTACH SWAY BAR MOUNTS**

Install sway bar mounting bolt and nut on each side of vehicle.

Torque to bolt to the OEM torque specs (found on Page 3) for '*Stabilizer Shaft Clamp Bot*'.

Torque to nut to the OEM torque specs (found on Page 3) for '*Stabilizer Bar Link Upper/Lower Nut*'.

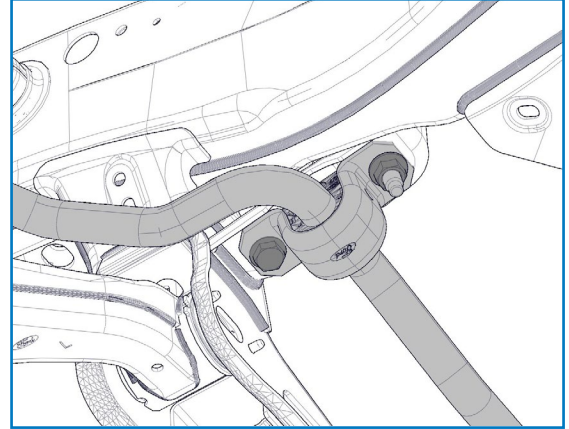

23

**24 PLUG IN ELECTRONIC POWER STEERING**

Plug in the three power steering plugs.

**25 REINSTALL STEERING SKID PLATE**

Slide skid plate onto the two front skid plate bolts.

Reinstall the two rear skid plate bolts and tighten till secured.

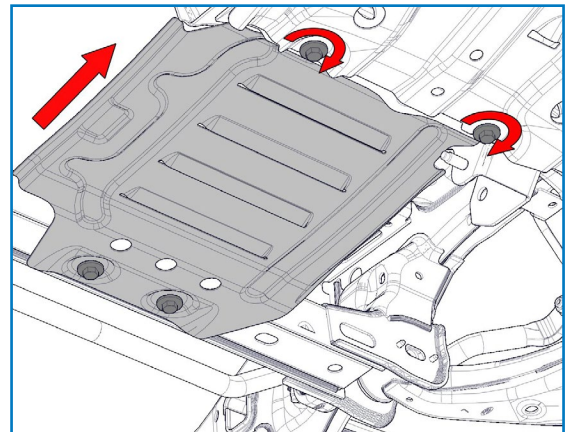

25

**26 REINSTALL WHEELS**

Install wheels and torque them to factory specification.

Raise vehicle, remove jack stands from under frame and lower vehicle back to ground.

Roll vehicle forward and backwards, and bounce vehicle up and down several times to stabilize suspension.

***Congratulations! You have completed the installation***

**POST INSTALLATION WARNING**

After the kit installation is complete and the vehicle is on the ground at its normal ride height, roll the vehicle backward and forward to settle the suspension. Tighten all components containing rubber bushings to the specified torque values. Verify adequate tire, wheel, brake line and ABS wire clearance by turning the front wheels completely to the left and then to the right. Ensure brake/ABS lines are not stretched when the suspension is at full droop. Test and inspect steering, brake and suspension components. Vehicle damage may result if the post installation checks are not performed.

**VEHICLE HANDLING WARNING**

Larger wheel and tire combinations may increase the leverage on the suspension and steering components. Increasing the height of your vehicle increases the likelihood of rollover or loss of control during abrupt maneuverer, especially at high speeds. Operate your vehicle at reduced speeds in all conditions to prevent loss of control. Failure to do so may result in serious injury.

**WHEEL ALIGNMENT & HEADLIGHT ADJUSTMENT**

After the kit installation is complete, a professional wheel alignment must be performed by a certified alignment technician to re-align the vehicle to within factory specifications. Additionally, ensure that the vehicles headlights are aimed properly. If not, a headlight alignment is required as well. If not properly aligned it can cause increased tire and suspension component wear.

**SENSOR RECALIBRATION REQUIRED FOR ADAS**

Manufacturer sensor recalibration procedure is required for vehicles equipped with Advanced Driver Assistance System (ADAS). ADAS may not operate as intended if calibration is not performed.

**VEHICLE RE-TORQUE & SAFETY INSPECTION**

After the kit installation and adjustments have been completed and within 50 miles of driving, perform a check over of all applicable fasteners and hardware to ensure they are adequately tightened to the specifications given (or as noted in the vehicle's factory service manual).

**WARRANTY**

To be eligible for warranty, the owner must submit their warranty card or register online within 30 days of the purchase date.

