

Installation Manual

VERSION
FRANÇAISE

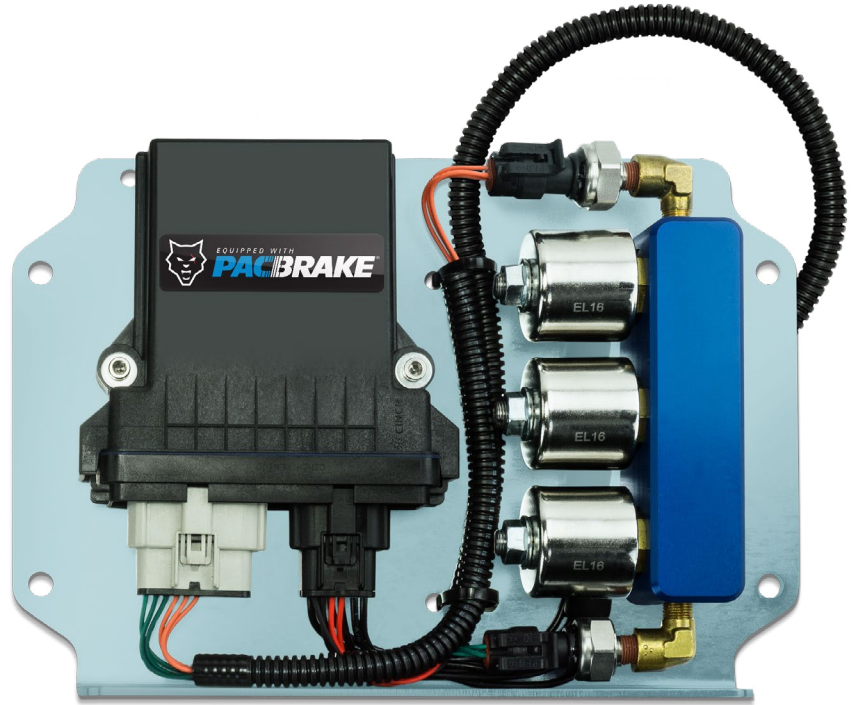

DUAL CHANNEL WIRELESS CONTROLS

20325 Wireless Air Spring & Onboard Air Controls Kit
*Requires Air Springs and an Onboard Air System
(sold separately)*

Giving you the ability to adjust your air spring pressure from your phone with the touch of a button. It's the perfect means to control your vehicle's air suspension system from inside or outside your vehicle!

Thank you & congratulations on the purchase of a Wireless Air Spring Control Kit.

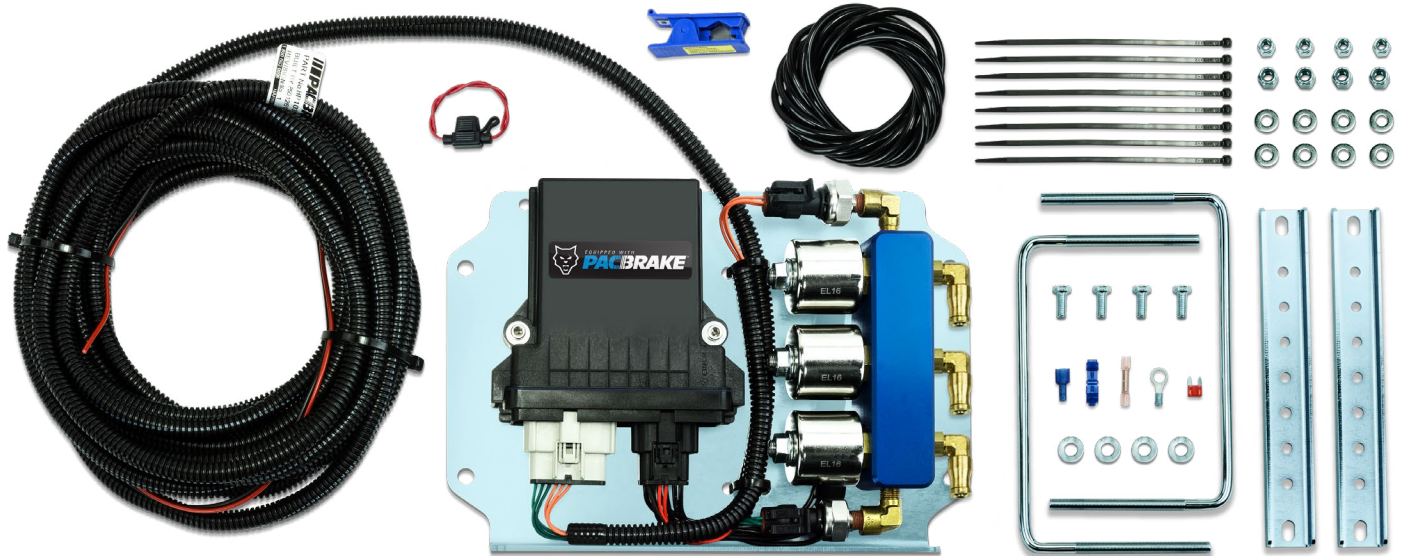

KIT CONTENTS

Please make sure all the items listed below are provided in your kit before starting the installation.

KIT CONTENTS	PART #	QTY
▶ Wireless Control Board Assembly	HP10326	1
▶ Frame Bracket	HP1515	2
▶ U-Bolt — 3/8" -16" x 5.5" x 9.5"	HP1511	2
▶ Hex Head Screw — 5/16" -18 x 3/4	C11729	4
▶ Nyloc Nut — 3/8" -16	HP1000	4
▶ Nyloc Nut — 5/16" -18	C11943	4
▶ Flat Washer — 3/8"	C653	4
▶ Flat Washer — 5/16" x 3/4	HP1259	8
▶ Fuse, 10A	M8172	1
▶ Fuse Holder	M6083	1
▶ Ring Terminal	M8047	1
▶ Spade Terminal	M8115	1
▶ Heat Shrinkable Splice	M8112	1
▶ T-Tap —16-14 AWG	M8108	1
▶ Nylon Airline Tubbing — 1/4"	M3280-30	30'
▶ Tube Cutter	HP10208	1
▶ Zip Ties	C11618	16

REQUIRED TOOLS

- Wire Strippers
- Terminal Crimper
- Heat Gun or Torch
- Ratchet and Socket Set
- Multi Meter or Test Light
- Torque Wrench
- Tube Cutter (included) or Sharp Utility Knife

SYSTEM DIAGRAM: 20325

Please make sure all the items shown in the kit contents on Page 2 are provided in your kit before starting the installation.

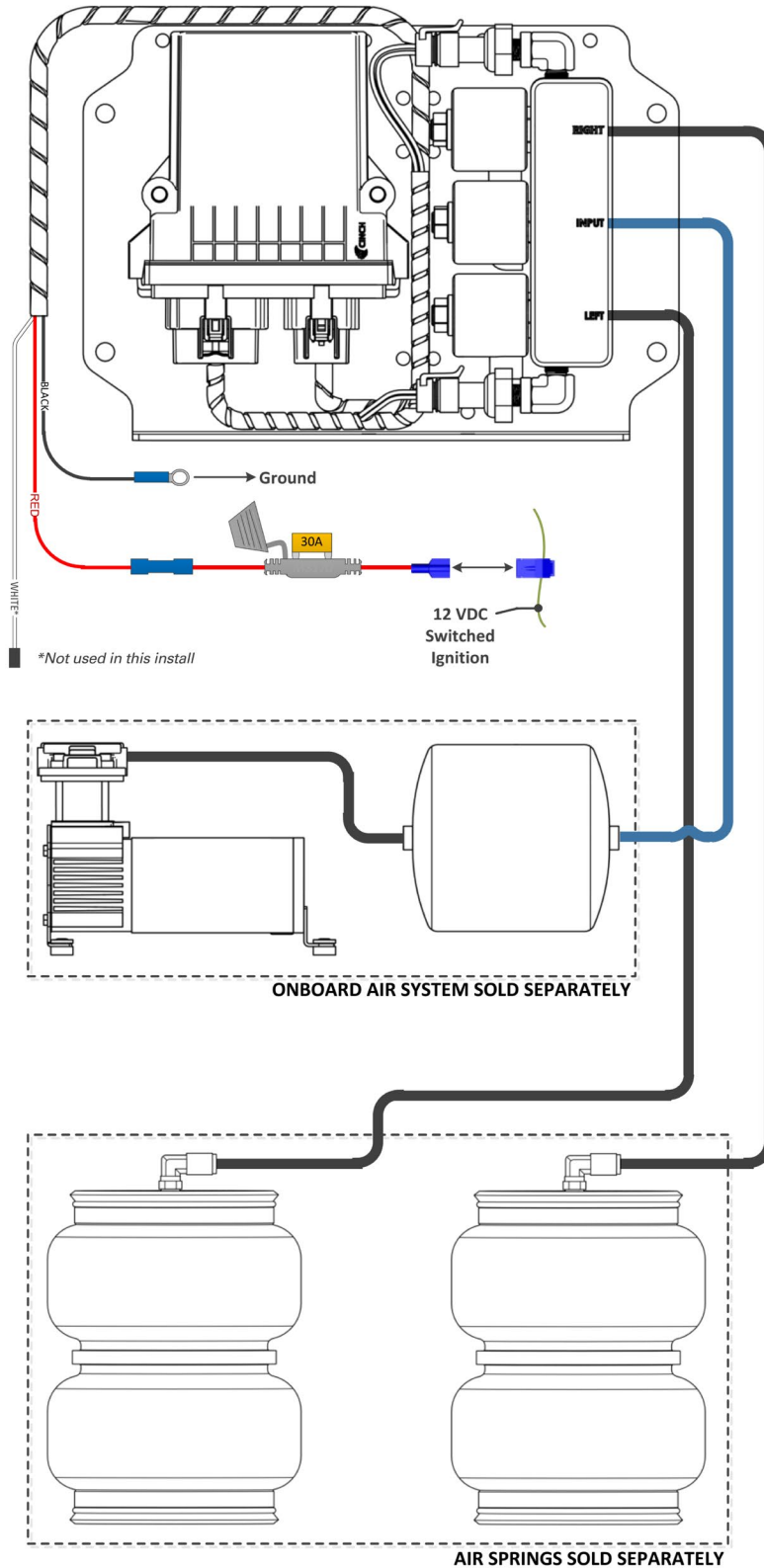

BEFORE STARTING THE INSTALLATION:

1. Read through this manual and ensure you can complete the installation once started.
2. It is recommended to use a good quality anti-seize on all fasteners. This will reduce the chance of corrosion on the fasteners and will help facilitate removal, if required at a later date.

PLEASE NOTE:

Using scissors or wire cutters to cut the nylon airline will distort the line and cause the connection to leak. THE AIRLINE MUST BE CUT OFF SQUARELY WITH THE NYLON HOSE CUTTER OR A SHARP UTILITY KNIFE.

3. This Wireless Air Spring Controls will only work on systems with a MAX of 150psi.

Visit www.pacbrake.com/mm5/pdfs/L8025.pdf for product specifications.

1 CONTROL BOARD INSTALLATION

This kit is designed to be installed along the frame rail of pickup trucks, (as shown in Figure 1A).

Check for clearance along the frame rail to ensure that the kit will not interfere with anything once installed.

Fasten the control board to the two frame brackets using the supplied 5/16" hex head cap screws, nuts and washers. (Refer to Figure 1B)

Torque the hardware to 23 N•m [17 ft-lbs].

Mount the control board as high as possible on the frame rail and in the orientation shown in Figure 1C

⚠ Do NOT mount controller or compressor assembly directly on engine or other components exhibiting harsh vibration

⚠ Do NOT mount the controller or compressor assembly in areas where ambient temperature exceeds 70°C [158°F]

Securely install the control board assembly onto the frame rail of the vehicle using 2 U-bolts, 4 flat washers, and 4 nyloc nuts. (Refer to Figure 1C for configuration and assembly).

Check to ensure control board and mounting brackets do not pinch or interfere with any vehicle components.

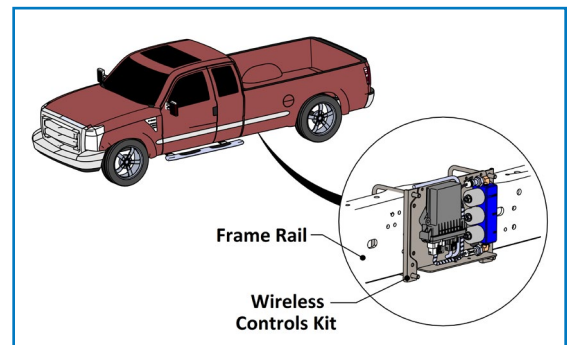

1A

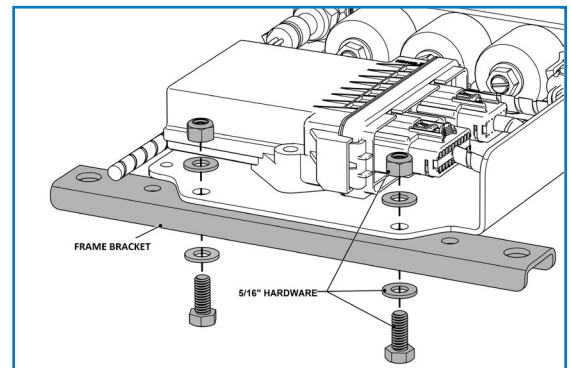

1B

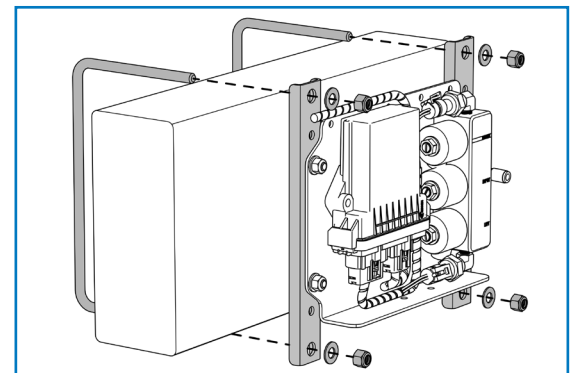

1C

2 CONTROL BOARD HARNESS INSTALLATION

Refer to the system diagram on Page 3 for the following instructions:

Locate a switched ignition wire at the fuse block in the engine bay. Ensure the ignition is OFF before proceeding.

Using Figure 2 (below) as reference, route the red/black harness from the control board to the engine bay. Use the supplied zip ties to secure the harnesses away from all heat sources and moving components. Extend/trim the harness as necessary.

Strip the end of the black wire and crimp the supplied ring terminal to it.

Connect the ring terminal to the negative terminal of the battery.

⚠ *If the negative terminal of the battery is not accessible, an external chassis ground may be used provided it has clean contact.*

Use the blue heat shrinkable splice to connect the fuse holder to the red wire.

Crimp the male spade terminal to the other end of the fuse holder.

Use the blue 16-14 AWG T-tap and crimp it onto a 12VDC switched ignition source, then connect the male spade terminal to the T-Tap.

⚠ *The T-tap can be crimped onto a constant 12VDC source – giving the user the ability to control their air springs without having to power the truck on. The controller consumes approximately 35-80mA in standby mode, which will slowly discharge the battery.*

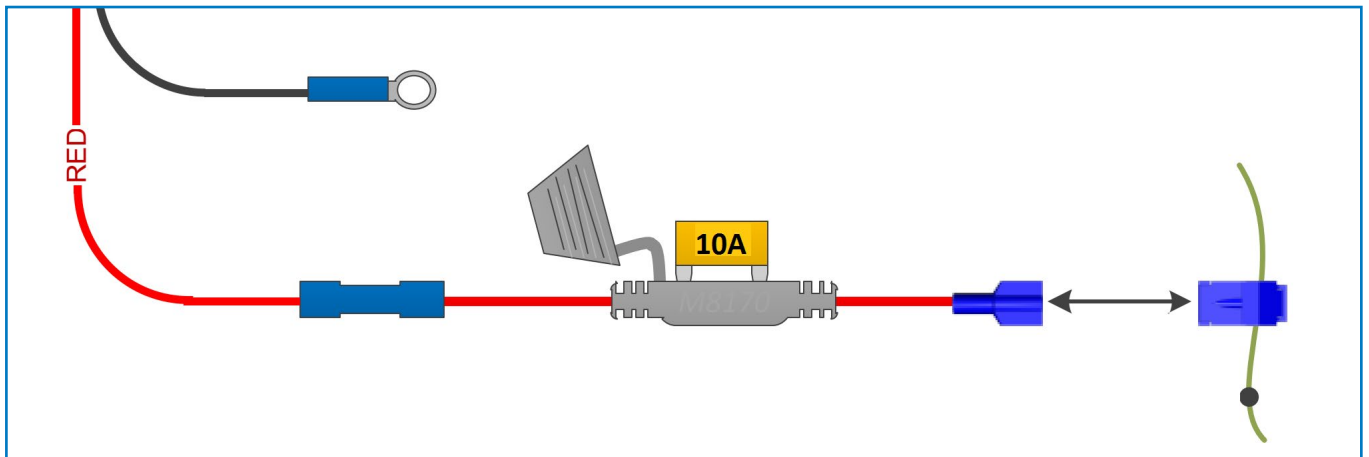

2

3 PLUMBING

Refer to the system diagram on page 3 for the following instructions:

⚠ *Use the supplied tube cutter to cut the airline. Using scissors may distort the line and cause the fitting to leak.*

Connect the input of the solenoid block to the outlet of your onboard air system.

Connect the inlet of the **DRIVER** side air spring to the **LEFT** port on the solenoid block.

Connect the inlet of the **PASSENGER** side air spring to the **RIGHT** port on the solenoid block

Use the supplied zip ties to secure the airlines away from heat sources and moving components

4 APPLICATION USER GUIDE

Download the Wireless Air Controls app on Google Play, the App Store, or visit www.pacbrake.com/wireless to download the latest version.



Once all installation has been completed, the system is ready to be paired with your mobile device.



*Phone not included

4

Pairing/Connecting the Controller with an Android Device:

- Switch vehicle to ignition power or idle engine to power controller
- Ensure that Bluetooth and Location services are turned on
- In system options, open the Bluetooth page
- Refresh and search for the controller with name containing “PACBRAKE”
- Select the controller for pairing – if successful, the Wireless controller will be added to the list of paired devices on your mobile device.
- Open the Wireless Air Spring Controls app. The Bluetooth toggle will illuminate to show if your device has successfully connected to the controller on the Wireless Controls kit.

Pairing/Connecting to Controller with an iPhone™:

- Ensure that Bluetooth and Location services are turned on
- Open the Wireless Air Spring Controls app. The Bluetooth toggle will illuminate to show that your device has successfully connected to the controller on the Wireless Controls kit.

PLEASE NOTE: If multiple Pacbrake app controlled devices are nearby, a window will be displayed to select a controller for connection.

Air Spring Inflation/Deflation

Press and hold the **Inflation** or **Deflation** button to adjust the pressure in the air springs.

Use the Air Spring Selection tab to select which air spring to inflate/deflate.

⚠ *The wireless app does not limit the minimum or maximum pressure in your air springs. Inflate your air springs according to your air spring manufacturer’s guidelines.*

Presets Tab

Use the **Presets Tab** to save pressure presets.

Press and hold one of the preset buttons to save the current pressure value as a preset. A message on the bottom of the screen will indicate that the preset has been saved.

Use these presets anytime to quickly adjust to the desired pressure.

Bluetooth Toggle

The **Bluetooth Toggle** illuminates when it has successfully connected to the wireless controller.

Tap the Bluetooth toggle to manually connect or disconnect from the controller.

NOTE: The app automatically connects to the controller on start-up.

Air Spring Selection

Select which air spring to inflate/deflate by tapping on the **Left**, **Both** or **Right** button.

Pressure Indicator

The Pressure Indicator shows the pressure of each air spring with an accuracy of $\pm 5\%$ over the entire range. The presets allow for rapid adjustment to the desired pressure (± 1 PSI)

5 LEAK TEST

Inflate both air springs to 90 psi (60 psi for in-coil bags) and then use a mixture of dish soap and water on all air line connections to detect any air leaks. Large, expanding bubbles indicate a leak (as shown in Figure 5).

Repair as necessary and retest.

Inflate air springs to a predetermined value and on following day recheck pressure. If one or both of air springs have lost pressure, an air leak is present.

! *Leak must be repaired, and then retested until no leaks exist.*

Congratulations!

You have completed the installation.

Please proceed to the warranty information and operating guidelines & disclaimers

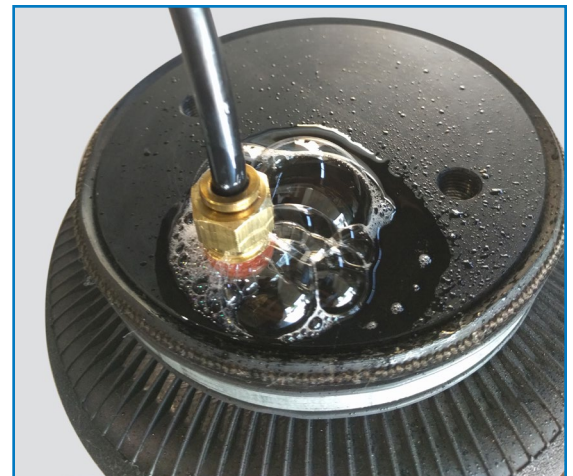

**Air Spring & NPT Air Fitting may differ between kits*

5

DISCLAIMER

Driving while distracted can result in loss of vehicle control that may lead to an accident, severe personal injury, or death.

The driver's primary responsibility is in the safe and legal operation of a vehicle, and use of any handheld devices, other equipment, or vehicle systems which take the driver's eyes, attention and focus away from the safe operation of a vehicle or which are not permissible by law should never be used during operation of the vehicle.

OPERATING YOUR VEHICLE WITH AIR SUSPENSION

Air springs have minimum and maximum recommended pressure requirements:

PART #	SPRING STYLE	SPRING TYPE	MIN PSI	MAX PSI
HP10189	In-Coil	STANDARD DUTY	5 PSI	70 PSI
HP10560		STANDARD DUTY		
HP10001	Sleeve Style	STANDARD DUTY	10 PSI	100 PSI
HP10173		STANDARD DUTY		
HP10199		STANDARD DUTY		
HP10083	Single Convoluted	HEAVY DUTY	5 PSI	100 PSI
HP10083J		HEAVY DUTY with JOUNCE BUMPER	0 PSI* / 5 PSI	100 PSI
HP10000	Double Convoluted	HEAVY DUTY	5 PSI	100 PSI
HP10000J		HEAVY DUTY with JOUNCE BUMPER	0 PSI* / 5 PSI	100 PSI
HP10068	Large Double Convoluted	HEAVY DUTY	5 PSI	100 PSI
HP10438	Double Convoluted	EXTREME DUTY	5 PSI	100 PSI
HP10438J		EXTREME DUTY with JOUNCE BUMPER	0 PSI* / 5 PSI	100 PSI

* Springs with a jounce bumper can be run at zero PSI when vehicle is unloaded only

For safe and proper operation, never operate the vehicle over the maximum listed PSI in the air springs. Staying under the pressure limit will ensure maximum air spring life. **Failure in doing so may result in damage to your vehicle and/or a void warranty.**

! *It is recommended to check the air pressure in your air springs daily for first couple of days to ensure a leak has not developed.*

Air springs are designed to maintain the vehicle's stock ride height with a load. Do not use the air springs as a means to lift vehicle with no load. This will result in a harsh ride.

SERVICING YOUR VEHICLE WITH AIR SUSPENSION

When lifting the vehicle with a floor jack or hoist on the frame, never allow the air spring to limit the travel of the axle. Try to always jack the vehicle on the axle. Suspending the axle with the air spring limiting the axle travel will damage the air spring and void the air spring warranty.

WARRANTY

See additional warranty included with this kit for details.

LEGAL

- Apple, the Apple logo, iPhone, and iPod touch are trademarks of Apple Inc., registered in the U.S. and other countries. App Store is a service mark of Apple Inc., registered in the U.S. and other countries.
- Google Play and the Google Play logo are trademarks of Google LLC
- Android is a trademark of Google LLC
- The Android robot is reproduced or modified from work created and shared by Google and used according to terms described in the Creative Commons 3.0 Attribution License.

FCC REGULATORY APPROVAL

Contains Transmitter Module FCC ID: 2ADHKWBZ451

This equipment has been tested and found to comply with the limits for a Class B digital device, pursuant to part 15 of the FCC Rules. These limits are designed to provide reasonable protection against harmful interference in a residential installation. This equipment generates, uses, and can radiate radio frequency energy, and if not installed and used in accordance with the instructions, may cause harmful interference to radio communications. However, there is no guarantee that interference will not occur in a particular installation. If this equipment does cause harmful interference to radio or television reception, which can be determined by turning the equipment off and on, the user is encouraged to try to correct the interference by one or more of the following measures:

- Reorient or relocate the receiving antenna.
- Increase the separation between the equipment and receiver.
- Connect the equipment into an outlet on a circuit different from that to which the receiver is connected. Consult the dealer or an experienced radio/TV technician for help.

IC REGULATORY APPROVAL

Contains transmitter module IC: 20266-WBZ451

This device complies with Industry Canada license-exempt RSS standard(s).

Operation is subject to the following two conditions:

- 1) This device may not cause interference, and
- 2) This device must accept any interference, including interference that may cause undesired operation of the device.

APPROBATION RÉGLEMENTAIRE IC

Contient le module émetteur IC: 20266-WBZ451

Le présent appareil est conforme aux CNR d'Industrie Canada applicables aux appareils radio exempts de licence.

L'exploitation est autorisée aux deux conditions suivantes:

- 1) l'appareil ne doit pas produire de brouillage, et
- 2) l'utilisateur de l'appareil doit accepter tout brouillage radioélectrique subi, même si le brouillage est susceptible d'en compromettre le fonctionnement.