

Installation Manual



10352 KIT

Ford Ranger (2WD/4WD)*

Use the most advanced air springs on the market to eliminate your vehicle's sag, sway and bottoming out. This heavy duty air suspension kit levels your truck's stance while providing added support for an overall smooth and safe ride.

* See application guide for proper fitment.



WARNING: This product can expose you to the chemical Hexavalent Chromate, which is known to the State of California to cause cancer and birth defects or other reproductive harm. *For more information go to www.P65Warnings.ca.gov*

IMPORTANT

This air suspension kit will not increase the GVWR (*Gross Vehicle Weight Rating*), as the GVWR is determined by the vehicle manufacturer. **Do not exceed the maximum capacity listed by the vehicle manufacturer.**

Safety Warning!

Serious personal injury or death may result from an air spring failure or accident due to improper installation or air spring pressure operation or maintenance. Please read and abide the instructions, safety recommendations and maintenance suggestions throughout this manual.

Safety Warning!

Inflating an unsecured air spring is dangerous. If it bursts, it could be hurled into the air with explosive force resulting in serious personal injury or death. Never inflate an air spring unless it is secured to the vehicle.

Safety Warning!

Removing and replacing air springs can be dangerous. This is only a job for a qualified service professional. Never perform air spring service procedures without proper training, tools, and equipment.

KIT CONTENTS

Reference the kit explosion diagram on the following page for part assembly.

KIT CONTENTS			QTY	PART #	REQUIRED TOOLS
A	Air Spring	2	HP10353	<ul style="list-style-type: none"> • Hoist or Floor Jack • Safety Stands • Safety Glasses • Torque Wrench • Standard Combination Wrenches • 7/32" Hex Allen Wrench • T40 Torx • 1-1/8" Wrench or Deep Socket • Ratchet • Metric & Standard Sockets • Hose Cutter (included) or Sharp Utility Knife • Pipe Thread Sealant • Spray Bottle with Dish Soap/Water • Air Compressor/Compressed Air Source (to test/fill air springs) 	
B	Upper Bracket	2	HP1581		
C	Lower Bracket (Passenger Side)	1	HP1583		
D	Lower Bracket (Driver Side)	1	HP1582		
E	Jam Nut, 3/4"-16	2	HP1076		
F	Hex Head Cap Screw, 1/2"-13 x 7/8"	2	HP1077		
G	Flat Washer, 1/2"	2	HP1368		
H	Hex Head Flange Bolt, M8 x 1.25 x 25	3	HP1430		
I	Flange Nut, M8	1	M5514		
J	Flat Washer, 1/2" x 2" OD	2	HP1010		
K	Carriage Bolt, 3/8"-16 x 1.25"	2	HP1149		
L	Flange Nut, 3/8"-16	2	HP1338		
M	Spacer, 1/4" (not shown)	1	C3858		
N	Straight Brass Air Fitting 1/8" NPT	2	HP1098		
O	Tie Straps (not shown)	6	C11618-8		
P	Heat Shield (not shown)	1	HP0012		
Q	Worm Gear Ring Clamp (not shown)	2	HP1001		
R	Air Line w/ Schrader Valves (not shown)	1	HP1344		
S	Hose Cutter (not shown)	1	HP10208		

Please make sure all the items shown in this explosion diagram are provided in your kit before starting the installation.

PASSENGER SIDE ASSEMBLY SHOWN:

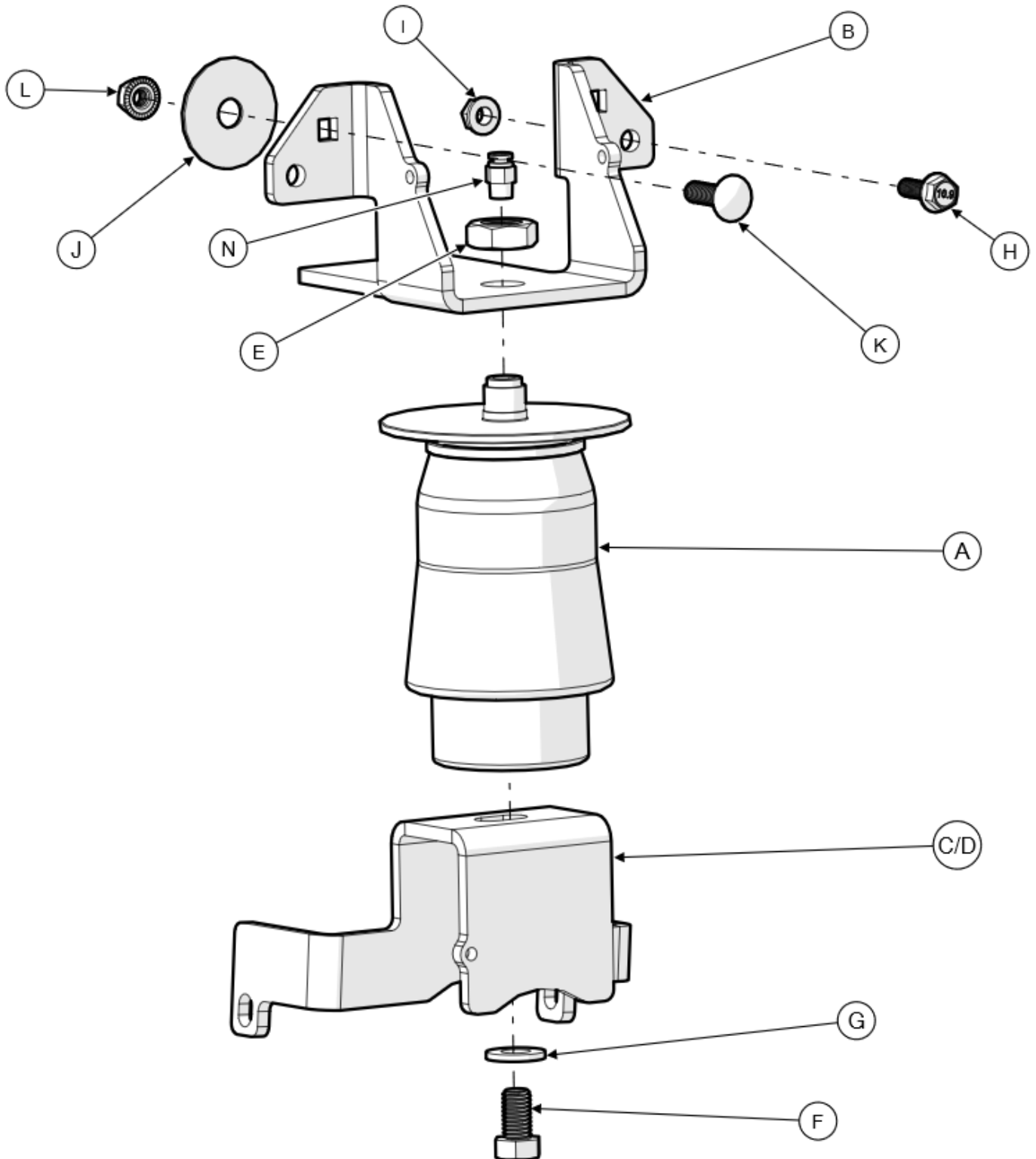

BEFORE STARTING THE INSTALLATION:

1. Ensure the application information is correct for the make, model and year of the vehicle you are installing the kit on.
2. Some vehicles are equipped with a rear wheel brake proportioning valve. Check with the manufacturer before installing the air spring kit, as it may affect braking performance.
3. It is recommended to use a good quality anti-seize on all fasteners. This will reduce the chance of corrosion on the fasteners and will help facilitate removal, if required at a later date.

PLEASE NOTE:

This kit contains push-to-connect fittings; using scissors or wire cutters to cut the nylon airline will distort the line and cause the connection to leak. THE AIRLINE MUST BE CUT OFF SQUARELY WITH THE NYLON HOSE CUTTER PROVIDED IN THIS KIT OR A SHARP UTILITY KNIFE.

1 MEASURE STOCK RIDE HEIGHT

Park the vehicle on a level surface.

Using a measuring tape, measure the distance between the center of the wheel hub and the bottom of the fender well (as shown in Figure 1) this will give you your ride height.

Note the ride height for all four corners.

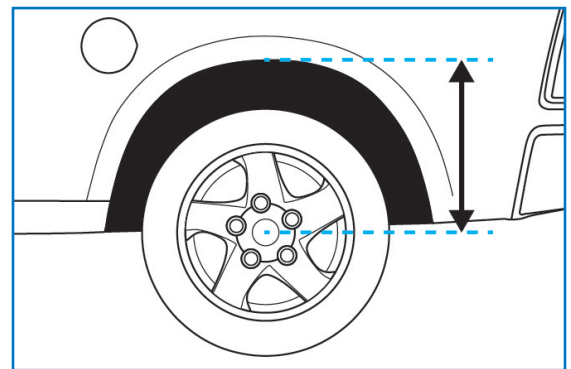

1

2 REMOVE REAR WHEELS

Place wheel chocks in front of and behind both front wheels.

Raise the rear of the truck high enough to remove both wheels and attain a comfortable working height.

Place two jack stands under rear axle (shown in Figure 2).

Lower the vehicle until the axle is supported by the jack stands.

Remove rear wheels.



2

3 REMOVE JOUNCE BUMPERS

Remove the bolt securing the jounce bumper to the frame rail using a 13 mm socket. A socket extension may be required to reach the bolt.

Remove the jounce bumpers and keep bolts for later reuse with upper brackets.

4 DETACH BRAKE HARDLINES

DRIVER SIDE ONLY:

Unclip the two brake hardlines (shown with arrows in Figure 4) attached to the inside of the frame rail above the jounce bumper mounting location. Allow these to hang loose for easier upper bracket installation.

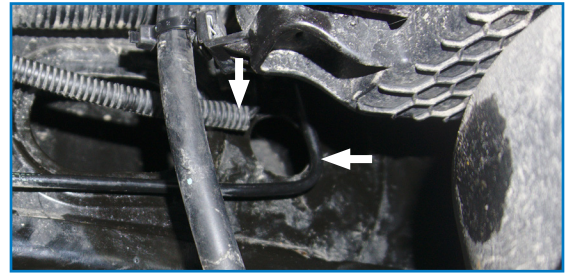

4

5 ASSEMBLE AIR SPRINGS

Assemble the air springs as shown in Figure 5. Place the upper bracket (B) on air spring (A) and secure using jam nut (E). Torque the jam nut to 25 ft-lbs (34 N-m) using a 1 1/8" socket.

Install the straight air fitting (N) into air spring finger tight, then tighten an additional 1 to 1.5 turns. It is recommended to use Teflon tape or some form of thread sealant to prevent air leaks.

Repeat for second air spring.

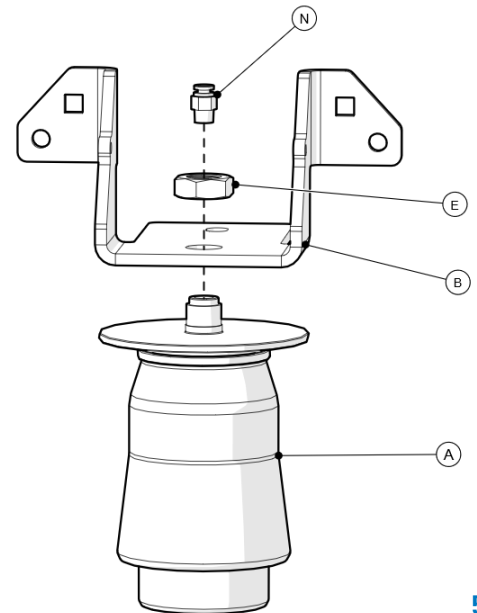

5

6 REMOVE ABS/BRAKE LINE BRACKET

On the rear side of the leaf spring perch, remove the bolt securing the ABS wire and brake line (shown in Figure 6) using a 13 mm socket.

Gently pull the bracket away from the spring perch and allow to hang freely.

Repeat for the opposite side.

Keep bolts for reuse for installing lower brackets.

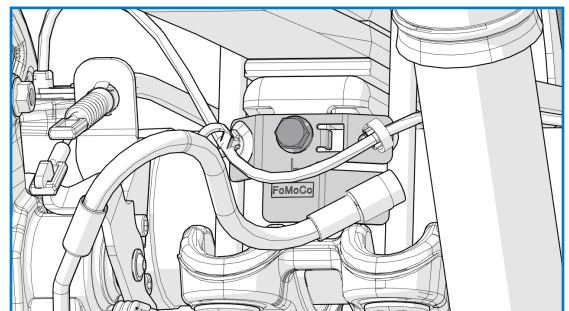

6

7 REMOVE E-BRAKE BRACKET FROM PERCH

On the front side of the leaf spring perch, remove the bolt securing the e-brake cable (shown in Figure 7) using a Torx T40 socket.

Gently pull the bracket away from the spring perch and allow to hang freely.

Repeat for the opposite side.

Keep bolts for reuse for installing lower brackets.

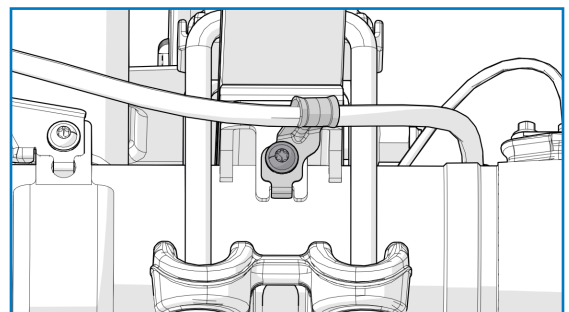

7

8 REMOVE E-BRAKE BRACKET FROM AXLE

On the passenger side of the axle, remove the bolt securing the e-brake cable to axle (shown in Figure 8) using a Torx T40 socket.

Allow the e-brake cable and bracket to hang loose.

Keep bolt for reuse.

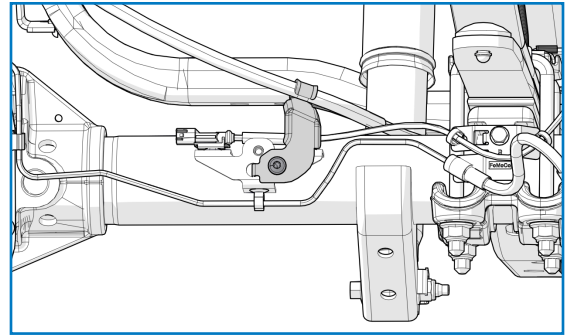

9 INSTALL LOWER BRACKETS

Install the driver side lower bracket (D) on the axle, inboard of the leaf spring (shown in Figure 9A). The bracket arms should wrap around the front and rear of the spring perch and sit flat against the perch.

The ABS wire/brake line bracket and e-brake bracket will mount outside the air spring bracket.

Secure ABS wire/brake line bracket and the lower bracket with the previously removed bolt from Step 6.

Torque to 21 ft.-lbs. (28 N-m).

Secure e-brake cable bracket and the lower bracket with the previously removed bolt from Step 7.

Torque to 17 ft.-lbs. (23 N-M).

Repeat on other side using passenger lower bracket (C).

Secure e-brake cable to the hole on the passenger lower bracket using supplied tie strap (O) (position shown in Figure 9B).

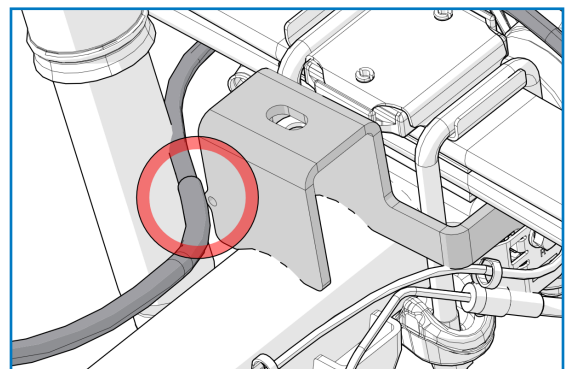
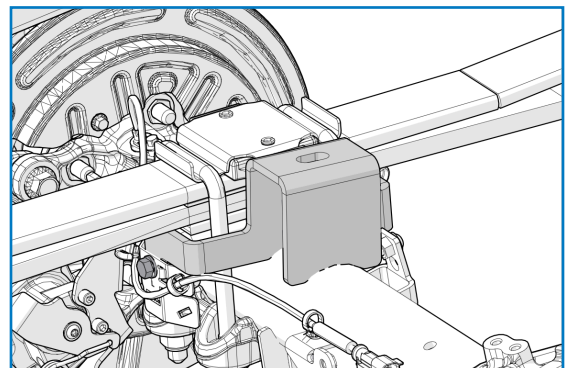

10 PREPARE DRIVER FRAME RAIL

On the driver side of the vehicle, locate the two bolts securing the brake hardline bracket above and slightly rearward of the jounce bumper mounting point (shown in Figure 10).

Remove two bolts using a 13 mm socket. Discard bolts.

Unclip the axle vent hose from the brake hardline bracket and allow to hang loose.

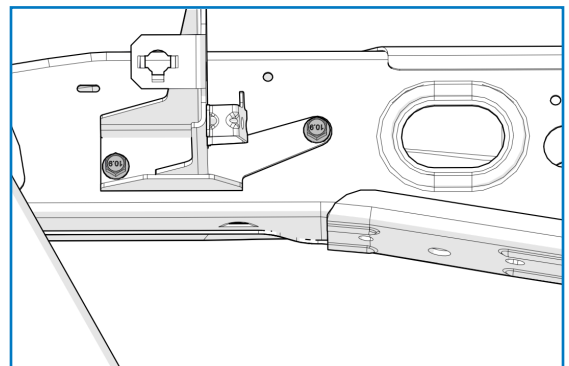

10

11 INSTALL DRIVER SIDE AIR SPRING ASSEMBLY

Lift the driver side air spring assembly into position against the inner frame.

Slide the upper bracket into place so that the forward mounting flange splits the two brake hardlines that were unclipped in Step 4. The flange will hook over the lower hardline and sit under the upper hardline (shown in Figure 11A).

Ensure the upper bracket sits flush against the underside and inside surfaces of the frame rail. Install the jounce bumper bolt from Step 3 to secure the bracket to the underside of the frame rail. Do not tighten yet.

Install the 3/8" carriage bolt (K) through square hole of forward mounting flange.

Reach through the oval opening in the frame rail and install the 2" OD flat washer (J) and 3/8" flange nut (L) and finger tighten onto carriage bolt.

The rearward mounting flange will sit between the frame rail and brake hardline bracket. Align the forward hole of the brake hardline bracket with the rearward round hole on the air spring bracket and secure using the M8 flange bolt (H).

Fully secure the brake hardline bracket using another M8 flange bolt (H) and a 1/4" spacer (M). Place the spacer between the bracket and frame rail.

Ensure the bracket sits flat as shown in Figure 11B.

Torque the jounce bumper bolt to 30 ft.-lbs. (40 N-m)

Torque the nut on carriage bolt to 30 ft.-lbs. (40 N-m)

Torque both M8 flange bolts to 21 ft.-lbs. (28 N-m)

Secure axle vent hose to upper bracket using tie strap (O).

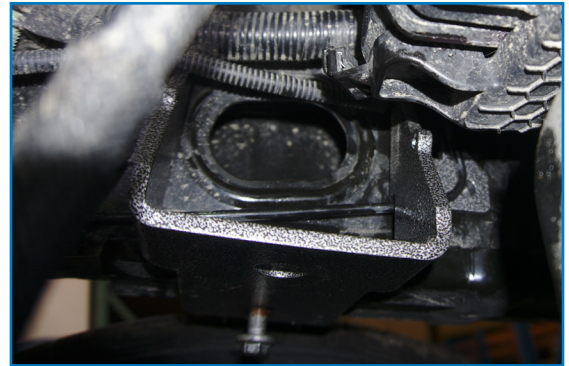

11A

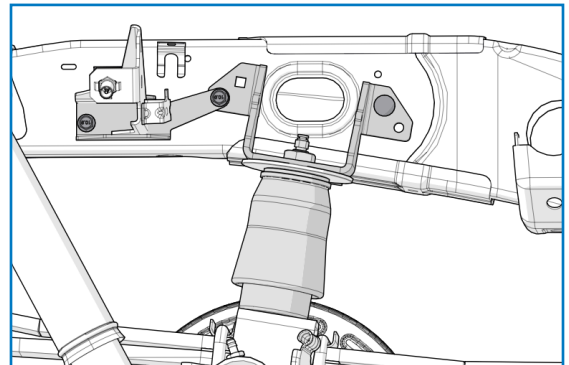

11B

12 INSTALL PASSENGER SIDE AIR SPRING ASSEMBLY

Slide the passenger side air spring assembly into place. Ensure the upper bracket sits flush against the underside and inside surfaces of frame rail (shown in Figure 12).

Install the reserved jounce bumper bolt from Step 3 to secure the upper bracket to underside of frame rail. Do not tighten yet.

Install the 3/8" carriage bolt (K) through the square hole of the forward mounting flange.

Reach through the oval opening in the frame rail and install the 2" OD flat washer (J) and 3/8" flange nut (L) finger tight onto the carriage bolt.

Install the M8 flange bolt (H) through the hole on the rearward flange.

Reach through the oval opening in the frame rail and install the M8 flange nut (I) on the flange bolt.

Torque jounce bumper bolt to 30 ft.-lbs. (40 N-m).

Torque nut on carriage bolt to 30 ft.-lbs. (40 N-m).

Torque nut on flange bolt to 21 ft.-lbs. (28 N-m).

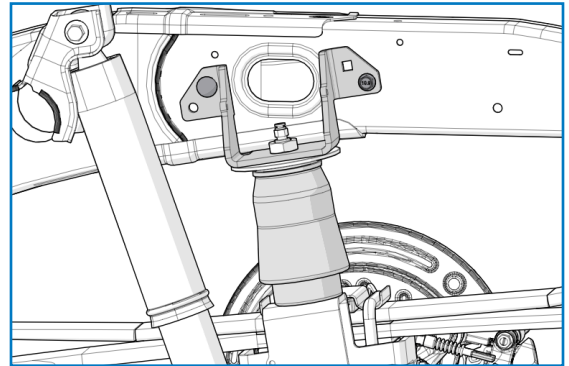

12

13 ATTACH AIR SPRING TO LOWER BRACKET

With the truck supported by the axle, so the suspension is at normal ride height position, secure bottom of the air spring to the lower bracket with a flat washer (G) and hex head cap screw (F) (shown in Figure 13). Adjust air spring such that top and bottom mounting points are aligned.

Torque to 25 ft.-lbs. (34 N-m).

Repeat for opposite side.

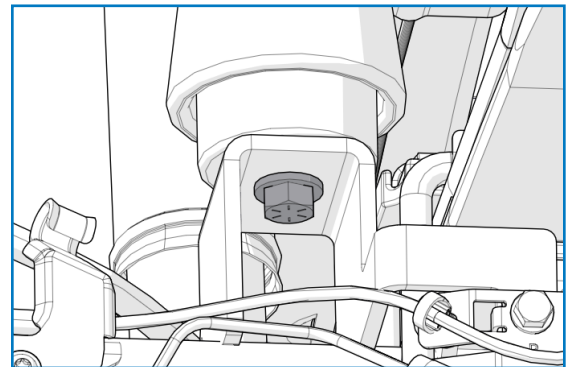

13

14 REATTACH E-BRAKE CABLE TO AXLE

Secure the e-brake cable bracket (removed in Step 6) to the axle with original removed bolt (shown in Figure 14). Adjust the position of bracket on the e-brake cable to maintain slack in cable.

Torque bolt to 17 ft.-lbs. (23 N-m).

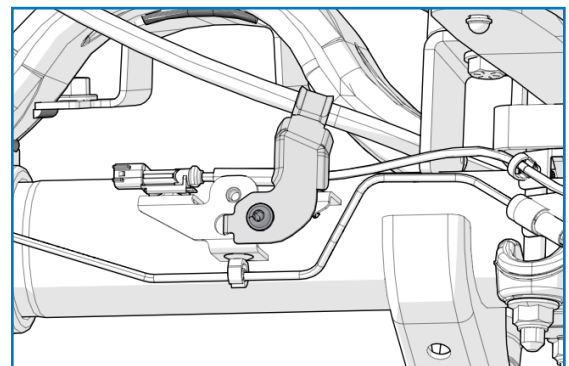

14

15 REATTACH BRAKE HARDLINES

On the driver side of frame rail, clip the two brake hardlines into original position, gently flexing the lines as needed to maintain clearance around upper bracket.

16 INSTALL HEAT SHIELD

Bend tabs on the heat shield (P) so the required $\frac{1}{2}$ " of dead space exists between the heat shield and exhaust when attached.

Attach the heat shield to the exhaust pipe on passenger side using two ring clamps (Q) (shown in Figure 16). Each hose clamp holds a tab against exhaust pipe.

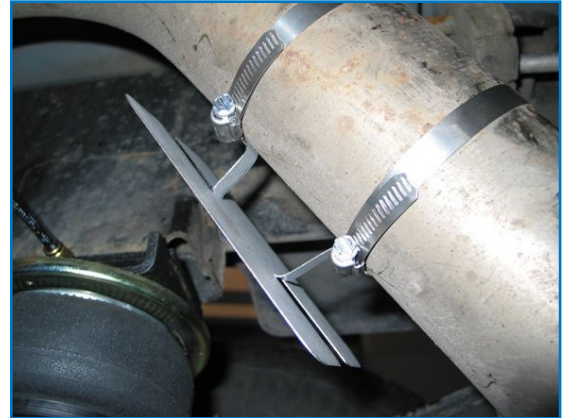

16

17 INSTALL AIR LINE

PLEASE NOTE: This kit contains push-to-connect fittings; using scissors or wire cutters to cut the nylon airline will distort the line and cause the connection to leak. THE AIRLINE MUST BE CUT OFF SQUARELY WITH THE NYLON HOSE CUTTER PROVIDED IN THIS KIT OR A SHARP UTILITY KNIFE

Provided in air spring kit are two fill valves. The most common place to install is in place of license plate fasteners. Alternatively, two $\frac{5}{16}$ " holes can be drilled in a convenient location.

Cut air line assembly (R) into two equal lengths with hose cutter (S).

Install one air line, route the nylon air line to an air spring fitting and cut the hose. Moisten the end of the air line prior to inserting it into the fitting and push it in until it stops. Repeat with the other fill valve.

Secure airlines using the tie-straps, away from moving items and heat sources.

Place a $\frac{5}{16}$ " nut on the air valve. Leave enough of the inflation valve in front of the nut to extend through the hole, install a flat washer, and $\frac{5}{16}$ " nut and cap (reference Figure 17 for assembly). There should be enough valve exposed after installation—approximately $\frac{1}{2}$ "—to easily apply a pressure gauge or an air chuck.

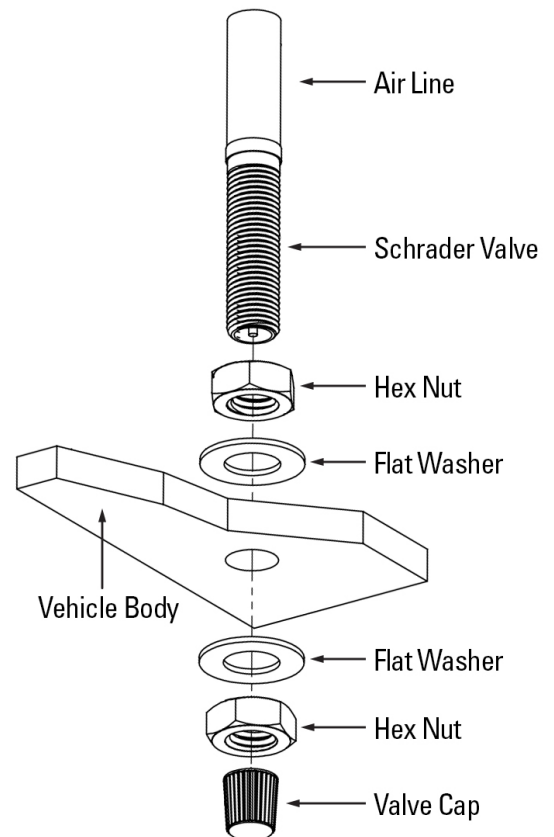

17

If an in-cab inflation kit is being installed, follow the instructions provided with that kit now.

18 CHECK SYSTEM FOR LEAKS

Inflate both air springs to 90 psi and then use a mixture of dish soap and water on all air line connections to detect any air leaks. Large, expanding bubbles indicate a leak (as shown in Figure 18). Repair as necessary and retest.

Inflate air springs to a predetermined value and on following day recheck pressure. If one or both of air springs have lost pressure, an air leak is present. Leak must be repaired, and then retested until no leaks exist.



18

19 AFTER COMPLETING THE INSTALLATION

PLEASE REMEMBER:

Install wheels and torque fasteners to manufacturer's specifications.

Re-torque all fasteners after first 500 miles of driving.

For safe and proper operation, never operate the vehicle under minimum of 10 psi or over maximum of 100 psi in air springs. Staying within pressure limit will ensure maximum air spring life. Failure in doing so may result in a void warranty (see **Note** below).

NOTE: Do not exceed maximum vehicle payload. Failure to do so may result in failure of the air suspension kit and/or damage to your vehicle.

Thank you again, and congratulations on the installation of the air suspension kit.

OPTIONAL ACCESSORIES

Optional dual needle air gauges are available to monitor pressure in each spring from vehicle cab, as well as a full line of air compressors, air tanks, and solenoids built to work with and control your air spring system.

OPERATING YOUR VEHICLE WITH AIR SUSPENSION

Air springs have minimum and maximum pressure requirements. Never operate your vehicle with less than 10 psi in air spring and never inflate air springs over 100 psi. Damage to air springs will result.

Check air pressure in air springs daily for first couple of days to ensure a leak has not developed. Air springs are designed to maintain the vehicles stock ride height with a load. Do not use the air springs as a means to lift vehicle with no load. This will result in a harsh ride.

SERVICING YOUR VEHICLE WITH AIR SUSPENSION

When lifting the vehicle with a floor jack or hoist on the frame, never allow the air spring to limit the travel of the axle. Try to always jack the vehicle on the axle. Suspending the axle with the air spring limiting the axle travel will damage the air spring and void the air spring warranty.

WARRANTY

To be eligible for warranty, the owner must submit their warranty card or register online within 30 days of the purchase date.

NOTE: The owner's warranty will be void if air springs are run with less than the minimum of 10 psi.

.....