

# Installation Manual

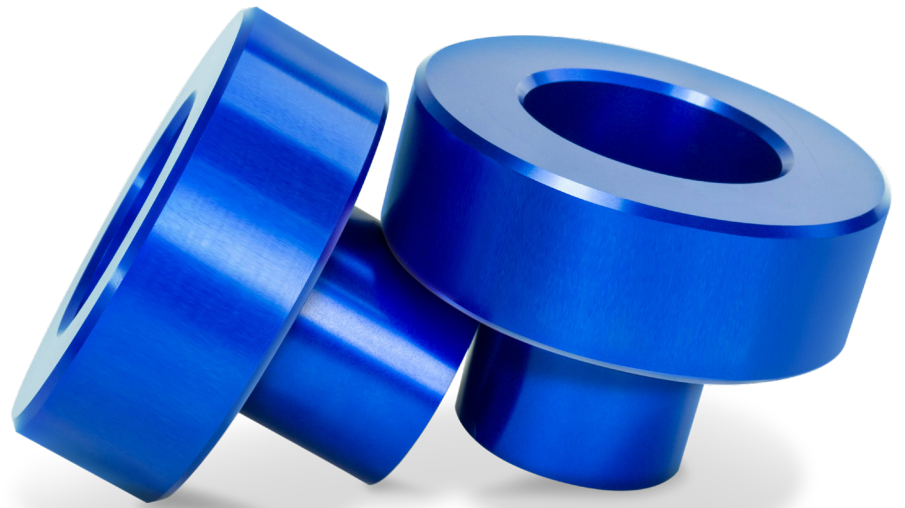

## 10294 KIT

**2.5" Leveling Kit** Ford F-250 / F-350 Super Duty (4WD)\*

*Levels the stance of your vehicle by raising the front end a fixed amount, increasing both the ground and wheel well clearance for the installation of larger wheels.*

**Thank you and congratulations on the purchase of a leveling kit. Please read the entire manual prior to starting the installation to ensure you can complete it once started.**

**KIT LAYOUT**



**KIT CONTENTS**

*Please make sure all the items shown in the above kit layout are provided in your kit before starting the installation.*

KIT CONTENTS			QTY	PART #	REQUIRED TOOLS	
<b>A</b>	Coil Spring Spacer	2	HP1468	<ul style="list-style-type: none"> <li>• Hoist or Floor Jack</li> <li>• Safety Stands</li> <li>• Safety Glasses</li> <li>• Torque Wrench</li> <li>• Standard Combination Wrenches</li> <li>• 7/32" Hex Allen Wrench</li> <li>• 1-1/8" Wrench or Deep Socket</li> <li>• Metric &amp; Standard</li> <li>• Sockets Ratchet</li> </ul>		
<b>B</b>	Shock Extension	2	HP1469			
<b>C</b>	Sway Bar Drop Bracket (Driver Side)	1	HP1504			
<b>D</b>	Sway Bar Drop Bracket (Passenger Side)	1	HP1505			
<b>E</b>	Brake Line Drop Bracket (Driver Side)	1	HP1472			
<b>F</b>	Brake Line Drop Bracket (Passenger Side)	1	HP1473			
<b>G</b>	M8 x 1.25 x 16 mm Hex Head Cap Screw	2	HP1146			
<b>H</b>	M14 x 2 x 90 mm Hex Head Cap Screw	2	HP1465			
<b>I</b>	M8 Flat Washer	2	C10473			
<b>J</b>	M14 Flat Washer	4	HP1466			
<b>K</b>	M8 x 1.25 Nyloc Nut	2	C11377			
<b>L</b>	M10 x 1.25 Flange Nut	4	HP1475			
<b>M</b>	M14 x 2 Nylon Lock Nut	2	HP1467			

Please make sure all the items shown in this explosion diagram are provided in your kit before starting the installation.

**KIT ASSEMBLY SHOWN:**

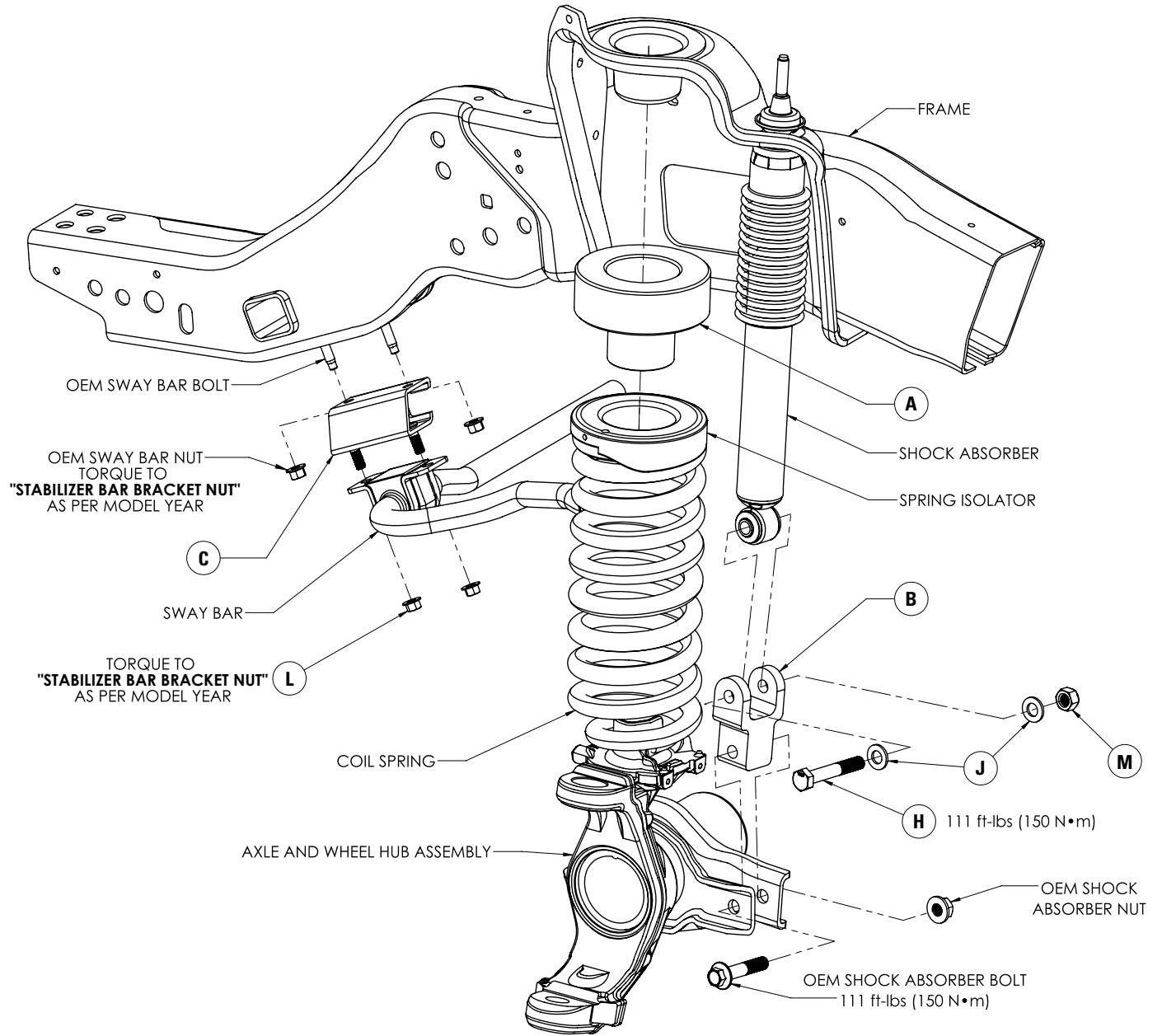

OEM TORQUE SPECIFICATIONS		
MODEL YEAR	2011-2016	2017-2021
SHOCK ABSORBER UPPER NUT	46 ft-lbs (63 N•m)	59 ft-lbs (80 N•m)
SHOCK ABSORBER LOWER BOLT	111 ft-lbs (150 N•m)	
STABILIZER BAR END LINK NUT	52 ft-lbs (70 N•m)	59 ft-lbs (80 N•m)
STABILIZER BAR BRACKET NUT	35 ft-lbs (48 N•m)	41 ft-lbs (55 N•m)
RADIUS ARM TO FRAME NUT	222 ft-lbs (300 N•m)	
TRACK BAR TO FRAME BOLT	406 ft-lbs (550 N•m)	

**BRAKE LINE RELOCATION ASSEMBLY SHOWN:**

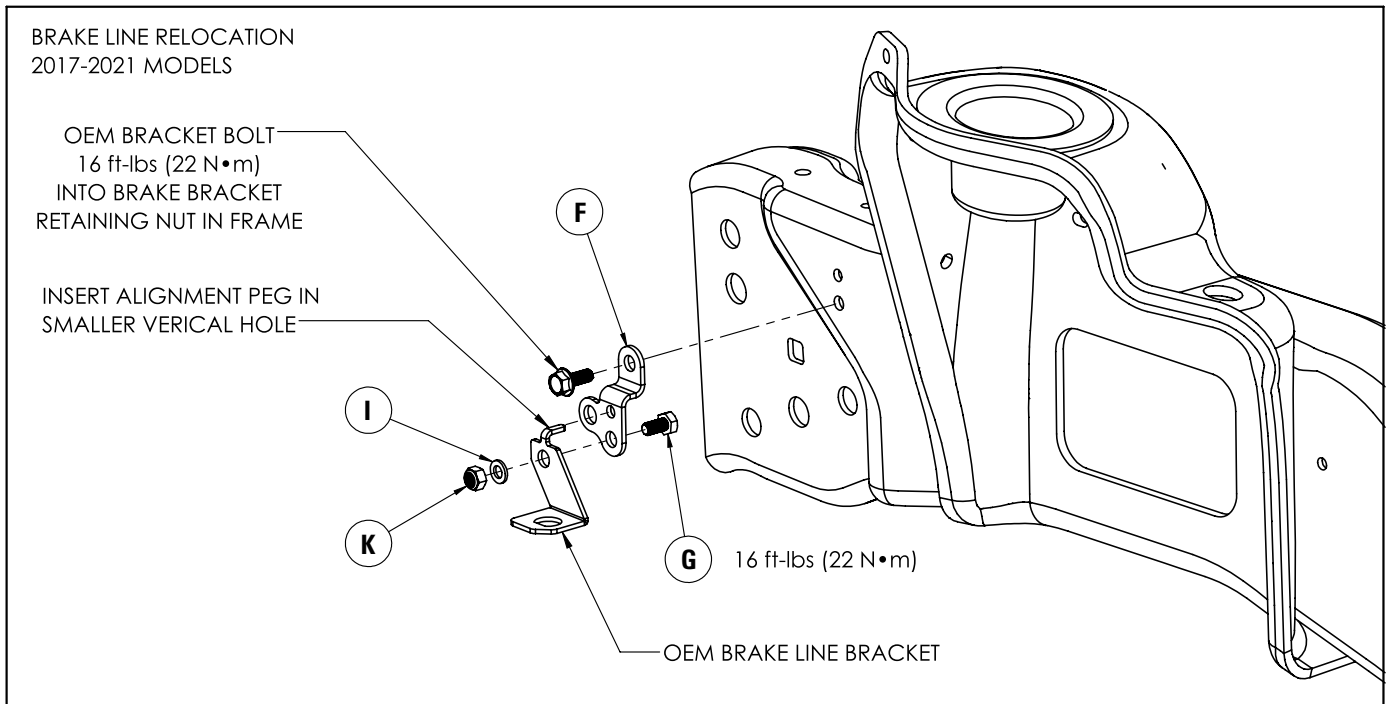
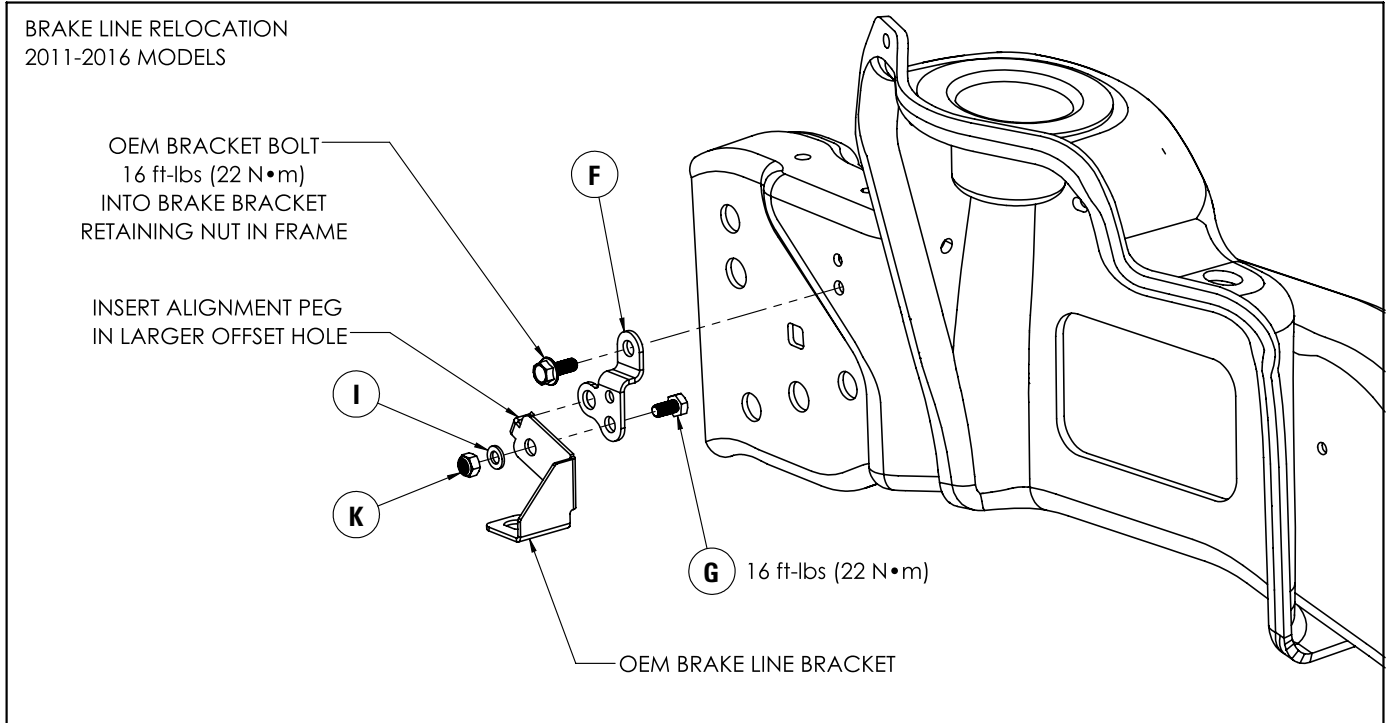

## BEFORE STARTING THE INSTALLATION:

### Safety Warning!

Altering the suspension system of your vehicle may cause it to handle differently than it did from the factory. Larger wheel and tire combinations may increase the leverage on the suspension and steering components. This changes the way your vehicles handles and responds to abrupt maneuvers. Operate your vehicle at reduced speeds in all conditions to prevent loss of control. Failure to do so may result in serious injury. It is not recommend to combine the use of suspension lifts, body lifts, or other lifting methods.

### Installation Warning!

Use caution when disassembling and reassembling the vehicle. The proceeding instructions are guidelines only, the installer is responsible for ensuring that the vehicle is safe for use after performing the installation. It is recommended to use the factory service manual for the model/year of the vehicle when disassembling and assembling factory related components.

Suspension components that use rubber or urethane bushings should be tightened with the vehicle at normal ride height. This will prevent premature wear or failure of the bushing. Prevent the suspension components from overextension by supporting them with a jack.

**PLEASE NOTE:** Due to the suspension geometry and vehicle tolerances, the amount of lift is a base figure. **Spacer thickness does not equate to the amount of lift due to the suspension geometry.** For example: a 1" thick spacer may provide a 2" lift. Always measure the vehicle ride height at all 4 corners before and after installation to ensure the results are as expected.

## WHEEL ALIGNMENT AND HEADLIGHT ADJUSTMENT

It is necessary to have a proper and professional wheel alignment performed by a certified alignment technician to align the vehicle to factory specifications. After the installation is complete, check to ensure that the vehicle's headlights are aimed properly. If not, a headlight alignment is required.

### 1 MEASURE STOCK RIDE HEIGHT

Park the vehicle on a level surface.

Using a measuring tape, measure the distance between the center of the wheel hub and the bottom of the fender well (as shown in Figure 1) this will give you your ride height.

Note the ride height for all four corners.

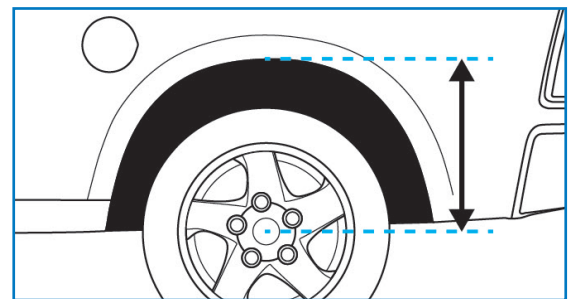

1

### 2 REMOVE FRONT WHEELS

Place wheel chocks in front of and behind both rear wheels.

Raise front of the truck high enough to remove both wheels and attain a comfortable working height.

Place two jack stands under the vehicles frame and lower vehicle until the frame is supported by the jack stands.

Remove front wheels (21 mm).



2

### 3 DISCONNECT THE TRACK BAR

Disconnect the track bar from the track bar mount that is connected to the frame. (Refer to Figure 3).

### 4 INSTALL THE BRAKE LINE DROP BRACKET

Remove the factory OE brake line support bracket from both the driver and passenger side.

Use the supplied fasteners to install the brake line drop brackets (shown in Figures 4A & 4B, as well as the BRAKE LINE RELOCATION ASSEMBLY diagrams shown on Page 4 of this manual)

**NOTE: Perform a steering sweep and inspect the front brake lines for adequate slack. Failure to perform this check may result in performance failure.**

### 5 DISCONNECT THE SWAY BAR

Disconnect the sway bar from the frame on both the driver and passenger side.

Install the provided sway bar drop brackets to the frame using the OE fasteners.

Torque the hardware to the manufacturer's specifications.

Raise the sway bar and attach it to the drop bracket using the M10 nuts that are provided.

Torque the M10 nuts to the OEM torque specs (found on Page 3).

### 6 DISCONNECT THE FRONT LOWER SHOCK BOLTS

Disconnect the lower shock bolts on the driver and passenger side. (Refer to Figure 6 on the following page).

**NOTE: It may be necessary to raise or lower the floor jack under the axle slightly (this relieves the pressure being applied by the shock on the bolt) making the removal of the lower shock bolts easier.**

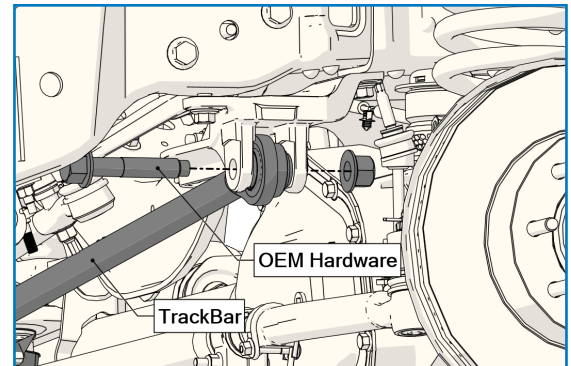

3

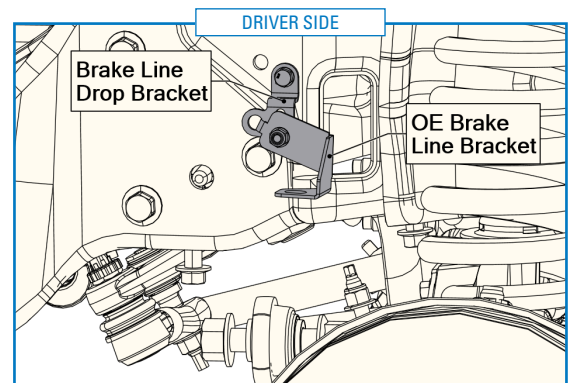

4A

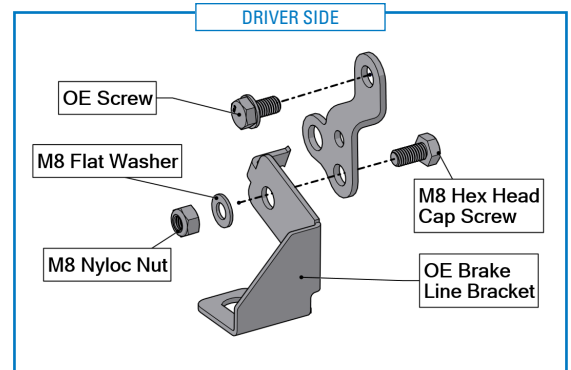

4B

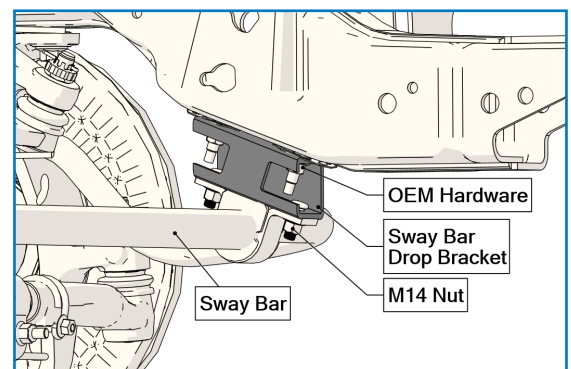

5

## 7 REMOVE THE COIL SPRING

Lower the front axle until there is enough clearance to safely remove the coil spring, and coil pad from the vehicle.

**NOTE:** You may need to disconnect the sway bar end links to allow the axle to drop further.

Repeat this step for both the Driver and Passenger side.

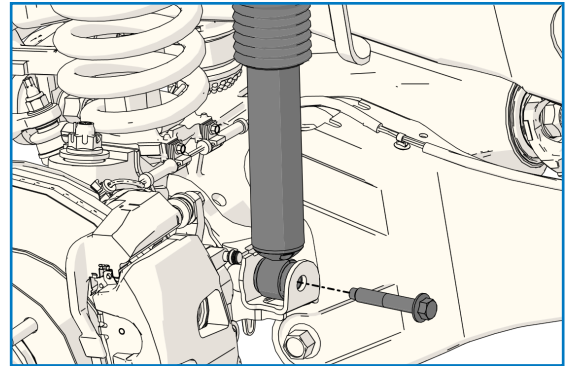

6

## 8 INSTALL THE COIL SPRING SPACER

Install the coil spring spacer, coil pad, and the coil spring back into the truck.

Slowly raise the axle until the bottom of the spring and the spring seat on the axle are nearly contacting each other.

Rotate the spring in order to clock the spring into the proper position.

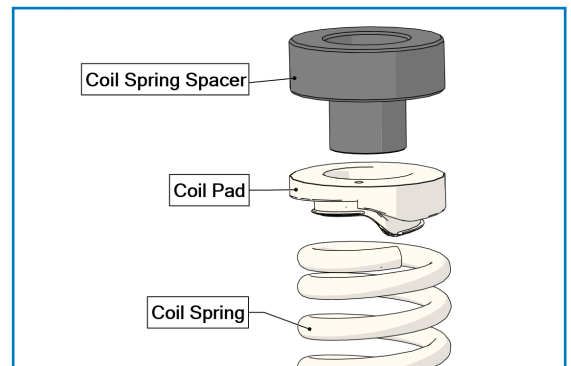

7

## 9 REINSTALL THE SHOCK

Install the provided shock extension bracket onto the factory OE mounting bracket and use the factory OE fasteners to attach the new bracket. (Refer to Figure 9).

Torque the fasteners to the manufacturer's specification.

Raise the axle such that the hole in the shock extension lines up with the hole located at the bottom of the shock absorber.

Install the provided M14 hardware and torque to the manufacturer's specifications (found on Page 3).

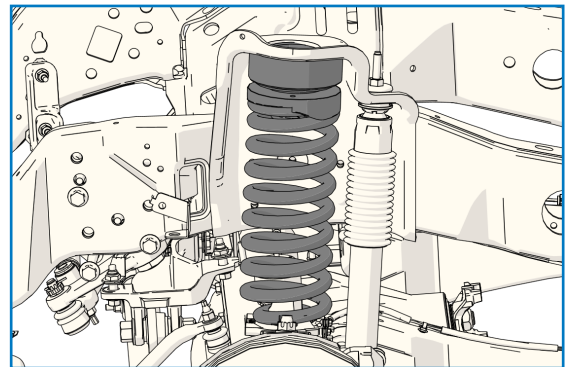

8

## 10 REINSTALL THE TRACK BAR

Reconnect the track bar to the frame track mount using the OE hardware (see Figure 3 on the previous page for reference).

Torque the hardware to the manufacturer's specifications (found on Page 3).

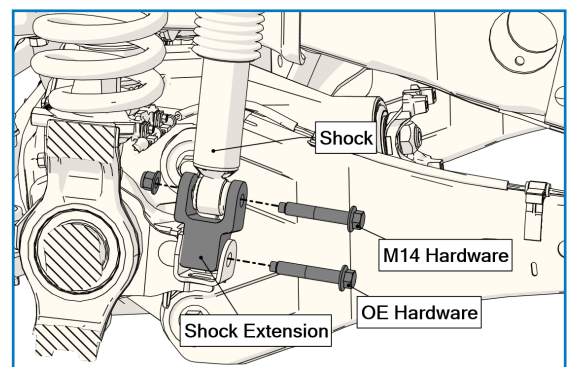

9

## 11 REINSTALL THE WHEELS

Install the wheels and torque them to factory specification.

Raise the vehicle in order to remove the jack stands from under the frame and then carefully lower the vehicle back to the ground.

Using a measuring tape, measure the distance between the center of the wheel hub and the bottom of the fender well for all four corners.

Note the distance between the wheel hub and the fender well, this is your new ride height. Ensure the results are as expected.

***Congratulations!***  
***You have completed the installation***

.....

## POST INSTALLATION WARNING

After the kit installation is complete and the vehicle is on the ground at its normal ride height, roll the vehicle backward and forward to settle the suspension. Tighten all components containing rubber bushings to the specified torque values. Verify adequate tire, wheel, brake line and ABS wire clearance by turning the front wheels completely to the left and then to the right. Ensure brake/ABS lines are not stretched when the suspension is at full droop. Test and inspect steering, brake and suspension components. Vehicle damage may result if the post installation checks are not performed.

## VEHICLE HANDLING WARNING

Larger wheel and tire combinations may increase the leverage on the suspension and steering components. Increasing the height of your vehicle increases the likelihood of rollover or loss of control during abrupt maneuvers, especially at high speeds. Operate your vehicle at reduced speeds in all conditions to prevent loss of control. Failure to do so may result in serious injury.

## WHEEL ALIGNMENT & HEADLIGHT ADJUSTMENT

After the kit installation is complete, a professional wheel alignment must be performed by a certified alignment technician to re-align the vehicle to within factory specifications. Additionally, ensure that the vehicles headlights are aimed properly. If not, a headlight alignment is required as well. If not properly aligned it can cause increased tire and suspension component wear.

## VEHICLE RE-TORQUE & SAFETY INSPECTION

After the kit installation and adjustments have been completed and within 50 miles of driving, perform a check over of all applicable fasteners and hardware to ensure they are adequately tightened to the specifications given (or as noted in the vehicle's factory service manual).

## WARRANTY

To be eligible for warranty, the owner must submit their warranty card or register online within 30 days of the purchase date.