



# SILVER SPORT *Transmissions*



## HYDRAULIC KIT INSTRUCTIONS FOR GM - MUNCIE

**BEFORE INSTALLING TRANSMISSION IN CAR, YOU MUST**  
**CHECK THE HYDRAULIC BEARING CUSHION**  
**MEASUREMENT!!!**

**SEE PAGE 7 OF INSTALLATION MANUAL FOR INSTRUCTIONS ON  
MEASURING HYDRAULIC BEARING CUSHION. RECORD THIS  
MEASUREMENT FOR FUTURE REFERENCE.**

**DAMAGE WILL OCCUR IF THIS  
MEASUREMENT IS INCORRECT!!!**

*The material herein is the intellectual property of Silver Sport Transmissions ("SST") and is to be used by SST customers or their authorized installers for the sole purpose of installing SST-supplied transmissions and related parts. Under no circumstances shall the manual or any portion thereof be copied, duplicated, distributed or incorporated in any written or printed document without the express written approval of Silver Sport Transmissions.*

**SYSTEM DESCRIPTION:**

This system uses a firewall-mounted hydraulic master cylinder with remote reservoir and a combination slave cylinder/release bearing assembly. This combination bearing is called a concentric slave cylinder (CSC) and **it is designed to be in constant contact with the pressure plate fingers**. The CSC is compressed by the pressure plate fingers when at rest. When the clutch pedal is depressed, the master cylinder forces fluid into the CSC, causing it to expand and depress the pressure plate fingers, thereby releasing the clutch.

This system is designed to use **DOT 4** brake fluid. **DO NOT use DOT 5 brake fluid!** The seals in this system are not compatible with DOT 5 fluid, and will be ruined on contact with it.

For higher temperature applications or if heat-related issues arise, the use of ATE Super Blue DOT 4 fluid is recommended.

This system is engineered for use with a diaphragm-style pressure plate and is **NOT compatible with most three-finger style pressure plates.**

It is recommended that you remove the over-center spring (if equipped) from the clutch pedal when using a diaphragm-style pressure plate.

**KIT CONTENTS**

Please confirm that all parts have been received. The parts contained in your Master Cylinder kit are car-specific, and are listed on your Master Cylinder packing list. The parts contained in your Slave Cylinder kit are:

- Front bearing retainer with anti-rotation pin
- Combination slave cylinder/release bearing
- Braided steel hose with bleeder
- 3/8"-16 socket head cap screws (4)



**DISASSEMBLY**

Remove original clutch linkages, transmission and bellhousing components:

- Fork push rod, clutch pedal push rod assembly
- Z-bar retaining clip, Z-bar, ball stud and bracket assembly
- Fork boot
- Drive shaft
- Shifter Handle and Shift Mechanism (if 3 or 4 speed equipped)
- Transmission and bellhousing
- Throw-out bearing, clutch fork and fork pivot

### **MASTER CYLINDER MOUNTING**

1. From under the hood, locate the factory clutch pushrod hole. On automatic cars, this may be a hole with a rubber grommet or a small sheet metal cover with two screws. On some cars, it is part of the steering column opening in the firewall. If there is a cover over an existing hole, remove the cover. Some vehicles may not have a factory hole in the firewall, but there should be a spot that is contoured for a hole. That spot is usually located below and slightly to the left (driver's side) of the brake master cylinder or brake booster mount, near the steering column.

2. If no clutch rod hole exists in your firewall, measure the diameter of the pushrod hole in the clutch master cylinder mounting block (the side that is against the firewall). Cut a hole of that size in the factory spot on the firewall. Some cars may require elongating the hole due to the angle of the master cylinder.



3. From the engine compartment, insert the master cylinder pushrod through the firewall and center the master cylinder pushrod in the hole, keeping the mount block against the firewall. Confirm that the pushrod points toward and reaches the clutch pedal attachment point (see "PEDAL ATTACHMENT" section). **NOTE: 1968 - 1982 Corvettes require that the master cylinder be rotated so that the ports on the top are pointed slightly towards the driver's side in order for the pushrod to be aligned with the clutch pedal.** Carefully mark the firewall for each of the mounting bolt holes using a transfer punch, center punch or marker.
4. Drill a 3/8" diameter hole through the firewall for each marked location. Remove burrs.
5. Assemble mount block gasket to mount block, then set the master cylinder and mount block assembly to the firewall. See diagram on following page. Assemble 5/16"-18 bolts through the assembly and firewall. On some applications it will be necessary to insert one or more bolts (usually the bottom bolt) from the passenger compartment side of the firewall.
6. From passenger compartment, assemble backing plate, lock washer and nuts. Align master cylinder, then tighten bolts to 25 ft-lb.
7. Assemble the 90° end of the braided steel line to master cylinder port closest to firewall.
8. Assemble barb fitting to master cylinder at port located furthest from firewall. Use caution not to over tighten and break fittings.

**CAMARO/FIREBIRD 67-69  
BEFORE INSTALLATION**

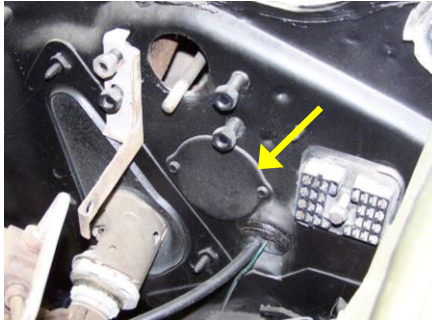

**68-72 CHEVELLE  
BEFORE INSTALLATION**

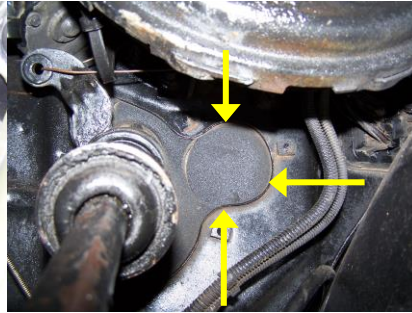

**C1 VETTE**



**CAMARO/FIREBIRD 67-69**



**64-67CHEVELLE**



**C2 VETTE**



**Typical Master Cylinder Assembly:**

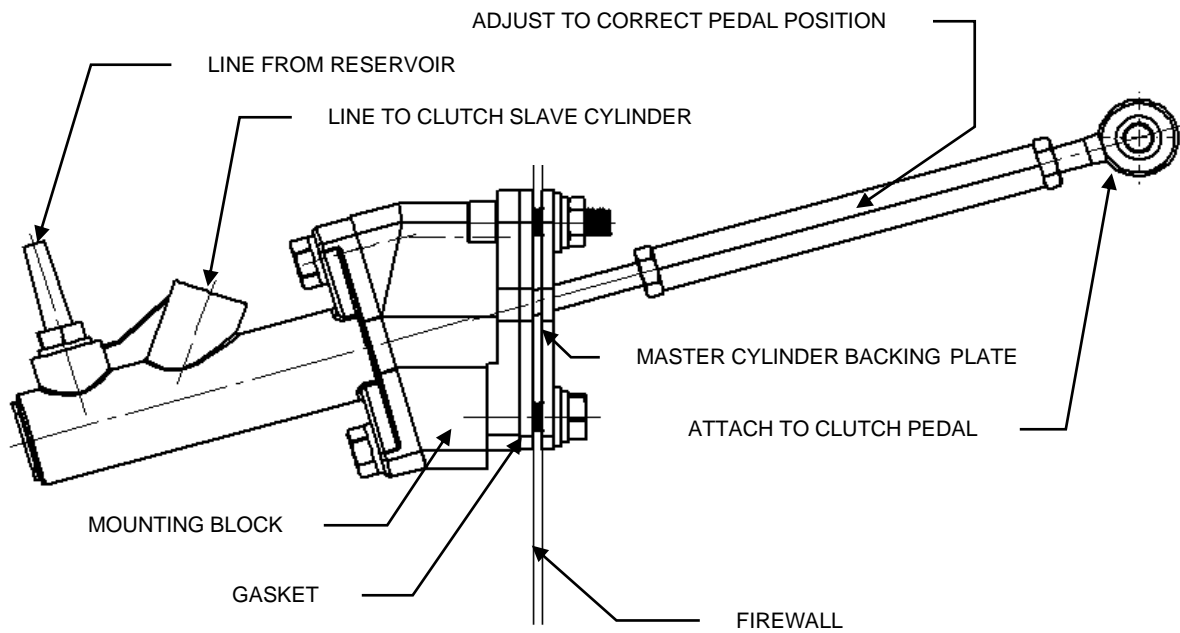

## FLUID RESERVOIR MOUNTING

1. Remove the studs or nuts on the left hand (driver) side of the brake master cylinder.
2. Place reservoir bracket over the two holes or studs in the brake master cylinder, replace the original studs or nuts and tighten completely. Alternatively, the reservoir may be attached directly to firewall.
3. Assemble reservoir to the bracket using hardware supplied (part # CAA-PACK A).



## SLAVE CYLINDER MOUNTING

**NOTE: This procedure involves removal of the transmission's front bearing retainer and replacement with SST's custom bearing retainer. Please take care during the procedure to keep your work environment as clean as possible.**

1. Remove four (4) bolts holding the front bearing retainer to the transmission (FIG. A).
2. Remove the front bearing retainer by tapping lightly with a mallet to break it free.
3. Remove gasket and thoroughly clean mating surface (FIG. B).
4. Apply small bead of RTV Silicone Gasket Maker (PERMATEX Ultra Grey or equivalent) to mounting face of bearing retainer as shown (FIG. C). Be sure not to apply excessive sealer near the oil slot area to prevent blocking the front bearing oil feed hole in the face of the transmission case.
5. Place the bearing retainer on the transmission ensuring that the oil slot located at 7 o'clock lines up with the oil galley hole in case and that the dowel pin is positioned at the top (FIG. E).
6. Attach the bearing retainer to the transmission using (4) socket head cap screws. Apply Teflon sealant to threads of bolts (FIG. D). Torque the bolts to 20-25 ft-lb in an "X" pattern.
7. Slide Concentric Slave Cylinder (CSC) over input shaft and dowel pin (FIG. F).
8. Make sure the CSC is positioned so that the hydraulic inlet points towards the fork opening in your bellhousing. You will only use the 1 ear located at the top for the dowel pin to pass through, the second and third ears are not used.
9. Continue with the remainder of your hydraulic clutch kit installation.

**FIG. A  
REMOVE RETAINER/BOLTS**



**FIG. B  
REMOVE OLD GASKET**

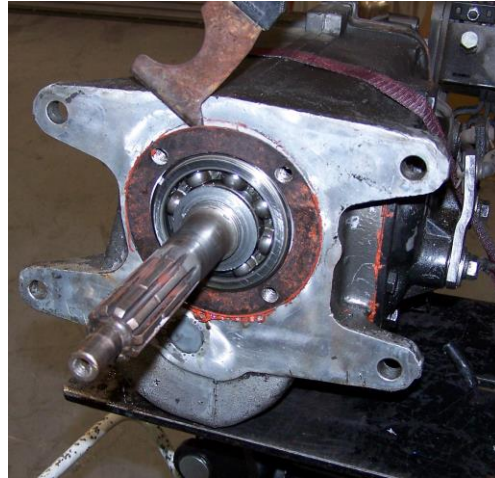

**FIG. C  
APPLY RTV GASKET MAKER**



**FIG. D  
APPLY THREAD SEALANT**



**FIG. E  
INSTALL BEARING RETAINER**

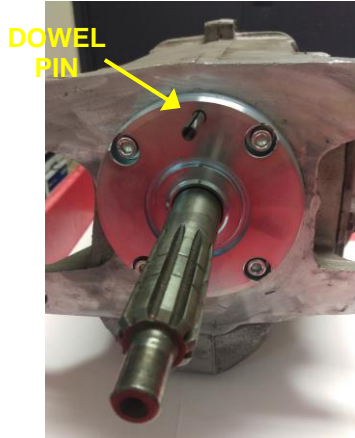

**FIG. F  
INSTALL CSC**



## HYDRAULIC BEARING CUSHION CHECK

The CSC is designed to be compressed  $\frac{1}{2}$ " or more by the pressure plate fingers at rest. The CSC needs a minimum of  $\frac{1}{8}$ " extra room to allow for clutch disc wear and expansion from heat. Clutch slippage will result if the CSC bottoms out and is partially depressing the pressure plate fingers at rest. The CSC cushion measurement procedure below tells you how far the CSC is away from being completely bottomed out. The acceptable range for CSC cushion is between  $\frac{1}{8}$ " (0.125") and  $\frac{3}{8}$ " (0.375").

1. With the correct clutch pressure plate and clutch disc mounted and torqued to the flywheel, install the bellhousing to the engine.
2. Use a straight edge and a steel rule to measure from the transmission mounting face of the bellhousing to the surface of the clutch fingers that contacts the release bearing. Record this depth measurement ( X ) (FIG. K).

**FIG. K**

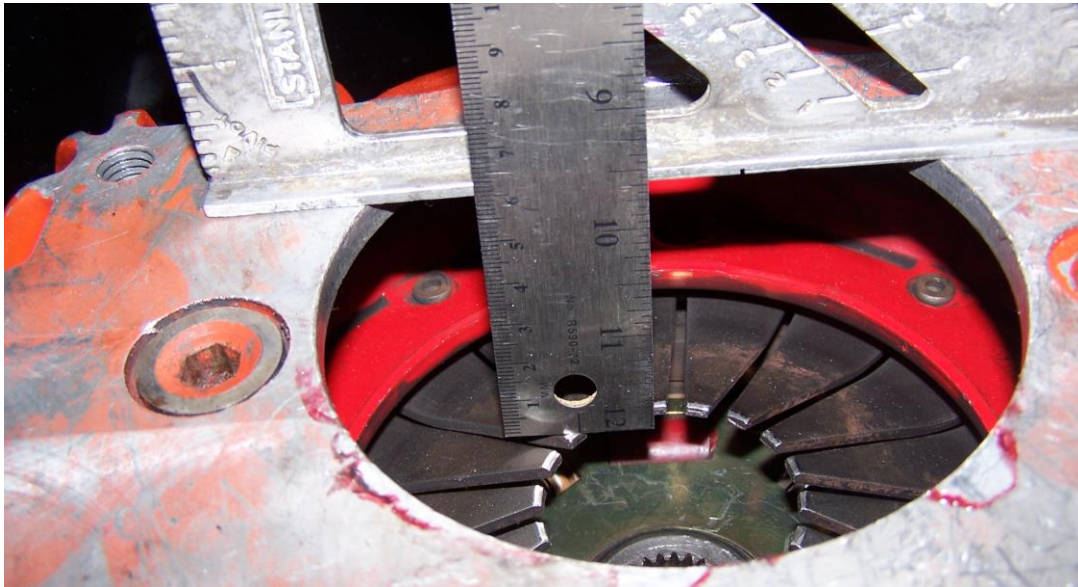

3. Your depth measurement above ( X ) minus **2.52"** (about 2 -17/32") gives you the cushion measurement:

$$( X ) - 2.52" = \text{CUSHION}$$

4. The resulting cushion dimension should be **between  $\frac{1}{8}$ " (0.125") and  $\frac{3}{8}$ " (0.375")**, with  $\frac{1}{4}$ " (0.250") **being the ideal** nominal cushion. If your cushion is not within this  $\frac{1}{8}$ "- $\frac{3}{8}$ " range, first confirm the accuracy of the measurements. If still not within this range call Silver Sport Transmissions to obtain spacers to achieve the correct cushion.

## TRANSMISSION MOUNTING

1. Remove bellhousing from engine and install bellhousing to transmission. Tighten bolts only lightly at this time.
2. Install black rubber fork hole boot onto the end of the braided steel line that has the bleeder screw on it. Insert that end of the line through the bellhousing fork hole and attach braided steel line to CSC. Test-fit the line following the angle of the threads, not the angle of the machined face (see photos on the next page).

**NOTE: Be very careful not to cross-thread the fitting.**

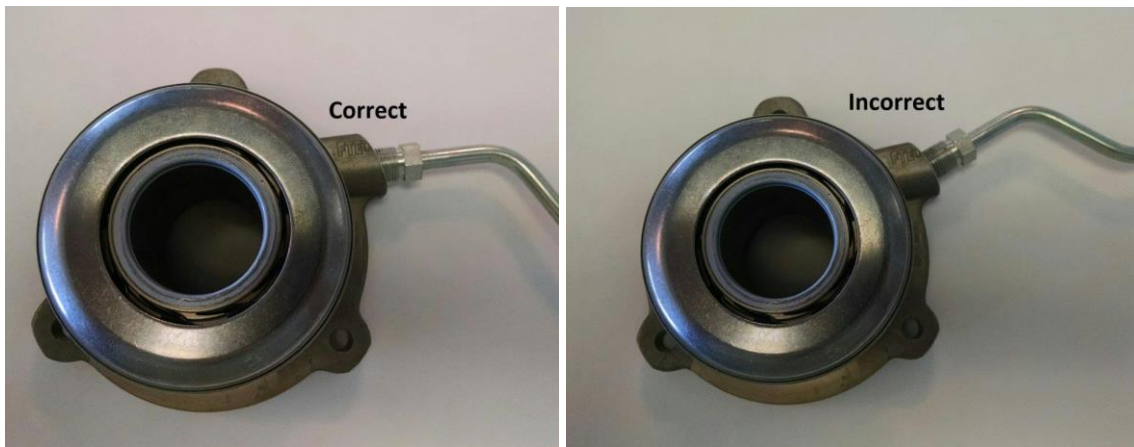

**The line is designed for the bleeder screw to point downwards** in order to reduce the chance of brake fluid getting on painted surfaces on your car during the bleeding process.

3. Verify the braided steel line is towards the back of the bellhousing and away from rotating components.
4. The transmission, bellhousing and hydraulic throw-out bearing are installed as a unit to the engine.

#### **HYDRAULIC LOW PRESSURE HOSE MOUNTING**

1. Run the rubber supply hose from the bottom of the reservoir nipple to the barb fitting in the clutch master cylinder, and determine the exact length for the supply hose. The hose should be neither tight nor excessively loose, and should clear all moving steering gear and exhaust components. Take care to prevent foreign debris from entering hose.
2. Cut the line to desired length, ensure that no foreign matter is in the hose, then loosely assemble hose clamps.
3. Install hose to the master cylinder, then to the reservoir. When installing hose to the reservoir, hold the top of the reservoir to prevent overloading and damaging the mounting ears.

#### **HYDRAULIC HIGH PRESSURE HOSE MOUNTING**

1. After bolting the transmission/bellhousing unit to the engine, attach the remaining end of the braided steel line to the clutch master cylinder and tighten. Use caution not to over tighten and break the fitting.
2. Final tighten all transmission mounting bolts (4 pcs).
3. Inspect the supply line inside bellhousing and confirm the hoses have ample clearance to the rotating clutch plate. It is extremely important that the hydraulic clutch hose **DOES NOT** come into contact with the clutch plate, as serious damage could result.

**NOTE: DOT 4 BRAKE FLUID REQUIRED. SHIELD HYDRAULIC LINES FROM HEAT, ESPECIALLY NEAR EXHAUST HEADERS.**



## PEDAL ATTACHMENT

**NOTE:** If you are changing from a three (3) finger style pressure plate to a diaphragm style pressure plate you should also remove the clutch pedal over center spring, if equipped with one. Failure to remove the over center spring could result in the spring holding the clutch pedal down during normal operation. The over center spring will also tend to hold the pedal down while performing the bleeding operation with both the three finger and diaphragm style clutches during bleeding until the system is bled enough to return the pedal. An over center spring is not recommended for use with a diaphragm-style clutch, and the hydraulic system is not compatible with some three-finger style clutches.

### Shoulder Bolt Attachment (uses part # CAA-PACK F)

1. If there are two possible attachment holes in your clutch pedal arm, use the hole that best lines up with the pushrod coming out of the master cylinder. **NOTE: 1955 - 1957 Chevrolet master cylinder pushrod attaches to the rod lever on the passenger side of the steering column.**
2. Adjust heim rod end position to achieve proper pedal height with master cylinder clutch push rod extended to its upper internal stop. If the master cylinder is not at its internal stop position when the pedal is at rest, the master cylinder vent/fill port could be blocked, preventing successful bleeding of the system. Make sure the pushrod travels in and out of the master cylinder in a nearly straight line and does not contact the firewall, mount block, or backing plate at any point during its travel. When desired pedal height is achieved, tighten locknut on pushrod.
3. Assemble shoulder bolt through heim joint of master cylinder pushrod.
4. Assemble spacer, if needed, to shoulder bolt, in between heim joint and clutch pedal, then assemble to clutch pedal. Attach with washer and lock nut. Tighten to 20 ft-lb. **NOTE: You may have to loosen the brake light switch bracket to insert the bolt. In some applications, a small adjustment of the switch position may be required to clear the bolt head.**

**DO NOT pump the pedal until fluid is added to the reservoir.  
USE ONLY DOT 4 BRAKE FLUID.**

### Clevis-type Attachment

1. Adjust rod end position to achieve pedal in home position with clutch push rod fully extended. When desired position is achieved, tighten locknut on pushrod.
2. Install rod end, flat washer, then spring clip retainer or cotter pin.

**SHOULDER BOLT TYPE**



**CLEVIS TYPE**



## HYDRAULIC FLUID FILL & BLEED

You will need two people to bleed this clutch system. Use caution to prevent brake fluid from contacting paint, as damage will likely occur. If your vehicle has an over-center spring installed, it will tend to hold the clutch pedal to the floor until the system is bled enough to return the pedal itself. Remove reservoir cap and baffle from the reservoir.

1. Fill the reservoir full with **DOT 4 brake fluid**. During the next steps check regularly to make sure that the reservoir does not run out of fluid. If this happens you will have to start the process over.
2. Open the bleeder screw to allow air to escape from the system. Give the fluid a few minutes to make its way down to the bleeder screw. Allow fluid to drip from the bleeder screw into a suitable container. Don't forget to keep fluid in the reservoir!
3. When the drip becomes a steady stream, close the bleeder screw. Refill the fluid reservoir. Open the bleeder screw slightly and have your helper depress the pedal. Close the bleeder as soon as the pedal reaches the floor. Then have your helper release the pedal. The pedal may need to be manually pulled up from the floor during these steps. Repeat this process several times, refilling the reservoir every 3 strokes or so.
4. When the bleeder stops spitting air, close and tighten the bleeder screw. Pump the pedal several times to check for proper feel. Repeat the process if the pedal is not firm throughout its travel, or if it seems that the clutch is not releasing fully. Make sure that the master cylinder pushrod is traveling its full stroke of 1.4" and that the master cylinder is fully extended when the clutch pedal returns to its home position.
5. If bleeding proves difficult for one reason or another, a manual vacuum bleeder can be used to draw a vacuum on the reservoir and thereby the entire system and pull trapped air into the reservoir. With the rubber baffle removed from the reservoir and the cap installed, apply vacuum to the vent hole in the center of the cap. You may try stroking the pedal while vacuum is being applied. Repeat until the system is bled. It may be necessary to prime the master cylinder by removing the high pressure hose at the master cylinder and block the fitting outlet to draw fluid into the cylinder when stroking the pedal. When the cylinder is primed, reattach the pressure line and continue the bleeding procedure. Take care not to spill brake fluid on any painted surfaces.
6. Upon successful bleeding, fluid level will need to be lowered to approximately 1/3 full. Excess fluid may be removed from the reservoir by siphoning with a hand-held vacuum pump or with a spoon or medicine cup. Reinstall baffle and cap.
7. Inspect for leaks, and replace the bellhousing inspection cover.
8. Check fluid level and add if necessary after the first test drive or after vehicle sits overnight. **NOTE: It may be necessary to bleed the clutch again after minimal use, as operation may dislodge some trapped air.**

## INSPECTION AND TESTING

**USE EXTREME CAUTION WHEN TESTING YOUR CLUTCH RELEASE SYSTEM.  
DO NOT TEST IN HIGH TRAFFIC OR PUBLIC AREAS.**

### ENGINE-OFF TEST

Parking brake set, test the release and engagement of the clutch mechanism. Check for the following:

1. Clutch pedal completely up at its home position when released, and that the master cylinder pushrod is fully extended when the pedal is all the way up.
2. Clutch pedal does not hit brake lamp bracket or other bracket.
3. Low resistance for initial travel when depressing clutch pedal. Clutch resistance increasing at 1/3 of full stroke and remaining approximately constant through full travel to the floor.
4. Clutch pedal travel to floor without over-travel of clutch plate. Over-travel is characterized by a sudden hard pedal. This should not be a problem if the "Hydraulic Bearing Clearance Check" was accurately made.

**NOTE: The hydraulic slave cylinder has approximately 7/8 inch total stroke, minus the free play that was measured earlier. Most clutches release within 1/2 inch travel.**

5. Smooth system operation with no abnormal noises.

### ENGINE-ON TEST:

Hold brake, place transmission in neutral, start engine. Achieve idle of 1000 rpm or less.

1. Depress clutch pedal.
2. Ease shifter into gear. **CAUTION:** If transmission gears start to grind, pull back to neutral and stop engine. Repeat bleeding process.
3. Slowly release clutch pedal while maintaining brake pedal pressure. Confirm engine is being loaded as clutch pedal is released.
4. Repeat test step 1-3 through all gears, including reverse.

**NOTE: Reverse is not synchronized, and grinding may occur. This can be eliminated through placing shifter in forward gear immediately before proceeding to reverse gear setting.**

## **CARE AND MAINTENANCE**

Your SST hydraulic clutch actuator system is designed to give you years of trouble-free service. In order to maximize the life of the system:

- Periodically check fluid level, hose clamps and hoses for damage.
- Flush the hydraulic fluid every 2 years with new, clean **DOT 4** brake fluid.

## **SYSTEM SPECIFICATIONS**

Master cylinder: Bore = 0.750"  
Stroke = 1.400"

CSC: Stroke = .910"

Fluid: **DOT 4** brake fluid required. **DO NOT USE DOT 5 FLUID.**

## **ACCESSORY ITEMS**

The following accessory items will enhance your installation:

- SST Cast Titanium-Aluminum Bellhousing. New casting features super high strength aircraft alloy, lightweight 15lbs, precision CNC machining for accurate alignment of transmission to crank bore, 168 tooth flywheel mounting. For both 4 & 5 speeds.
- Clutches/Flywheels – We carry a full range of clutches, and both billet steel and aluminum flywheels.
- SST Reproduction Pedal Assemblies – New precision made pedal conversion allow easy conversion from automatic, or quality replacement parts for restoration.
- SHIFTER HANDLES & MECHANISM – Full line of 4 & 5 speed shifter handles and shift balls.

### **CONTACT INFORMATION**

SILVER SPORT TRANSMISSIONS  
2250 STOCK CREEK BOULEVARD  
ROCKFORD, TENNESSEE 37853-3043

Phone: (865) 609-8187  
Toll Free: (888) 609-0094  
Fax: (865) 609-8287

[WWW.SHIFTSST.COM](http://WWW.SHIFTSST.COM)

*SILVER SPORT TRANSMISSIONS IS DEDICATED TO YOUR SATISFACTION AND ENJOYMENT OF THIS PRODUCT. PLEASE SEND US PICTURES OF YOUR CAR ALONG WITH A TESTIMONIAL OF HOW YOU RATE THIS PRODUCT. WE WILL BE POSTING MANY CUSTOMER FEEDBACK LETTERS AND PICTURES ON OUR WEBSITE AND BROCHURES.*

**ENJOY YOUR SILVER SPORT  
TRANSMISSION SYSTEM!**