



## 1.25 Performance Upper Arm Instructions

Dodge Ram 1500 4wd `09-18

### PARTS SUPPLIED

QTY	Description	ID
8	Polyurethane pivot bushings	1
4	7/8" od x 9/16" id x 1.92" sleeves	2
4	90 deg. zerk grease fittings (self-tapping)	3
2	9/16" tapered uniball spindle adaptors	6
2	9/16" upper domed uniball spacers	5
2	9/16-18 x 4" 12pt bolts	4
2	9/16" SAE grade 8 round washers	7
2	9/16-18 stover lock nuts	8
4	Grease packets	
4	Camburg 8.5" Stickers	

\*\* REFER TO EXPLODED CAD DRAWING ON \*\*  
 \*\* OTHER SIDE FOR PARTS REFERENCE NUMBERS \*\*

Thanks for purchasing a set of our Camburg 1.25 uniball performance upper a-arms for your vehicle. Please follow all instructions. If you are not installing these yourself have a qualified shop do so. These arms are designed for 1-3" of lift and to be used with stock OEM spindles. These are not designed for models with air ride suspension. Make sure to check the parts list to make sure you have every component prior to starting. Camburg Engineering has made every attempt to insure you receive the highest quality components in the most complete manner. This is a guide to help you through the process with recommended torque specs. It's your responsibility to ensure parts are being installed correctly using the correct tools and procedures.

### Tools & Supplies Required

Eye protection | Jack | Jack Stands | Deburring Tool  
 2-3 lb. mini sledge hammer | Rubber Mallet  
 18mm socket & wrench | 21mm socket | 9/16" 12pt socket  
 7/8" socket | 1/4" wrench | Torque wrench | Needle Nose Pliers  
 Small Flat Screwdriver | Brake cleaner | Anti-seize  
 Red Loctite | Zip ties

### 1.0 Setup

Park the vehicle on level ground and set the parking brake and chock both rear wheels. Jack up the front end from the chassis until the front tires are off the ground. Place jack stands under the front frame rails and set down. Make sure the vehicle is supported correctly and the front tires are still off the ground. Place the jack under the driver side lower arm and raise the tire 1/2", then remove the wheel while keeping jack under lower a-arm to support the suspension. Read these instructions start to finish before moving forward and review diagrams.

### 2.0 Removal

Disconnect the ABS wire from the backside of the OEM upper arm. Using a 21mm socket, loosen the nut on the upper ball-joint where it connects to the spindle but do not fully remove. With a mini sledge hammer strike the top of the spindle numerous times to release the ball-joint tapered stud. This can be a little difficult since it's a press fit, heating up the spindle to get it to expand will help if need be. Once the ball joint releases from the spindle, then remove the nut. This will allow you to position the upper arm and spindle out of the way. Make sure to position & support the spindle so that it doesn't pull on the brake line and it doesn't pull out the inner CV or strain the CV boots and axles. Use a 18mm socket & wrench to loosen and remove the OEM upper a-arm bolts. These will be re-used during installation, so keep track of their orientation and position. Remove the stock upper arm.

### 3.0 Pre-Installation

Using a 1/4" wrench install the self-tapping zerk fittings into the Camburg arms. Do not bottom out the fittings into the arms.

..... Position them pointing outward for grease gun access. Now press the polyurethane bushings into the arms. Using the supplied bushing grease, apply grease onto the OD of the inner pivot sleeves and press into the bushings. Wipe excess grease onto outer bushing face and apply additional grease if needed. See diagram for reference.

Using a countersink bit or deburring scraper tool, slightly chamfer the top-hole edge of the ball-joint taper in the spindle. This will allow the spacer to fully seat when tightened and eliminate possible stress risers. Then inspect and clean the tapered hole. See diagram for reference.

### 4.0 Installation

Install the driver side Camburg upper arm into the frame using the original hardware in the same orientation as it was removed. To insure you're installing the correct arm, the pivot gussets will be on top, the zerk fittings and uniball snap-ring below and the longer a-arm tube towards the front of the vehicle. Our arms are built with higher precision and tighter tolerances than the factory arms, so it will be a tighter fit into the frame. You may need to pry the outer tabs out very slightly to make it easier to install. When the stock arms are tightened from the factory it bends the tabs slightly in. With the bolts pushed all the way through, clean the threads with brake cleaner and apply a little red Loctite to the nut area. Use a 18mm wrench and 18mm socket and torque to 120 ft/lbs.

Prior to installing the tapered uniball adaptor spacer into the spindle, make sure the spindle taper is clean and free of debris. Apply anti-seize to the uniball spacers and insert the tapered lower uniball spacer into the uniball. Then install the upper spacer into the top of the uniball making sure both spacers are fully seated. If not, damage will occur in the following steps. Wipe off excess anti-seize and install the 9/16" 12pt bolt through the spacers and uniball and attach the upper arm to the spindle by swinging it down to the spindle with some finesse. You may need to jack up the lower arm and move the uniball joint. The tapered spacer should sit almost flush with the top of the spindle before tightening. Make sure the lower spacer did not pull out slightly from the uniball or damage will occur as the spacer can get caught on the bearing race and/or snap ring.

Due to the extreme and punishing nature of offroad use, Camburg Engineering products have no implied or expressed warranty. Camburg Engineering products and components are designed and manufactured for offroad use only. Installing most suspension products will raise the center of gravity of the vehicle and can increase the susceptibility to a rollover and alter the handling characteristics. Camburg Engineering products may void the vehicles warranty, check with your local dealer. The loss of use of the product, loss of time, inconvenience, removal, shipping costs, commercial loss or consequential damages are not covered. Camburg Engineering reserves the right to change the design, material or specifications of any product without assuming any obligation to modify any product previously manufactured and without prior notice. Every effort has been made to avoid printing errors and specifications. By installing and/or using these products you are accepting these stated conditions and accept all liability and responsibility.

.... Install the 9/16" washer and stover lock nut with a small amount of red Loctite onto clean threads. Using a 9/16" 12pt socket and 7/8" socket, torque to 120-125 ft/lbs. Do not over-tighten or use an impact gun. See diagram for reference.

Lastly, use a zip tie to attach the ABS wire to the upper arm or frame in a location and position that insures it won't be damaged.

**Repeat steps 1 through 4 to install passenger side arm**

### 5.0 Alignment

You will need to have your vehicle aligned by a qualified shop. Additional caster is built into the Camburg arms to correct alignment issues that are inherent with lifting the vehicle. Have your alignment shop increase/maxout positive caster, then set camber and toe to factory OEM specifications. Having an increase in caster helps with straight line stability and cornering precision for performance driving on and off-road.

### 6.0 Maintenance & Care

Uniballs are precision parts with tight tolerances which can lead to occasional noise when they become dirty. Occasionally wipe off the top and underside of the uniball with a clean rag to remove road grime and dirt. Cleaning and lubricating them with WD-40 or a PTFE dry film lube like "Tri-Flow" can minimize any noise from stiction. Do not use harsh chemicals or grease/oils that attract dirt to clean & lube as it will damage and wear the internal PTFE liner. Over time the pivot bushings will also need to be cleaned and lubricated. Use grease that's designed specifically for polyurethane bushings. Not using the correct grease can cause the bushings to squeak abnormally and wear faster. The best method to grease the bushings is to remove the arms from the vehicle, disassemble, clean and lubricate. When using a grease gun, do so slowly. Most grease guns operate at 1500+ psi. and can damage the bushings applying too much pressure too fast. Neglecting care and upkeep will wear parts out faster. We recommend greasing the poly bushings 1-2 times per year or every 6-10k miles depending on use.

Inspect and re-torque all hardware and components after 500 miles and whenever using the truck off-road.

### Notes

Recommended tire size: 285/70/17 (33")  
Recommended wheel size: 17 X 8-9"  
Recommended wheel backspacing = 4.75"  
Maximum wheel backspacing = 5.00"

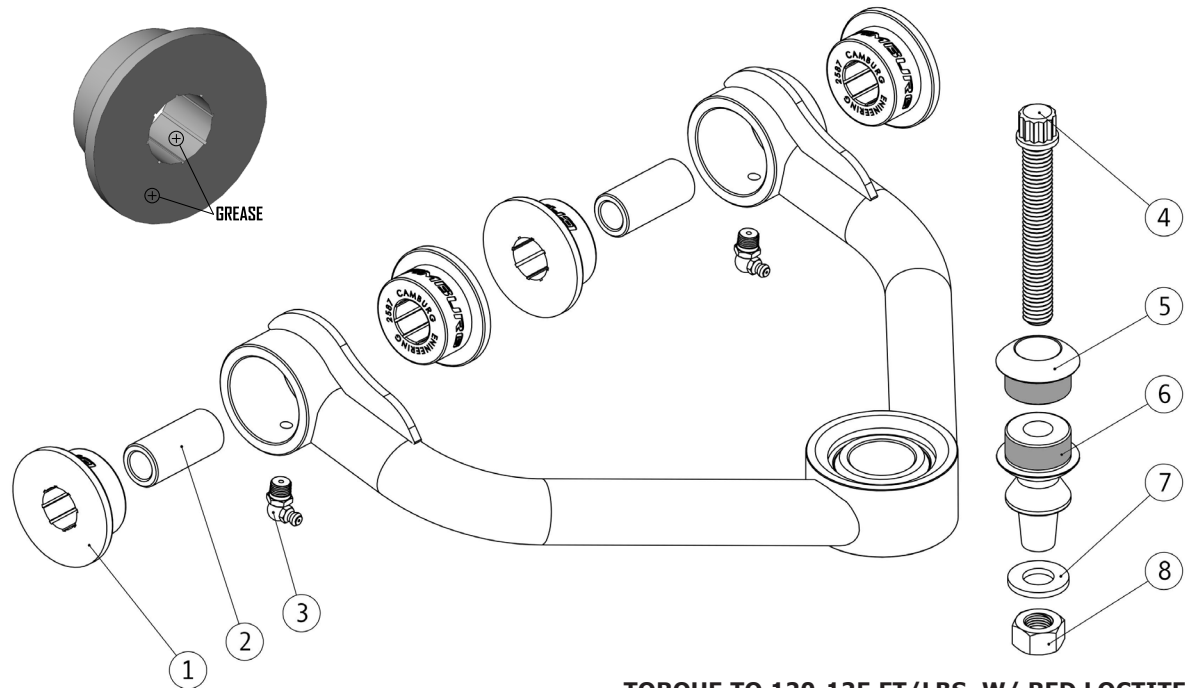

**TORQUE TO 120-125 FT/LBS. W/ RED LOCTITE**

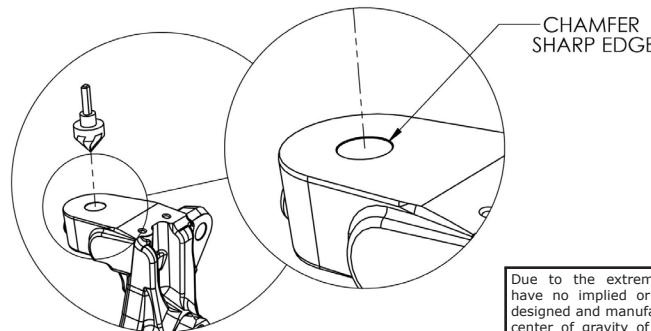

Due to the extreme and punishing nature of offroad use, Camburg Engineering products have no implied or expressed warranty. Camburg Engineering products and components are designed and manufactured for offroad use only. Installing most suspension products will raise the center of gravity of the vehicle and can increase the susceptibility to a rollover and alter the handling characteristics. Camburg Engineering products may void the vehicles warranty, check with your local dealer. The loss of use of the product, loss of time, inconvenience, removal, shipping costs, commercial loss or consequential damages are not covered. Camburg Engineering reserves the right to change the design, material or specifications of any product without assuming any obligation to modify any product previously manufactured and without prior notice. Every effort has been made to avoid printing errors and specifications. By installing and/or using these products you are accepting these stated conditions and accept all liability and responsibility.