



Thanks for purchasing our performance spindles for your Toyota Tundra/Sequoia. If you are not installing these yourself have a qualified shop do so. These spindles were designed to replace the OEM versions and work with parts associated with them. Check the parts list to make sure you have every component prior to installing. Camburg Engineering has made every attempt to insure you receive the highest quality components in the most complete manner. This is a guide to help you through the process with some recommended torque specs & notes. It's your responsibility to ensure parts are being installed correctly using the correct tools and procedures to the proper torque. For step-by-step instructions refer to a Toyota or Haynes service/repair manual.

**Important Notes:**

- On 2016+ models you will need to drill out the brake caliper bolt holes in our spindles to 9/16" as they use larger metric bolts. Verify OEM bolt size prior to drilling. Use the supplied M14 bolts to attach the brake calipers.
- On 2007-2015 models you will use the supplied M12 bolts to attach the brake calipers.
- The OEM front brake rotor dust shields will not be re-used.
- Use supplied zip ties for ABS sensor wire.
- Maximum Wheel Backspacing = 6.25"
- When running larger than stock tires we recommend wheels with 4.75"-6.00" of backspacing.
- Use RED loctite on all fasteners > 1/4" dia.
- Use BLUE loctite on all fasteners < 1/4" dia.
- On older or higher mileage 4wd vehicles we recommend replacing the inner hub seals.

**Recommended Torque Specs:**

- Ball-Joint Cradle M18 Bolts = 220 ft/lbs.
- Hub Unit Bolts = 73 ft/lbs.
- 4wd Axle Shaft Hub Nut = 249 ft/lbs.
- '07-15 Brake Caliper Bolts = 73 ft/lbs.
- '16-20 Brake Caliper Bolts = 133 ft/lbs.
- Outer Tie Rod Castle Nut = 51 ft/lbs.
- Ball-joint Upper Arm Castle Nut = 81 ft/lbs.
- Uniball Upper Arm Nut = 125 ft/lbs.

ID	PART NBR	DESCRIPTION	QTY
		DRIVER SIDE SPINDLE	1
		PASSENGER SIDE SPINDLE	1
	330028	STOCK LENGTH STAINLESS BRAIDED FRONT BRAKE LINE KIT	1
	950172	M12 X 1.25 X 30 FLANGE HEAD HEX BOLT (ZINC)	4
	950173	M14 X 1.50 X 30 FLANGE HEAD HEX BOLT (YELLOW ZINC)	4
	950093	14" TY-28MX ZIP TIE (BLACK)	4
	030017	CAMBURG 8.5" STICKERS	4

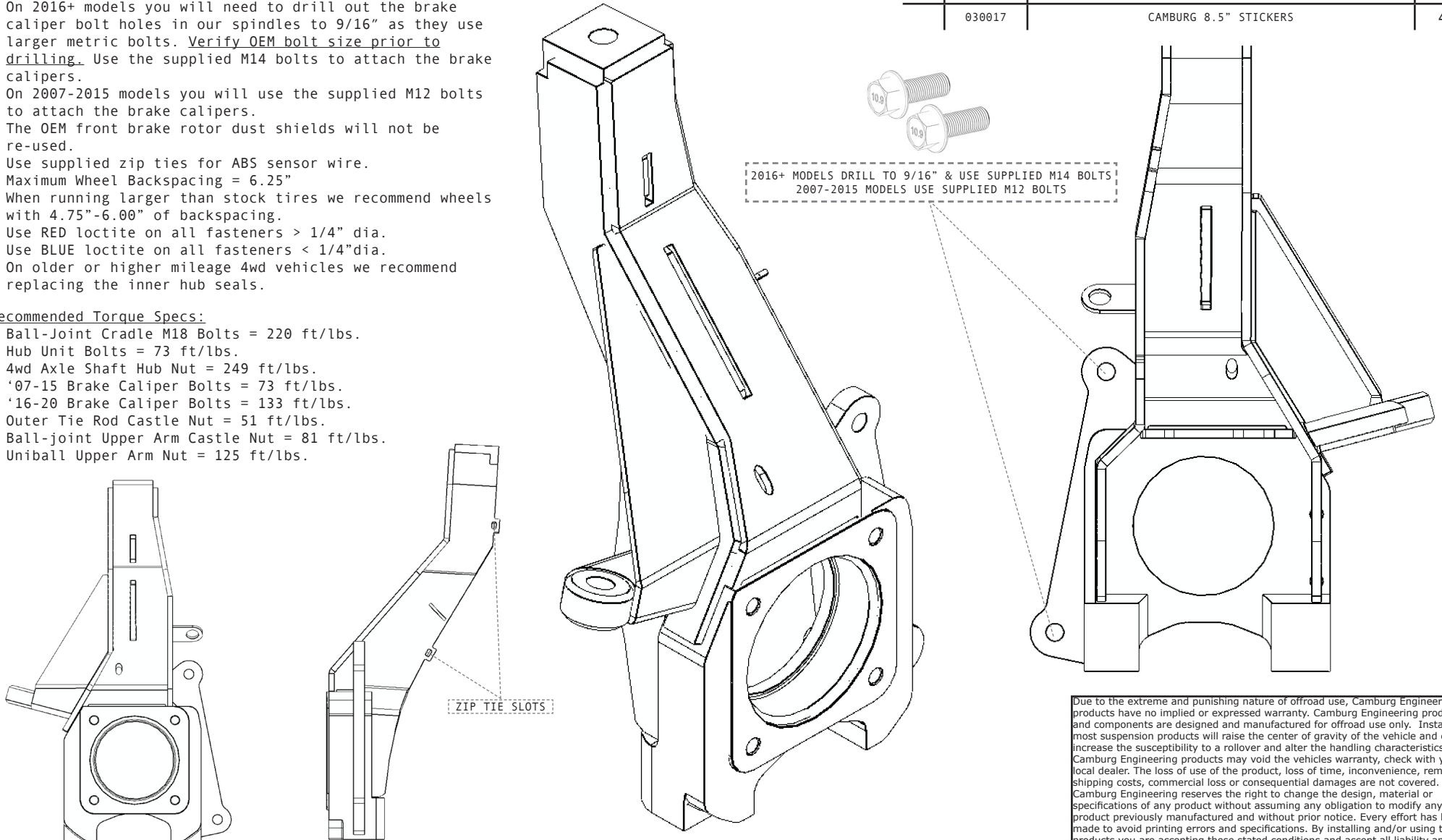

[09.28.20]

Due to the extreme and punishing nature of offroad use, Camburg Engineering products have no implied or expressed warranty. Camburg Engineering products and components are designed and manufactured for offroad use only. Installing most suspension products will raise the center of gravity of the vehicle and can increase the susceptibility to a rollover and alter the handling characteristics. Camburg Engineering products may void the vehicles warranty, check with your local dealer. The loss of use of the product, loss of time, inconvenience, removal, shipping costs, commercial loss or consequential damages are not covered. Camburg Engineering reserves the right to change the design, material or specifications of any product without assuming any obligation to modify any product previously manufactured and without prior notice. Every effort has been made to avoid printing errors and specifications. By installing and/or using these products you are accepting these stated conditions and accept all liability and responsibility.