

## BILLET Performance Uniball Upper Arm Instructions

Ford Ranger 2wd/4wd 2024-2025

### PARTS SUPPLIED

QTY	Description	ID
4	FK 3/4" X 7/8" RHT Heim Joints	1
4	7/8-14 RHT Steel Jam Nuts	2
4	3/8-24 x 1.25" SHCS Allen Bolts	6
8	3/8" AN960 Washers	7
4	3/8-24 MS21042 Flanged Nuts	8
2	M14 x 2.0 Flanged Nyloc Nuts	5
4	Heim Spacers (Short   Outer)	3
4	Heim Spacers (Long   Inner)	4
2	1/2" Upper Domed Uniball Spacers	12
2	1/2" Tapered Uniball Spindle Adapters	13
2	1/2-20 x 4.5" 12pt Bolts	11
2	1/2" SAE Grade 8 Washers	14
2	1/2-20 Stover Lock Nuts	15
2	Uniball Cover Caps (press-on)	16
4	Uniball Cover Cap O-rings	17
1	#30 x 10" Fishing Line (for cap install only)	
4	Camburg 8.5" Stickers	

Thanks for purchasing a set of our KINETIK series billet upper arms for your vehicle. Please follow all instructions. If you are not installing these yourself have a qualified shop do so. These arms are designed for 1-3" of lift from coilovers and to be used with stock OEM spindles or Camburg performance spindles. These are NOT designed to be used with cheap spacer type lifts. Make sure to check the parts list to make sure you have every component prior to starting. Camburg Engineering has made every attempt to insure you receive the highest quality components in the most complete manner. This is a guide to help you through the process with recommended torque specs. It's your responsibility to ensure parts are being installed correctly using the correct tools and procedures. We recommend reviewing a service manual for more details.

#### Tools & Supplies Required

Eye Protection | Jack | Jack Stands | Small Cutter | Deburring Tool  
 Hammer | 2-3 lb. Mini Sledge Hammer | Rubber Mallet  
 1-1/4" Open-End Wrench | 21mm Socket & Wrench  
 18mm Socket & Wrench | 1/2" 12pt Socket | 3/4" Socket  
 5/16" Allen Wrench | 7/16" Socket | Torque Wrench  
 Blue Painters Tape | Brake Cleaner | Grease | Anti-seize | Red Loctite

#### 1.0 Setup

Park the vehicle on level ground and set the parking brake and chock both rear wheels. Jack up the front end from the chassis until the front tires are off the ground. Place jack stands under the front frame rails and set down. Make sure the vehicle is supported correctly and the front tires are still off the ground. Place the jack under the driver side lower arm and raise the tire 1/2", then remove the wheel while keeping jack under lower a-arm to support the suspension. Read these instructions start to finish before moving forward and review diagrams.

#### 2.0 Removal

Using a 18mm socket, loosen the upper ball-joint nut where it connects to the spindle but do not fully remove. With a mini sledge hammer strike the top of the spindle numerous times to release the ball-joint tapered stud. This can be a little difficult since it's a press fit, heating up the spindle to get it to expand will help if need be. Once the ball joint releases from the spindle, then remove the nut. This will allow you to position the upper arm and spindle out of the way. Make sure to position & support the spindle so that it doesn't pull on the brake line and on 4wd models that it doesn't pull out the inner CV or strain the CV boots and axles. Use a 18mm & 21mm wrench to loosen and remove the OEM upper a-arm bolts. Then remove the stock upper arm.

#### 3.0 Pre-Installation

You will need to remove the large under head washer from the OEM bolt that is pressed on. In a vise or on a table, use a hammer and tap off the washer. You will not reuse the washer or the OEM nut. We recommend putting blue painters tape on the billet arms for protection during installation. Thread the 7/8" jam nuts onto the heims then apply anti-seize compound on the exposed threads. Thread the heims into the upper arm so the heim is vertical and the jam nut makes contact with the arm and you have 3 threads exposed past the nut.

Install the 3/8" allen heim pinch bolts and washers into the arm. With a drop of red Loctite on the nut, tighten and torque to 20-22 ft/lbs. Use a 1-1/4" open-end wrench to fully tighten the jam nut using another wrench to hold the heim vertical (perpendicular to the arm) so it doesn't rotate. See diagram for reference.

Now install the heim pivot spacers first coating the surface that slips into the heim with anti-seize. Install the shorter spacers towards the outside of the heims and the longer spacers towards the inside. See diagram for reference.

Using a countersink bit or deburring scraper tool, slightly chamfer the top-hole edge of the ball-joint taper in the spindle. This will allow the spacer to fully seat when tightened and eliminate possible stress risers. Then inspect and clean the tapered hole. See diagram for reference.

#### 4.0 Installation

Install the driver side Camburg upper arm onto the frame using the original bolt in the same orientation as it was removed. To insure you're installing the correct arm, the longer a-arm leg is towards the front of the vehicle along with the Camburg logo. With the bolt pushed all the way through, clean the threads with brake cleaner and once dry apply a little red Loctite to the nut area. Using a 18mm wrench and 21mm socket, torque the supplied M14 nyloc nut to 90 ft/lbs. Cycle the arm up and down to make sure there are no clearance issues. See diagram for reference.

Inspect and clean the tapered hole in the spindle/knuckle. Apply anti-seize to the uniball spacers and insert the tapered lower uniball spacer into the uniball. Then install the upper spacer into the top of the uniball making sure both spacers are fully seated. If not, damage will occur in the following steps. Install the 1/2" 12pt bolt through the spacers and uniball and attach the upper arm to the spindle by swinging it down to the spindle with some finesse. You may need to jack up the lower arm and move the uniball joint. The tapered spacer should sit almost flush with the top of the spindle before tightening. Make sure the lower spacer did not pull out slightly from the uniball or damage will occur as the spacer can get caught on the bearing race. Install the 1/2" washer and stover lock nut with a small amount of red Loctite onto clean threads. Using a 1/2" 12pt socket and 3/4" socket, torque to 85-90 ft/lbs. Do not over-tighten or use an impact gun. See diagram for reference.

Lastly install the cap by first installing one of the supplied o-rings into the caps lower groove. Then apply a small amount of grease to the inside of the top of the cup. Use the supplied 30# fishing line and insert 2" of it into the upper arm cup This will be used to release the trapped air as the cap is pressed on. Position and center the cap with the Ironman logo in your desired position. Cover the cap with a rag to protect the finish and use a rubber mallet to tap the cover in if not by hand. Make sure to apply even pressure so that it presses in straight.

\*\* REFER TO EXPLODED CAD DRAWING ON \*\*  
 \*\* OTHER SIDE FOR PARTS REFERENCE NUMBERS \*\*

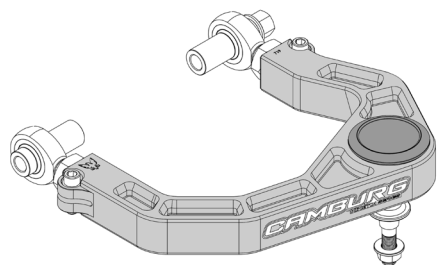

Due to the extreme and punishing nature of off-road use, Camburg Engineering products have no implied or expressed warranty. Camburg Engineering products and components are designed and manufactured for off-road use only. Always inspect your suspension after off-roading and at your routine service intervals. Use of products sold by Camburg Engineering is at the consumer's own risk. Proper installation and proper use of all products must be followed for optimal safety and performance. Camburg Engineering does not accept responsibility for improper use, alterations, lack of maintenance/inspection and installation of any products. Installing most suspension products will raise the center of gravity of the vehicle and can increase the susceptibility to a rollover and alter the handling characteristics. Camburg Engineering products may void the vehicles warranty, check with your local dealer. The loss of use of the product, loss of time, inconvenience, removal, shipping costs, commercial loss or consequential damages are not covered. Camburg Engineering reserves the right to change the design, material or specifications of any product without assuming any obligation to modify any product previously manufactured and without prior notice. Every effort has been made to avoid printing errors and specifications. By purchasing, installing and/or using these products you are accepting these stated conditions and accept all liability and responsibility.



# BILLET Performance Uniball Upper Arm Instructions

Ford Ranger 2wd/4wd 2024-2025

When the cap is fully seated and you hear the air escape, pull the fishing line out and make sure the cap is tight to the cup. Twist the cap a few degrees to the right and left to help seat the cap and o-ring. Then install another o-ring between the cap and the arm. This will allow you to easily remove the cap by removing the o-ring and having a recess to grasp by hand or with a small plastic tool. Periodically check the caps to make sure they are fully seated after off-road use and remove temporarily after any pressure washing for moisture to dissipate.

### Repeat steps 1 through 4 to install passenger side arm

#### 5.0 Alignment

You will need to have your vehicle aligned by a qualified shop. Additional caster is built into the Camburg arms to correct alignment issues that are inherent with lifting the vehicle. Have your alignment shop increase positive caster, then set camber and toe to factory OEM specifications. Having an increase in caster helps with straight line stability and cornering precision for performance driving on and off-road.

#### 6.0 Maintenance & Care

Use mild soap and water to clean the anodized aluminum surfaces, using chemicals can stain/dis-color the finish. Uniballs and heims are precision parts with tight tolerances which can lead to occasional noise when they become dirty. Occasionally wipe off the heims and underside of the uniball with a clean rag to remove road grime and dirt. Cleaning and lubricating them with WD-40 or a PTFE dry film lube like Super Lube can minimize any noise from stiction. Do not use harsh chemicals or grease/oil that attracts dirt to clean & lubricate the uniball as it will damage and wear the PTFE liner that is bonded internally. You will also need to occasionally remove the uniball cover to clean the top-side of the uniball.

Neglecting care and upkeep will wear parts out faster.

Inspect and re-torque all hardware and components after the first 500 miles, inspect at your scheduled maintenance intervals and whenever using the vehicle off-road.

#### Notes

Recommended tire size: 285/70/17 (32-33 in.)

Recommended wheel size: 17 in.

Recommended wheel backspacing = 4.75 in.

Maximum wheel backspacing = 5.75 in.

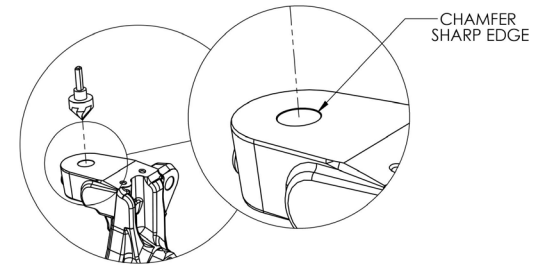
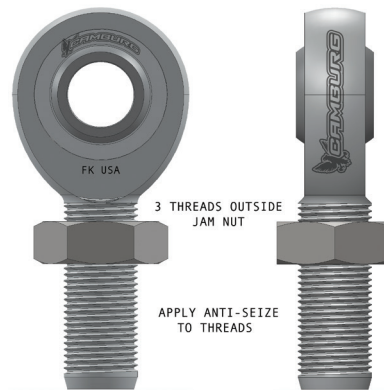
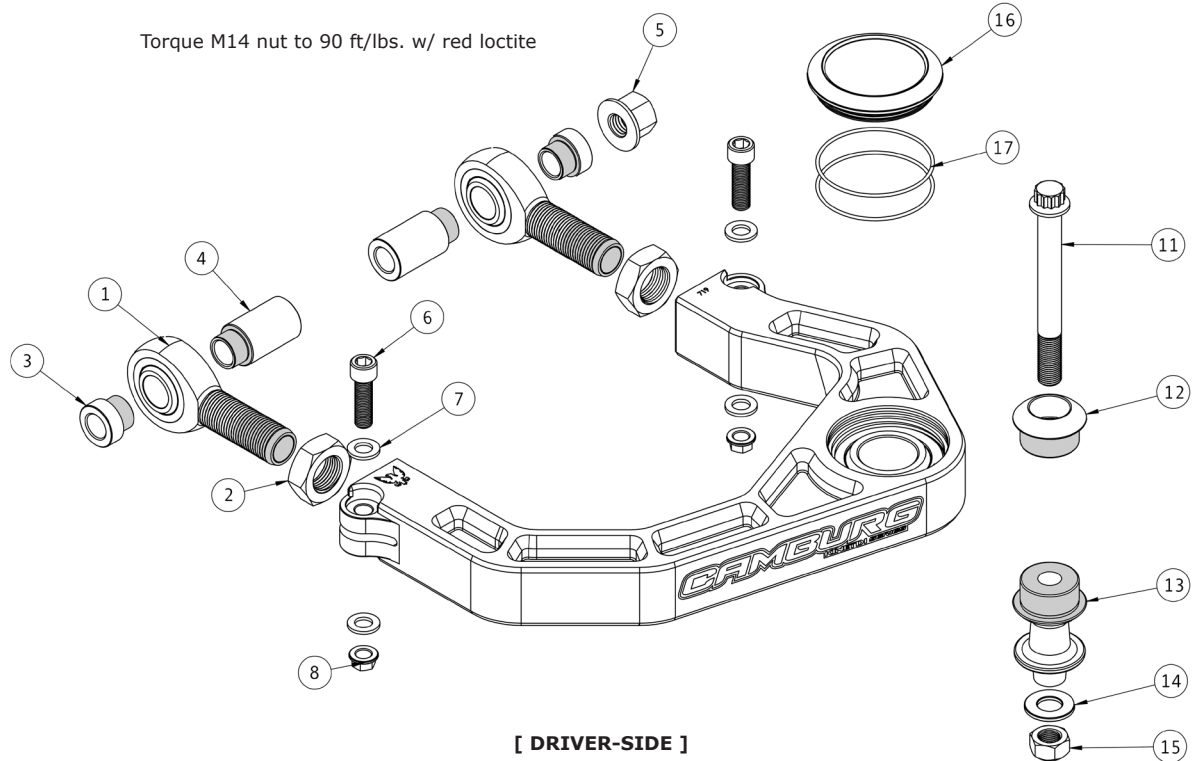

Due to the extreme and punishing nature of off-road use, Camburg Engineering products have no implied or expressed warranty. Camburg Engineering products and components are designed and manufactured for off-road use only. Always inspect your suspension after off-roading and at your routine service intervals. Use of products sold by Camburg Engineering is at the consumer's own risk. Proper installation and proper use of all products must be followed for optimal safety and performance. Camburg Engineering does not accept responsibility for improper use, alterations, lack of maintenance/inspection and installation of any products. Installing most suspension products will raise the center of gravity of the vehicle and can increase the susceptibility to a rollover and alter the handling characteristics. Camburg Engineering products may void the vehicles warranty, check with your local dealer. The loss of use of the product, loss of time, inconvenience, removal, shipping costs, commercial loss or consequential damages are not covered. Camburg Engineering reserves the right to change the design, material or specifications of any product without assuming any obligation to modify any product previously manufactured and without prior notice. Every effort has been made to avoid printing errors and specifications. By purchasing, installing and/or using these products you are accepting these stated conditions and accept all liability and responsibility.