



INSTALLATION INSTRUCTIONS



ACURA INTEGRA 2.0L

PART NO. 19696

BILL OF MATERIALS:

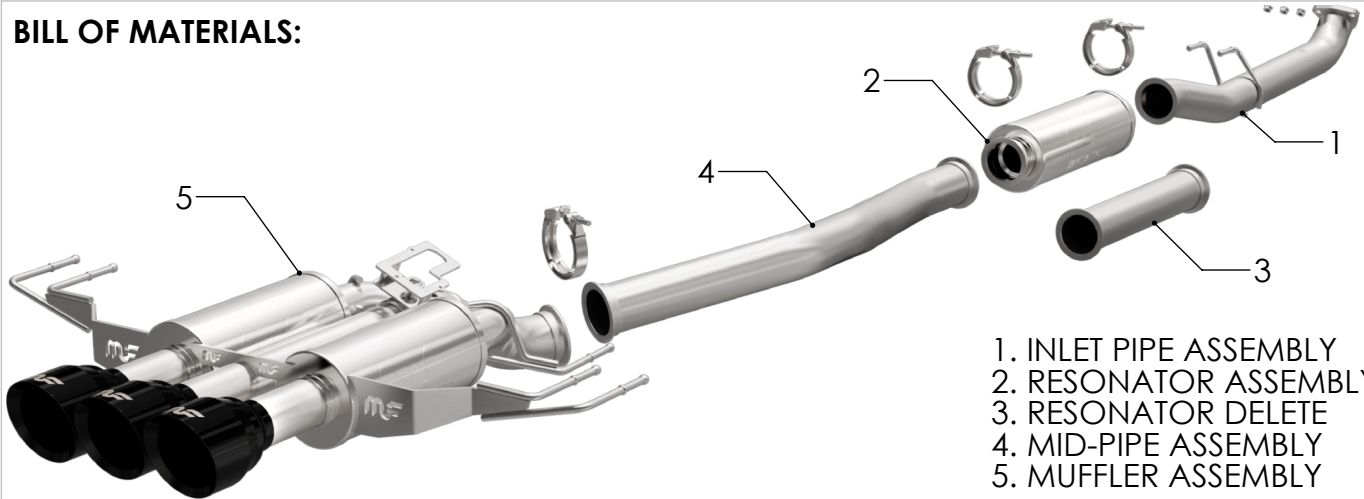

- 1. INLET PIPE ASSEMBLY
- 2. RESONATOR ASSEMBLY
- 3. RESONATOR DELETE
- 4. MID-PIPE ASSEMBLY
- 5. MUFFLER ASSEMBLY

SHOP SUPPLIES:

HARDWARE KIT:

- 1. [3] 3.00" V Clamp



WEAR SAFETY GLASSES



READ INSTRUCTIONS THOROUGHLY BEFORE INSTALLING PRODUCT



SPRAY LUBRICANT

To ease removal of existing exhaust components (especially on older vehicles) spray penetrating lubricant on all fasteners and hangers/insulators that will be loosened or removed and let soak before disassembly.

MINIMUM REQUIRED TOOLS:



14, 15, 10 mm



Hanger Tool (Or Pry Bar)

MAGNAFLOW RECOMMENDS PROFESSIONAL INSTALLATION ON ALL THEIR PRODUCTS



WARNING: When working on, under, or around any vehicle exercise caution. Please allow the vehicle's exhaust system to cool before removal, as exhaust system temperatures may cause severe burns. If working without a lift always consult vehicle manual for correct lifting specifications. Always wear safety glasses and ensure a safe work area. Serious injury or death could occur if safety measures are not followed.

ATTENTION: Always install any supplied band or U-bolt clamps to the proper torque specifications of 40-45 ft-lb for band clamps and 30-35 ft-lb for U-bolt clamps. Over tightening will result in the clamps breaking and will NOT be warranted by MagnaFlow.

MAGNAFLOW: 1901 Corporate Centre Dr - Oceanside, CA 92056 | 1(800)990-0905

Technical Support: 1(800) 959-9226 | Email: moreinfo@magnaflow.com

INSTALLATION INSTRUCTIONS

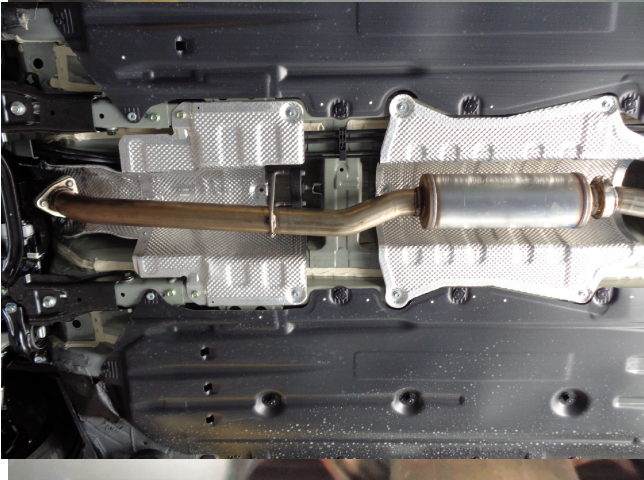

Step 1: Before removing the OEM exhaust system you will need to unplug the electrical connectors for both exhaust control valves. These are located on the vehicles tail pipes.



Step 2: To remove the OEM system first unbolt and remove the cross member at the inlet. Next, unbolt the inlet pipe at the catalytic converter flange junction. Working front to rear disengage all welded hangers from the rubber insulators. The OE exhaust system can now be removed in one piece. Be sure to retain all mounting hardware as it will be needed to install your new MagnaFlow system

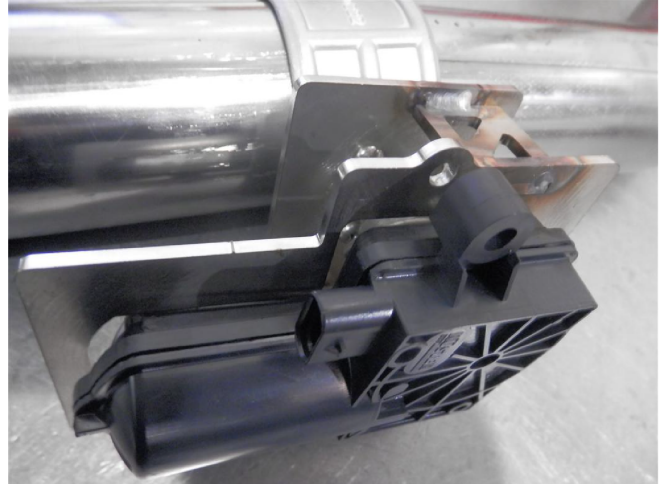

Step 3: Once the OEM exhaust system has been removed undo the three nuts attaching the exhaust valve motor to the valve and remove it. Before installing your new exhaust system attach the OEM valve motor to the MagnaFlow valve using the supplied hardware. The alignment spring on the motor will need to be engaged into the keyway slot of the new valve.

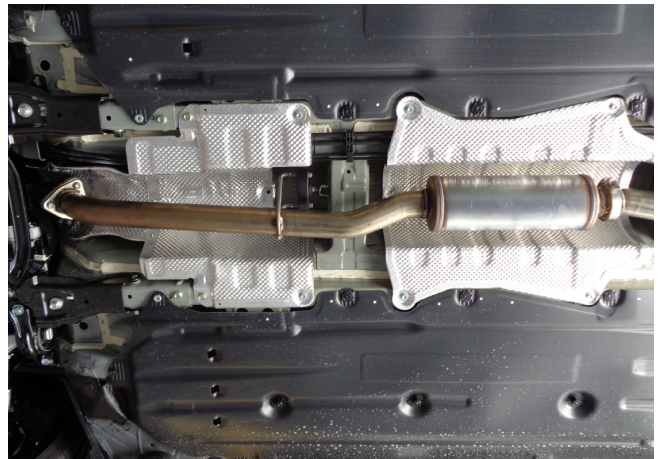

Step 4: *MagnaFlow supplies this kit with a Delete pipe, it can be used in place of the Resonator for a more aggressive sound.*

Begin installing your new system by loosely fastening the flange of the Inlet Assemblies to the catalytic converter outlet using the OEM hardware. Engage the welded hangers into the rubber insulator.

INSTALLATION INSTRUCTIONS

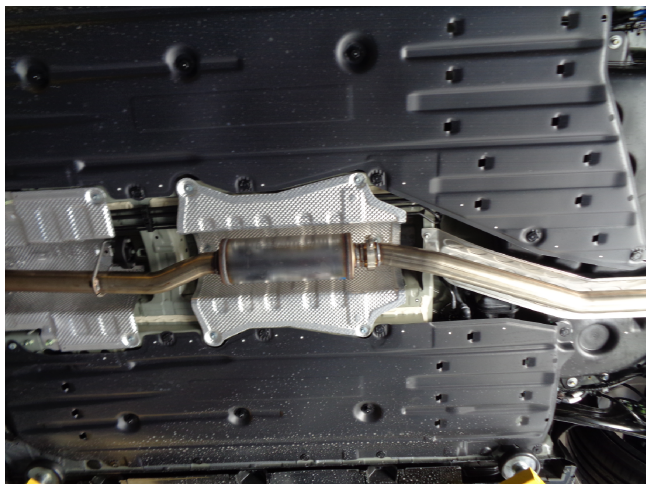

Step 5: Next, loosely fasten either the Resonator Assembly or the Delete Pipe to the Inlet Assembly using the supplied clamps.



Step 6: Finish by loosely installing the Mid Pipe and Muffler Assembly using the supplied clamp and fitting the hangers into the rubber insulators.



Step 7: Once a final position has been chosen for the new exhaust system, evenly tighten all clamps from front to rear using the torque specifications on page one of these instructions. Inspect all fasteners after 25-50 miles for operation and re-tighten if necessary.