

# S5512P

1997-1999 JEEP WRANGLER (TJ),  
2.5L/4.0L, CAT BACK, 2.5" SINGLE SIDE

# MBRP®

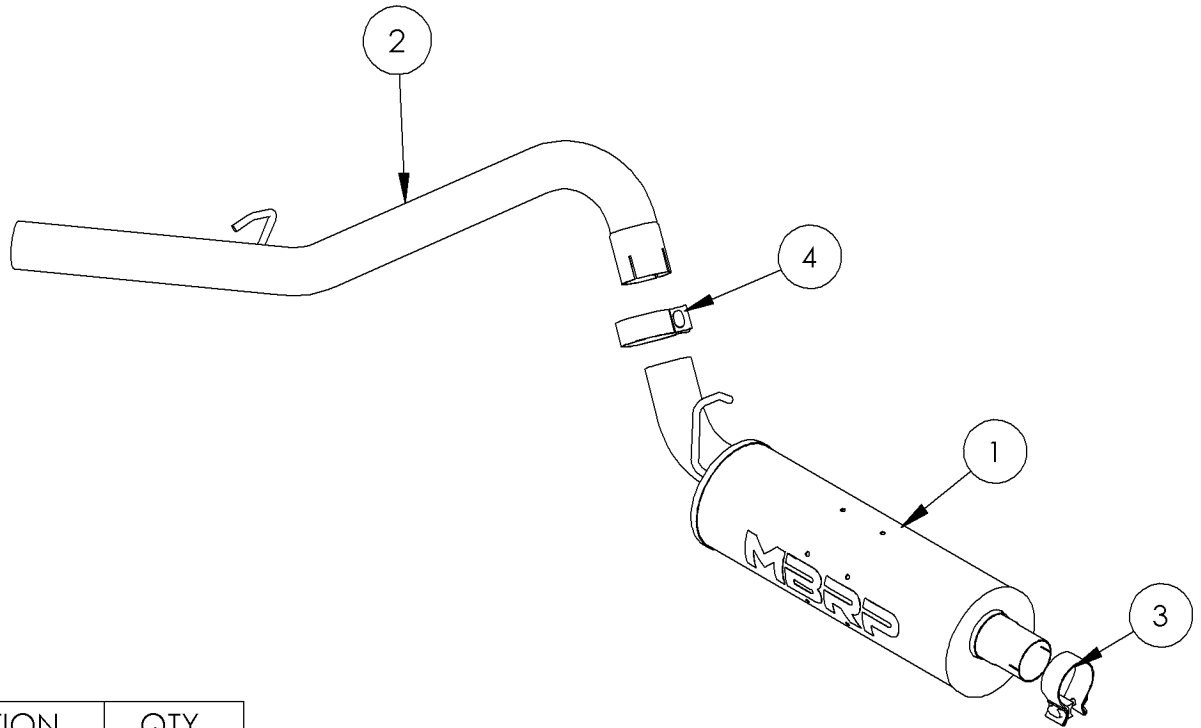

ITEM	DESCRIPTION	QTY.
1	MUFFLER	1
2	TAIL PIPE	1
3	2.25" CLAMP	1
4	2.5" CLAMP	1

## PLEASE READ BEFORE STARTING INSTALLATION

**While MBRP has made every effort to ensure that all components of this system are of superior quality and properly packaged, it is the installer's responsibility to ensure the following before removal of the factory exhaust:**

- that ALL components shown above are present.
- that ALL mating components fit together.
- that there are no damaged components.
- that the system you have purchased is appropriate for your vehicle year, model and configuration.
- that the system will not interfere with any modifications previously installed or planned.
- that you have read and understand these instructions.

If you have any questions or are uncertain about any aspect of the installation of this system to your vehicle please contact your dealer before commencing installation.

# MBRP<sup>®</sup>

## Removal of stock system:



**Figure 1**

1. Apply a penetrating lubricant liberally to all exhaust fasteners, hangers and rubber insulators.
2. Cut the exhaust pipe after the muffler to be able to remove it from the vehicle. **Refer to Figure 1.**
3. Remove the tail section of the exhaust by removing it from the rubber isolators. **Refer to Figure 2.**
4. Remove the clamp at the rear of the catalytic converter and remove the muffler from the vehicle.



**Figure 2**

## Installation of MBRP Performance Exhaust:

1. Install the **Muffler** to the catalytic converter using the 2 ¼" **Clamp**. Slide the **Muffler** hanger into the existing rubber isolator.
2. Slide a 2 ½" **Clamp** over the **Muffler** outlet then install the **Tail Pipe** to the **Muffler**. Install the **Tail Pipe** hanger into the existing rubber isolator. **Refer to Figure 3.**



**Figure 3**

3. Tighten all hardware and clamps, starting at the front and working rearward to secure the system. Check along the full length of the exhaust system to ensure there is adequate clearance for fuel lines, vent lines, brake lines, frame, bodywork, suspension and any wiring, etc. If there is any interference detected, relocate or adjust to provide adequate clearance. Ensure all clamp connections are secure and components are unable to rotate or slide. Band clamps require approximately 45 lb-ft (60 N-m) of torque. Verify clearances, system security and band clamp torque after 30- 60 miles (50-100 km) of driving.

**Congratulations!** You are ready to begin enjoying the improved performance and driving experience of your **MBRP** Performance Exhaust system. We hope you enjoy your purchase!