

S5043P

2015-2020 CHEV/GMC/CADILLAC
SUBURBAN/YUKON XL/ESCALADE ESV,
TAHOE/YUKON/ESCALADE, 5.3L/6.2L,
CAT BACK, 3", SINGLE SIDE

MBRP®

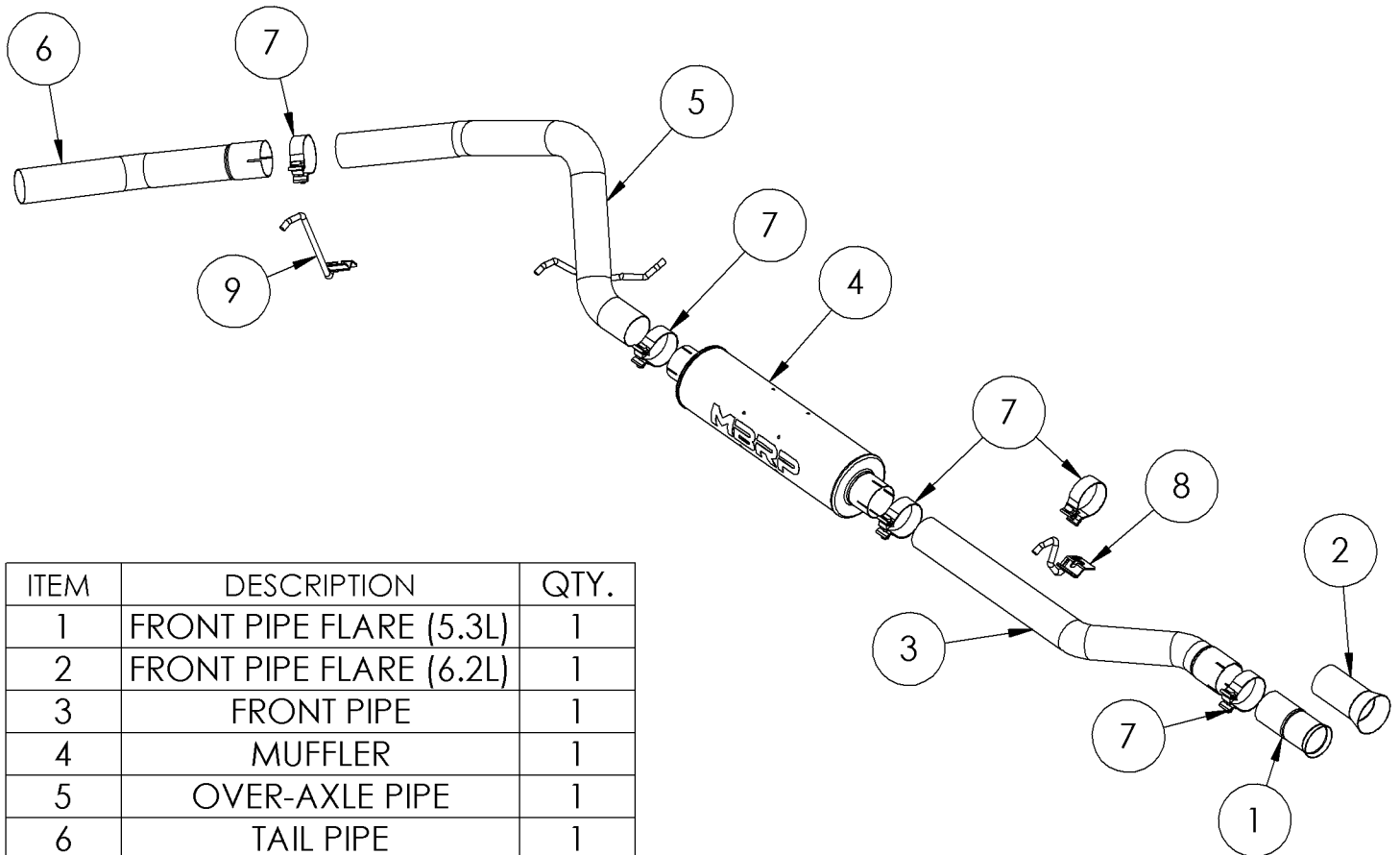

ITEM	DESCRIPTION	QTY.
1	FRONT PIPE FLARE (5.3L)	1
2	FRONT PIPE FLARE (6.2L)	1
3	FRONT PIPE	1
4	MUFFLER	1
5	OVER-AXLE PIPE	1
6	TAIL PIPE	1
7	3.0" CLAMP	5
8	HANG TIGHT™ HANGER	1
9	HANG TIGHT™ HANGER	1

PLEASE READ BEFORE STARTING INSTALLATION

While MBRP has made every effort to ensure that all components of this system are of superior quality and properly packaged, it is the installer's responsibility to ensure the following before removal of the factory exhaust:

- that ALL components shown above are present.
- that ALL mating components fit together.
- that there are no damaged components.
- that the system you have purchased is appropriate for your vehicle year, model and configuration.
- that the system will not interfere with any modifications previously installed or planned.
- that you have read and understand these instructions.

If you have any questions or are uncertain about any aspect of the installation of this system to your vehicle please contact your dealer before commencing installation.

MBRP

Removal of Stock System

1. Apply a penetrating lubricant liberally to all exhaust fasteners, hangers, and rubber isolators.
2. Remove the clamp after the catalytic converter and save the clamp as it will be reused during the installation.

Refer to Figure 1.

3. The tail pipe must be cut to remove the exhaust from the vehicle. To avoid cutting, properly support the rear axle and disconnect the passenger-side sway bar end link followed by the Panhard bar on the same side. This will allow the axle to sag low enough when weight is lifted off the axle to allow for the tail pipe and resonator to clear the axle.

Refer to Figure 2.

4. Remove the hangers from the rubber isolators and remove the exhaust from the vehicle. Reconnect any disconnected suspension components.

Installation of MBRP Performance Exhaust

1. Install the appropriate **Front Pipe Flare** (according to your vehicle's engine) onto the existing flange using the OEM clamp removed earlier.

Refer to Figure 3.

2. Install the **Front Pipe** onto the **Front Pipe Flare** using a **3.0" Band Clamp**. The **Front Pipe** will require cutting for Tahoe, Yukon, and Escalade models (116.0" wheelbase).

Refer to Figure 4.



Figure 1



Figure 2



Figure 3



Figure 5

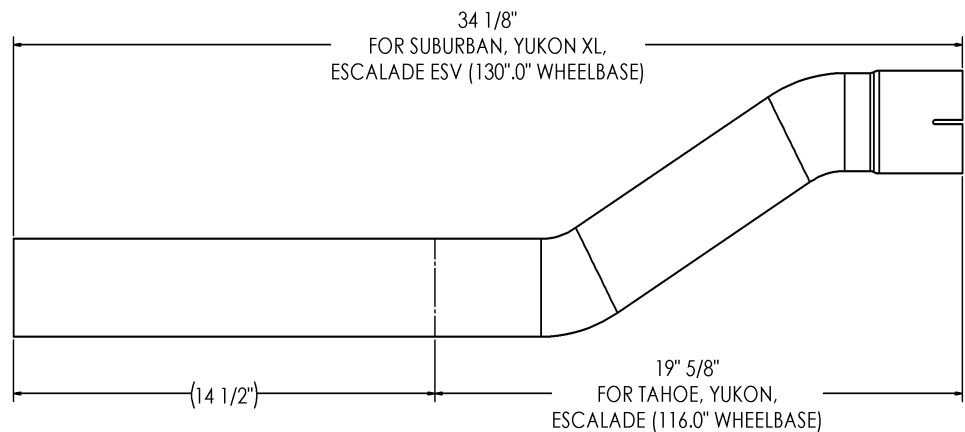

Figure 4

MBRP



Figure 6

3. For long wheelbase configurations (Suburban, Yukon XL, Escalade ESV), install the **Hang Tight™ Hanger** onto a **3.0" Band Clamp** using the procedure shown below. (Hang Tight™ Hanger not exactly as shown). This **Hang Tight™ Hanger** is not required for short wheelbase models.

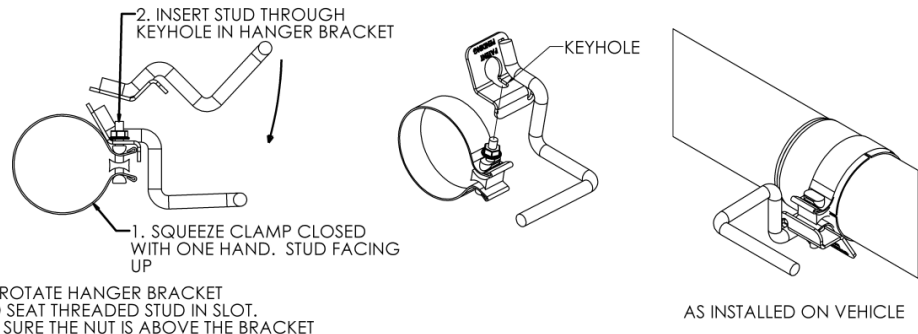

Figure 7

4. Install the previously assembled **Hang Tight™ Hanger** over the **Front Pipe** and into the OEM rubber isolator.
Refer to Figure 5.
5. Install the **Muffler** onto the end of the **Front Pipe** using a **3.0" Band Clamp**.
Refer to Figure 6.
6. Slide a **3.0" Band Clamp** onto the rear of the **Muffler**. Feed the **Over-Axle Pipe** into place from the front and install into the **Muffler**. Install the hangers on the **Over-Axle Pipe** onto the factory rubber insulators.
Refer to Figure 7.



Figure 8

7. Install the **Tail Pipe** onto the **Over-Axle Pipe** using the second **Hang Tight™ Hanger** clamp assembly. Install the **Hang Tight™ Hanger** into the factory rubber isolator.
Refer to Figure 8.
8. Align the edge of each band clamp with the edge of the joint it is connecting. Tighten all hardware and clamps, starting at the front and working rearward to secure the system. Check along the full length of the exhaust system to ensure there is adequate clearance for fuel lines, vent lines, brake lines, frame, bodywork, suspension, and any wiring, etc. If there is any interference detected, relocate, or adjust to provide adequate clearance. Ensure all clamp connections are secure and components are unable to rotate or slide. Band clamps require approximately 45 lb-ft (60 N-m) of torque. Verify clearances, system security and band clamp torque after 30-60 miles (50-100 km) of driving.

Congratulations! You are ready to begin experiencing the improved power, sound and driving excitement of your **MBRP** performance exhaust system. We know you will enjoy your purchase.