

# AT-9544PT

## MUFFLER ASSEMBLY, 5"

2015-2021 POLARIS RANGER 570

2017-2022, 2026-UP POLARIS RANGER 500

2026-UP POLARIS RANGER 500

# MBRP

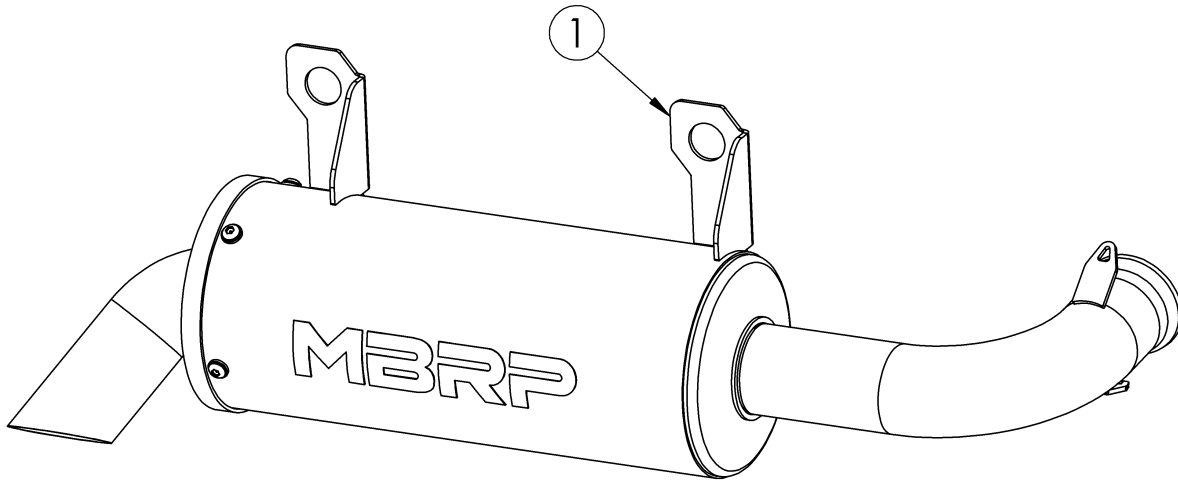

ITEM	DESCRIPTION	QTY
1	MUFFLER ASSEMBLY	1

Refer to this LOT NUMBER when contacting customer service: \_\_\_\_\_

## PLEASE READ BEFORE STARTING INSTALLATION

While MBRP Ltd. has made every effort to ensure that all components of this system are of superior quality and properly packaged, it is the installer's responsibility to ensure the following before removal of the factory exhaust:

- that ALL components shown above are present.
- that ALL mating components fit together.
- that there are no damaged components.
- that the system you have purchased is appropriate for your vehicle year, model and configuration.
- that the system will not interfere with any modifications previously installed or planned.
- that you have read and understand these instructions.

If you have any questions or are uncertain about any aspect of the installation of this system to your vehicle please contact your dealer before commencing installation.

# MBRP



Figure 1

## Removal of Stock Exhaust:

1. Remove the two (2) springs securing the muffler inlet. They will be reused.
2. Loosen the nuts securing the two (2) mounting brackets.
3. Remove the muffler from the vehicle by sliding the carriage bolts towards the driver-side and out of the mounting bracket slots.
4. Loosen and remove the hardware (nut, carriage bolt, washer) and rubber isolators from the muffler mounting brackets. They will be reused.

## Installation of MBRP Exhaust:

1. Install the rubber isolators and inner sleeve from the stock muffler into the mounting brackets of the new **Muffler Assembly**. Refer to Figure 1.
2. Ensure that the gasket is in place on the outlet of the front pipe.
3. With the carriage bolts placed into the vehicle mounts, position the inlet of the **Muffler Assembly** onto the stock gasket and install the mounting isolators onto the carriage bolts. Refer to Figure 2.
4. Loosely install the washers and nuts onto each carriage bolt to hold the muffler in place. Refer to Figure 2.
5. Reinstall the two springs at the muffler inlet, then fully tighten the mounting hardware. Refer to Figure 3.



Figure 2

It is recommended that the muffler screws (tip and endcap) be retightened after the first ride and checked periodically thereafter, tightening if necessary.



Figure 3



**Congratulations!** You are ready to begin experiencing the improved performance and driving excitement of your **MBRP** ATV Exhaust upgrade. We know you will enjoy your purchase.



**Figure 1**



**Figure 2**



**Figure 3**



**Figure 4**

## Spark Arrestor Maintenance

In order to maintain optimal performance, the spark arrestor screen should be cleaned after the first 3 hours of use. Afterwards, clean every 30-35 hours of use.

## Clean-out Instructions:

Make sure the vehicle is cool before completing the clean-out procedure.

1. Using a 4mm hex key, remove the 4 screws securing the outlet cap or tip. **(Figure 1)**
2. Remove the outlet cap to expose the spark arrestor screen insert. **(Figure 2)**
3. Remove the screen insert. **(Figure 3)**
4. Using a wire brush, thoroughly brush the screen to remove residue. **(Figure 4)**
5. Replace the screen and cap.
6. Tighten the screws to 60 in-lbs (6.8 Nm).