

# AT-9536PT

MUFFLER ASSEMBLY, PERFORMANCE  
2024-UP POLARIS RZR XP 1000

# MBRP®

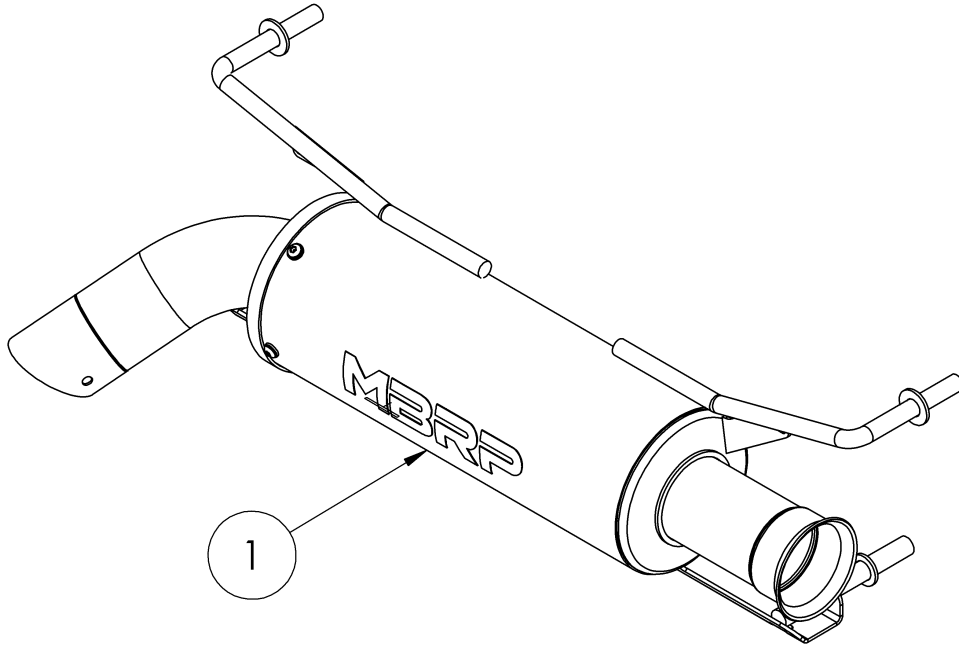

ITEM NO.	DESCRIPTION	QTY.
1	MUFFLER ASSEMBLY	1

Refer to this LOT NUMBER when contacting customer service: \_\_\_\_\_

## PLEASE READ BEFORE STARTING INSTALLATION

While MBRP has made every effort to ensure that all components of this system are of superior quality and properly packaged, it is the installer's responsibility to ensure the following before removal of the factory exhaust:

- that ALL components shown above are present.
- that ALL mating components fit together.
- that there are no damaged components.
- that the system you have purchased is appropriate for your vehicle year, model and configuration.
- that the system will not interfere with any modifications previously installed or planned.
- that you have read and understand these instructions.

If you have any questions or are uncertain about any aspect of the installation of this system to your vehicle please contact your dealer before commencing installation.

# MBRP

## Removal of Stock Exhaust:

\* **Retain all factory hardware for final installation.**

1. If equipped, remove the rear bumper.
2. Remove the four (4) fasteners securing the lower portion of the rear fascia. This will allow the panel to flex as needed to remove the stock muffler. **Refer to Figure 1.**
3. Loosen and remove the v-band clamp securing the muffler inlet to the exhaust pipe and disconnect the joint. Leave the gasket on the vehicle exhaust pipe. **Refer to Figure 2.**
4. Remove the two (2) springs (one on either side of the muffler body) that secure the muffler to the vehicle.
5. Remove the muffler by sliding the hangers rearward, out of the rubber isolators.
6. Remove the OEM spark arrestor from the stock muffler outlet. It will be reused.

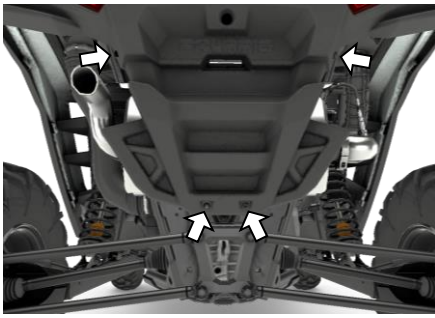

**Figure 1**

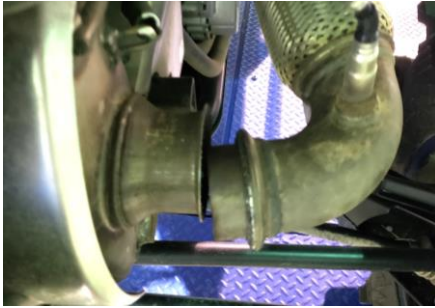

**Figure 2**

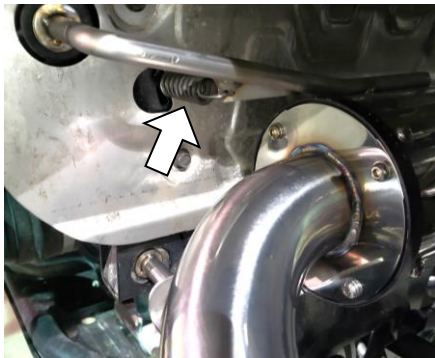

**Figure 3**



**Figure 4**



**Figure 5**

## Installation of MBRP Exhaust:

1. Slide the hanger rods into the rubber isolators on the vehicle and mate the **Muffler Assembly** inlet pipe to the end of the exhaust pipe.
2. Secure the **Muffler Assembly** by reinstalling the previously removed springs to the tabs attached to the top hanger rods. **Refer to Figure 3.**
3. Secure the inlet to the front pipe using the stock v-band clamp that was removed previously. **Refer to Figure 4.**
4. Install the OEM spark arrestor into the tip of the **Muffler Assembly**. **Refer to Figure 5.**
5. Reinstall the four (4) screws to secure the rear fascia and then reinstall the bumper.

*Note: In order to maintain optimal performance, the spark arrestor screen should be removed and cleaned after every 30-35 hours of use.*

It is recommended that the muffler screws be retightened after the first ride and checked periodically thereafter, tightening if necessary.



**Congratulations!** You are ready to begin experiencing the improved performance and driving excitement of your MBRP Exhaust upgrade. We know you will enjoy your purchase.