



ARMOR LITE SERIES

JT

**JEEP JT 4DR ARMOR LITE
SLIDERS**



WEB LINK: <http://lodoffroad.com/assets/pdfs/JRS2060 JT 4DR ARMOR LITE SLIDER.pdf>

***VERIFY YOU HAVE ALL THE COMPONENTS BEFORE STARTING THE INSTALLATION. REFER TO THE
ENGINEERING DRAWINGS AT THE END OF THIS DOCUMENT FOR A COMPLETE PARTS LIST***

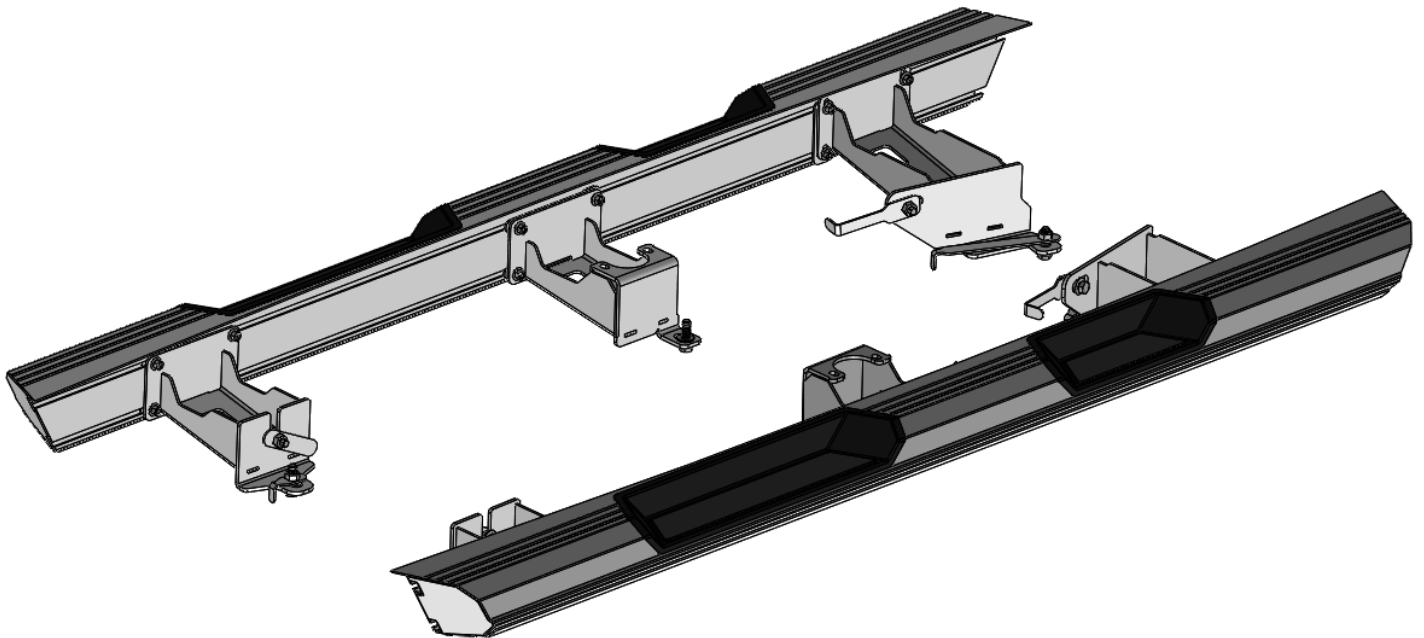

Refer to the Engineering drawing included with this document for the correct hardware required at each step of the installation.

Install the Rear Mounts as shown using 1/2" Hex Bolts and Washers. Use the supplied Flag Nuts inside the frame and tighten securely. It may be helpful to have a helper hold the mount while you assemble the bolts.

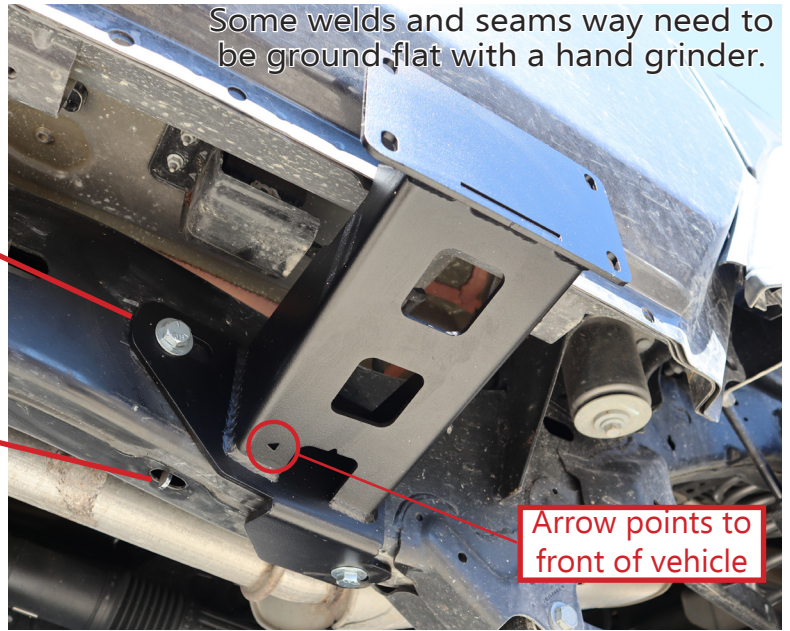
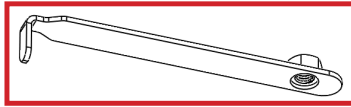
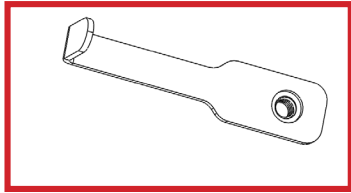

****Use the existing frame bolt on the passenger side for the lower mounting hole.****

Install the Center Mounts as shown using the two body isolator nuts "A" shown below. You may need to loosen the large center bolt slightly if the large washer is in the way, but do not remove it. ****Leave these nuts loose while you finish the installation. You will tighten up this mount in the end.****

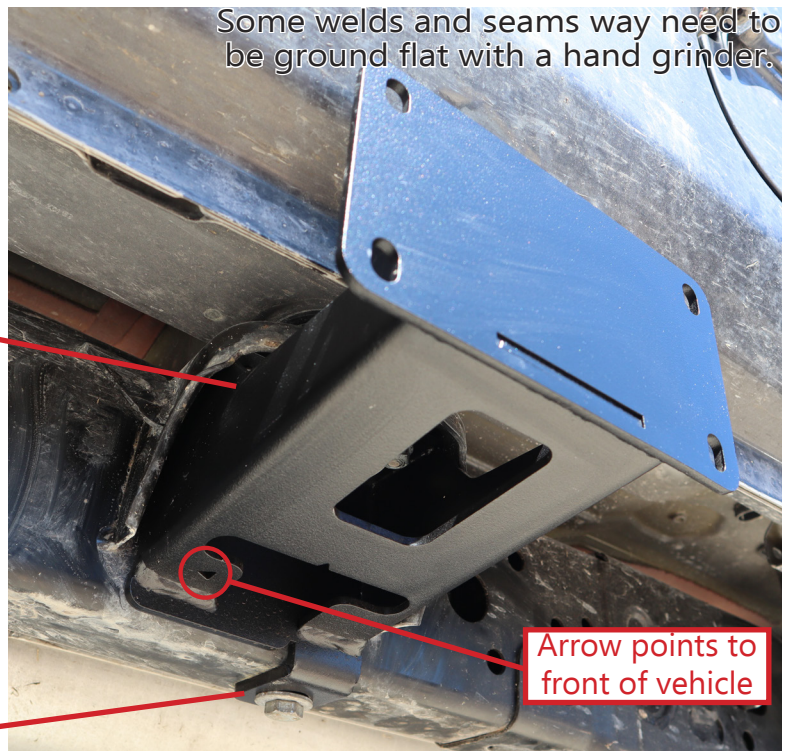
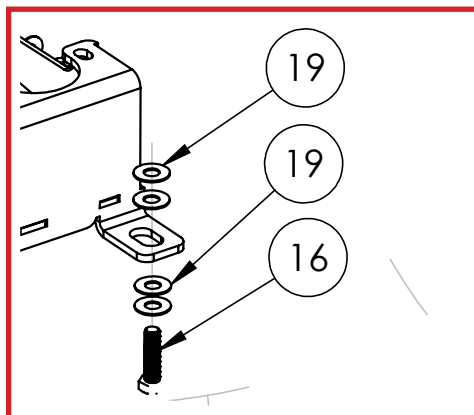
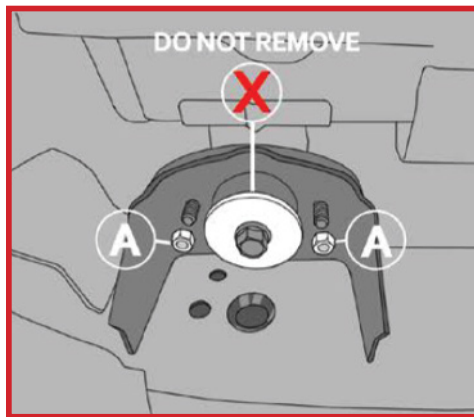

Install the M12 Hex Bolt as shown. You may double up the washers for extra strength. Every Jeep frame is slightly different. If you notice a small gap between the frame and the Center Mount lower tab, we include additional spacer washers to fill in this gap.

****Be sure to leave this bolt loose while you finish the installation. You will tighten this bolt in the end. ****

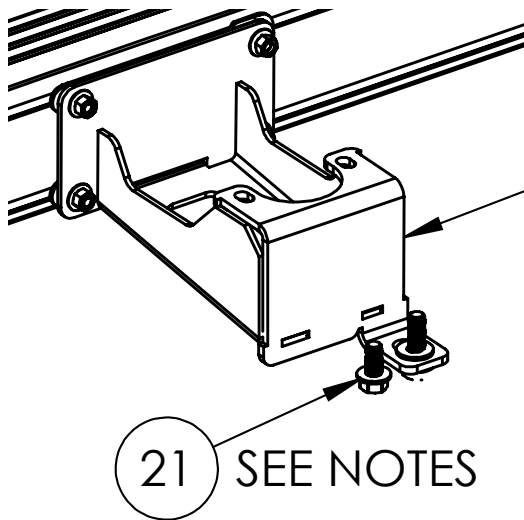

Optional mounting location

Some Gladiators may be missing a mounting hole for the center mount. This lower mounting hole is optional (on both passenger and driver side Center Mounts), but recommended for offroad use.

We have included two self tapping bolts to use in this location. Drill 7/16"Ø hole and insert the self tapping Thread Roller bolts provided. Slowly tighten until fully seated. Or if you prefer you may drill and tap for a 1/2" bolt (not provided).

****Be sure to leave this bolt loose while you finish the installation. You will tighten this bolt in the end. ****

On the passenger side, your center mount will use the same mounting hole as the gas tank skid plate. When you install the center mount, be sure the mounting tab sits over the gas tank skid plate as shown.

****Be sure to leave this bolt loose while you finish the installation. You will tighten this bolt in the end. ****

Do not lower your skid plate and attempt to mount inbetween the skid plate and the frame.

Mount over gas tank skid plate

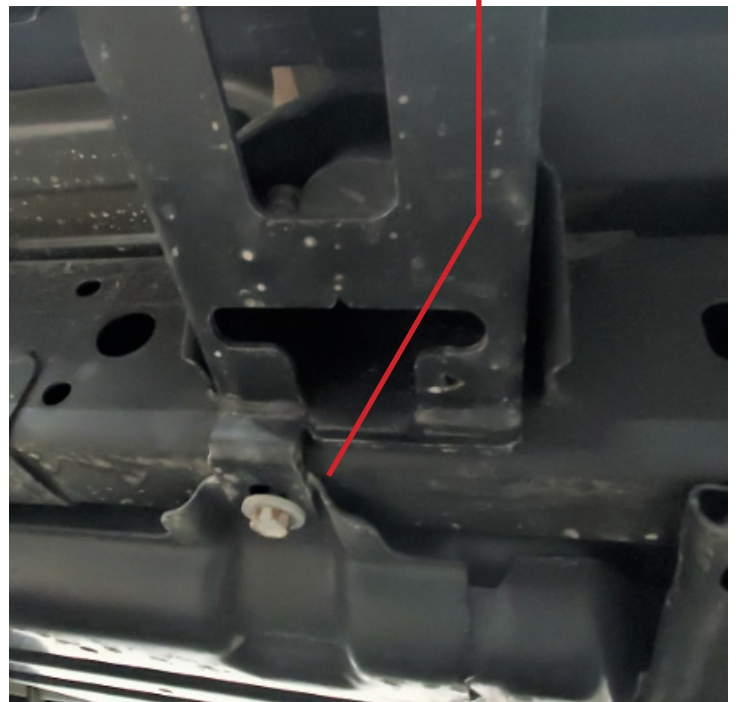

Install the front mount as shown. Install the 1/2" Hex Bolt and Washers onto the Flag Nut and insert into the large slot on the frame rail. Be careful not to drop the Flag Nut into the frame.

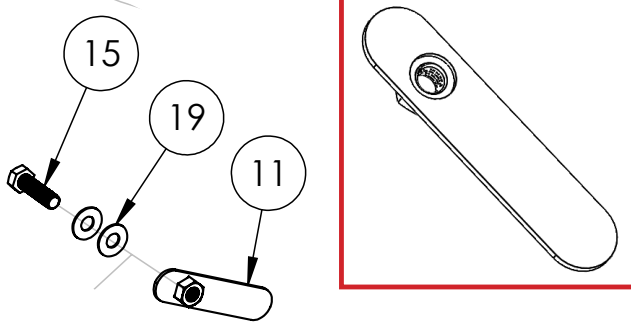

Using your first two fingers, hold the Hex Bolt and Washers. Tighten the Hex Bolt so there is just enough gap for your fingers. Then slide the Front Mount up into position while holding the Hex Bolt and Washers. Once in position tighten the Hex Bolt just enough to hold it in place.

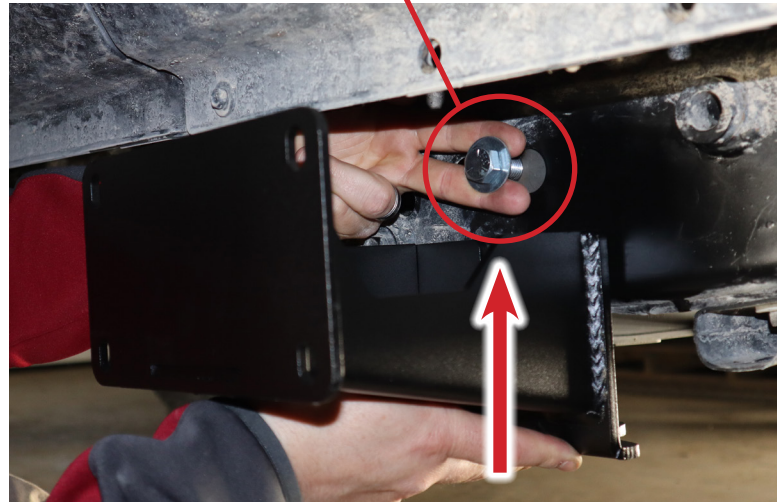
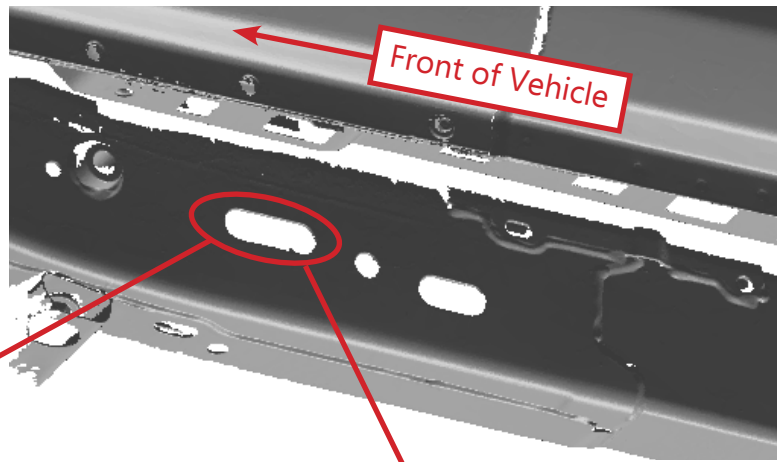

Install the lower Flag Nut into the frame rail and install the 1/2" Hex Bolt and Washers. Slowly tighten both Hex Bolts equally. Use a combination wrench or ratchet with a 3" extension to tighten the Hex Bolt in side of the frame rail.

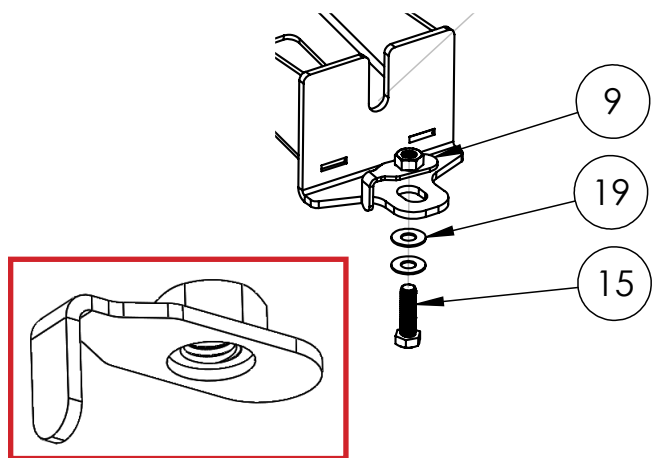

Hole in frame rail for Flag Nut



Before installing the passenger side Front Mount, you will need to remove the frame alignment tab on the side of the frame rail.



Use an angle grinder with a cutoff wheel to cutoff the alignment tab as close to the frame as possible.

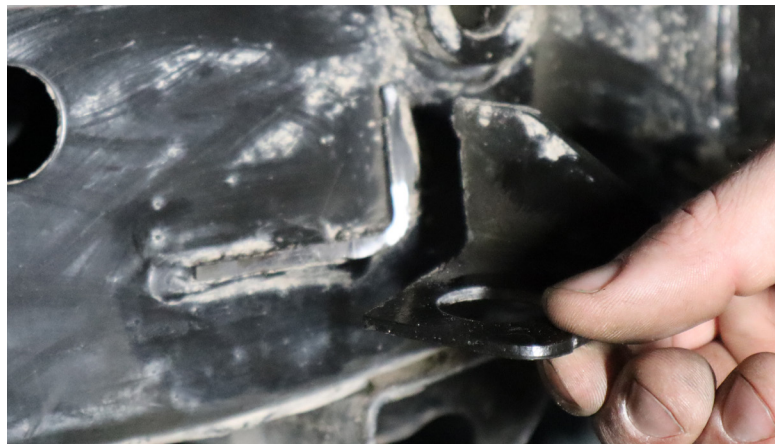

Use a flap disc or other grinding disk to grind the area smooth and flush with the frame rail. Clean the area and coat with a few good coats of Rustoleum Black spray paint before installing the front mount.



Install 6 Double Backup Plates with Carriage Bolts as shown into the T-Slots on the back of the Armor Lite Step Assembly.



Align the Double Backup Plates as shown in 3 pairs, front, center and rear. Line the bolts up with the holes in the Mounts and rotate the Step Assembly into place.

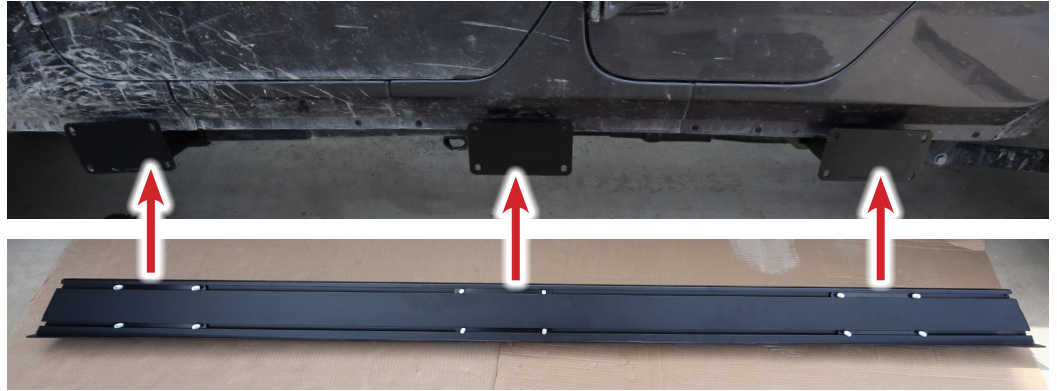

It is helpful to have a friend assist with this step to get all the bolts into the mounting holes at the same time. Once in place, loosely attach with Hex Nuts and Washers

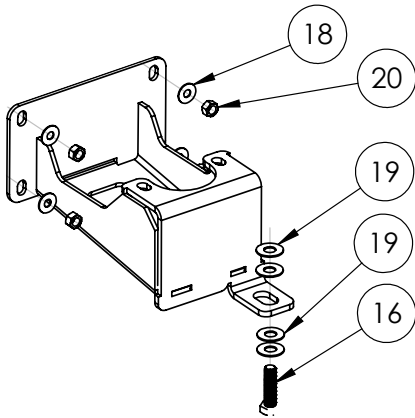
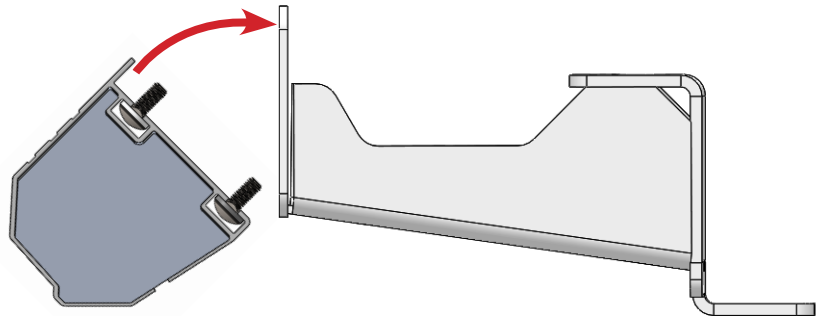



If necessary you can adjust the sliders slightly by rotating it, or moving up/down or forward/backward to get an even gap between back side of your sliders and your Jeep body.

Every Jeep is different and due to the Jeep manufacturing process, you might find that your slider is a little too close to the body of your Jeep. To resolve this we provide Shim Plates to help get the perfect gap. These plates can be installed without completely removing your slider. Simply loosen a few of the mounting bolts and slide the Shim Plate in where needed between the mount and back of the slider body.

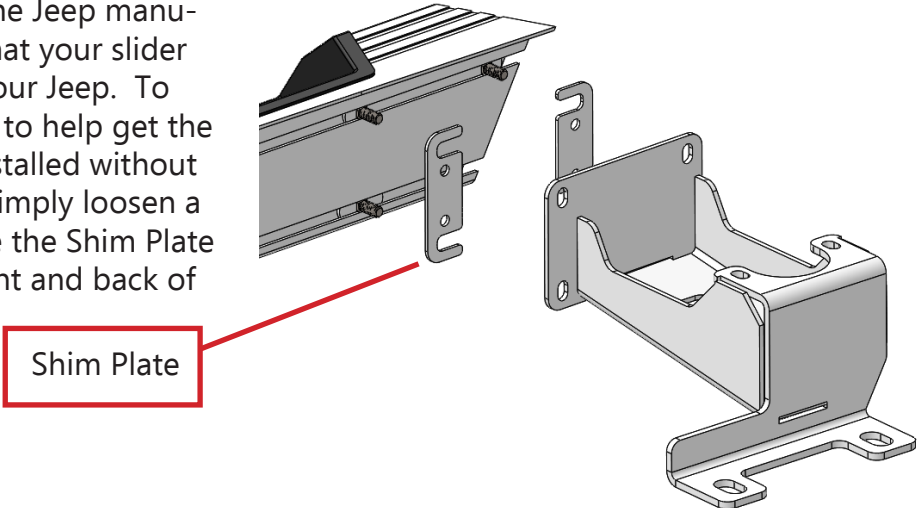

Once you have your slider in the correct position, tighten the four mounting nuts that mount the slider body to the Frame Mounts on the front and rear.

Then finish by tightening the Center Mount to the Slider Body and then tighten the Center Mount to the frame.

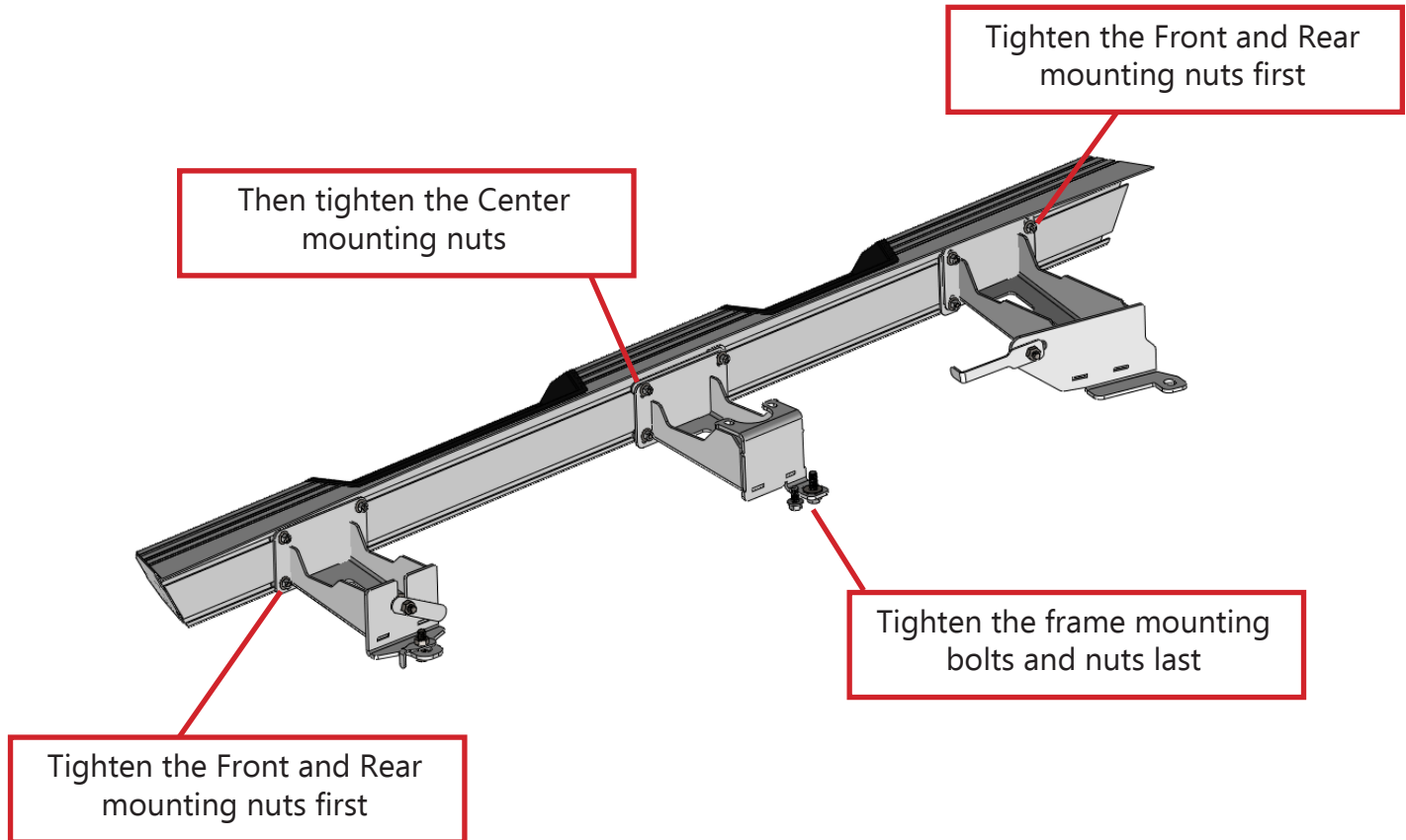

****Maintenance****

- Periodically check and re-tighten all fasteners.
- Periodically check your Armor Lite Sliders for scratches or dings which can happen over time or after heavy use or highway driving. It is important to address these areas as soon as possible to prevent flaking and corrosion or rust from spreading. We recommend using Rustoleum® brand Black Semi-Gloss Protective Enamel (oil based). Remove loose powder coating, sand the area and clean using alcohol. Apply using a foam brush by dabbing to match the powder coat texture.



ITEM NO.	PART NUMBER	DESCRIPTION	QTY.
1	4JRS2060-13	JT ARMOR LITE STEP ASSEMBLY - PS	1
2	4JRS2060-14	JT ARMOR LITE STEP ASSEMBLY - DS	1
3	4JRS2060-04	JT SLIDER FRONT MOUNT DS	1
4	4JRS2060-01	JT SLIDER FRONT MOUNT PS	1
5	4JRS2060-06	JT SLIDER REAR MOUNT DS	1
6	4JRS2060-03	JT SLIDER REAR MOUNT PS	1
7	4JRS2060-11	JT SLIDER CENTER MOUNT DS	1
8	4JRS2060-12	JT SLIDER CENTER MOUNT PS	1
9	4JRS1860-07	FRONT LOWER FLAG NUT	2
10	4JRS2060-07	REAR FLAG NUT	2
11	4JRS1860-08	FRONT FLAG NUT	2
12	4JRS2060-08	LOWER REAR FLAG NUT	1
13	2JRS1860-15	DOUBLE BACKUP PLATE	12
14	2JRS1860-29	MOUNT SHIM PLATE	6

HARDWARE

ITEM NO.	PART NUMBER	DESCRIPTION	QTY.
15	HB501328ZPGR5	HEX BOLT 1/2-13 X 1.75 HEX BOLT ZINC PLATE GR5	7
16	HB12150M45ZPCL88	HEX BOLT M12-1.50 X 45mm ZINC PLATE CL8.8	2
17	CB381616ZPGR5	CARRIAGE BOLT 3/8-16 X 1.00 ZINC PLATE GR5	24
18	FW3114ZP	FLAT WASHER Ø5/16" X .875" ZINC PLATE	24
19	FW4318ZP	FLAT WASHER Ø7/16" X 1.25" ZINC PLATED	22
20	HN3816ZPGR5	HEX NUT 3/8-16 ZINC PLATE GR5	24
21	TR501316ZP	THREAD ROLLER 1/2-13 X 1.00 HEX ZINC PLATE	2

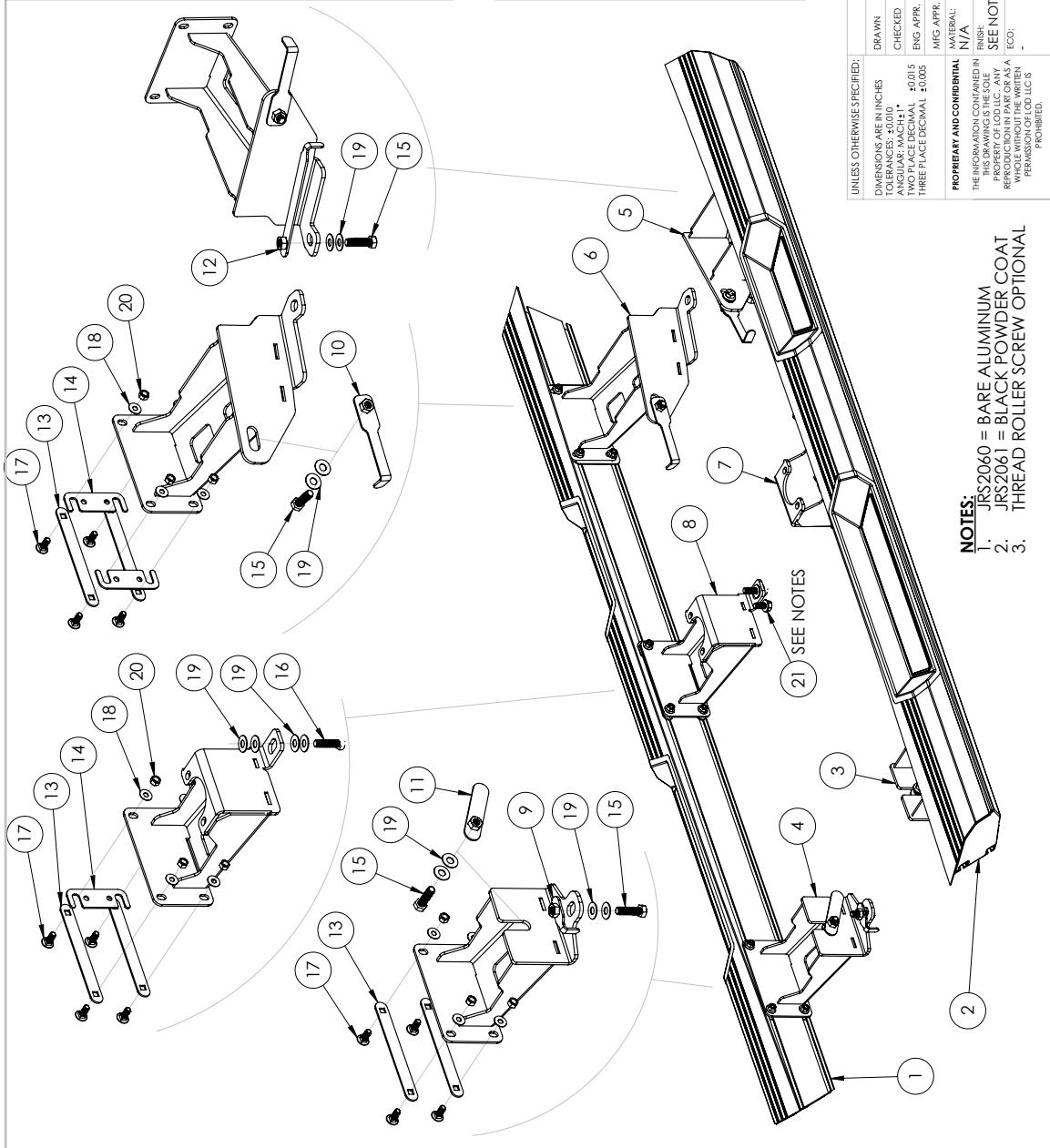

- NOTES:**
1. JRS2060 = BARE ALUMINUM
 2. JRS2061 = BLACK POWDER COAT
 3. THREAD ROLLER SCREW OPTIONAL

NAME	LOD LLC.
DATE	10/17/2020
MCH	
DRAWN	
CHECKED	
ANGULAR: MACH 1*	
ANGULAR: DIM 0.015	
THREE PLACE DECIMAL	
ENG. APPR.	
MFG. APPR.	
MATERIAL:	N/A
FINISH:	SEE NOTES
REPRODUCTION IN PART OR AS A	
WHOLE WITHOUT THE WRITTEN	
PERMISSION OF LOD LLC IS	
PROHIBITED.	

DESCRIPTION:
JEEP JT 4DR ARMOR LITE SLIDERS

DWG. NO. JRS2060
JRS2061

SCALE: 1:9 SHEET SIZE: B

REV B

SHEET 1 OF 1





JT Jeep
ARMOR LITE SERIES
 JEEP JT 4DR ARMOR LITE
 SLIDERS
 SHIPPING SHEET - BOX 1

Packaged by:

On:

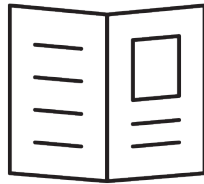

Instruction
Booklet

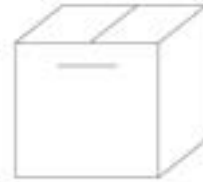

Hardware Kit

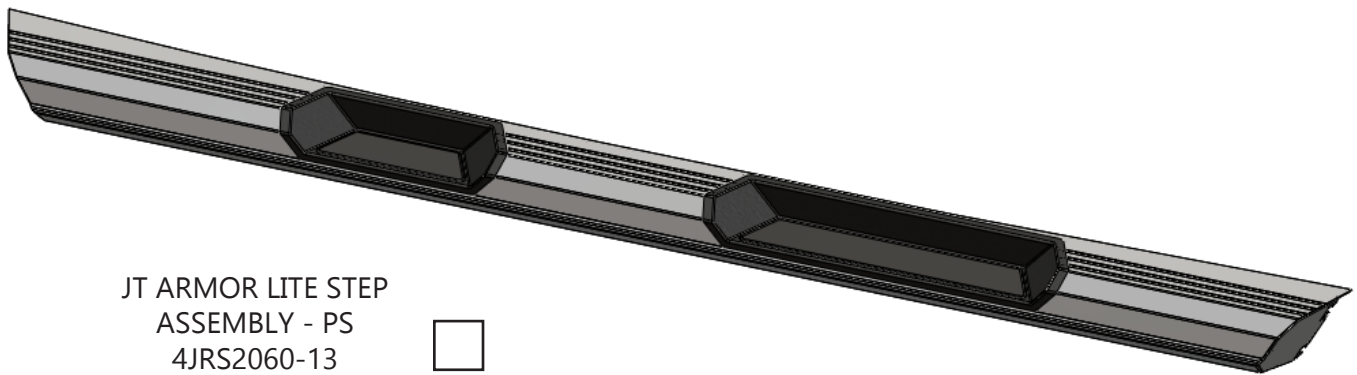

JT ARMOR LITE STEP
 ASSEMBLY - PS
 4JRS2060-13
(x1)

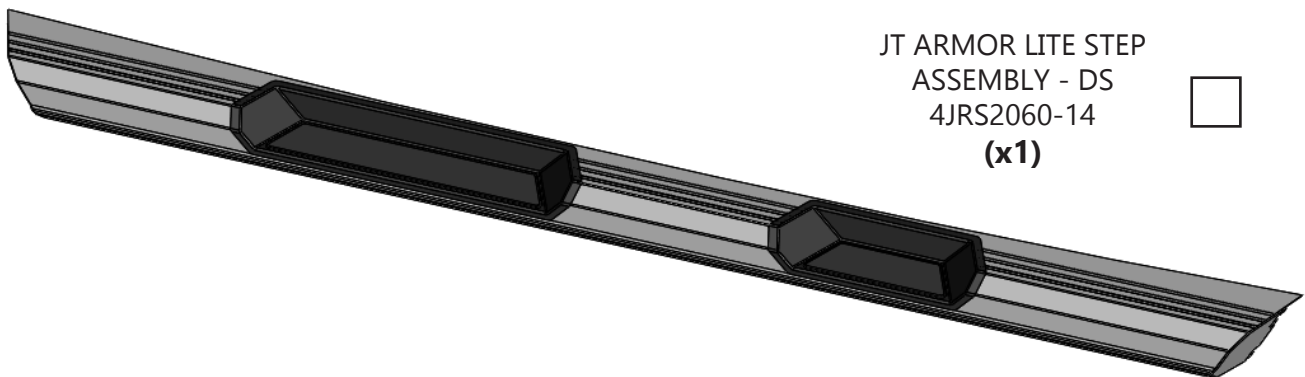

JT ARMOR LITE STEP
 ASSEMBLY - DS
 4JRS2060-14
(x1)





JT Jeep
DESTROYER/ARMOR LITE
 JEEP JT 4DR SLIDERS
 SHIPPING SHEET - BOX 2

Packaged by: _____

On: _____

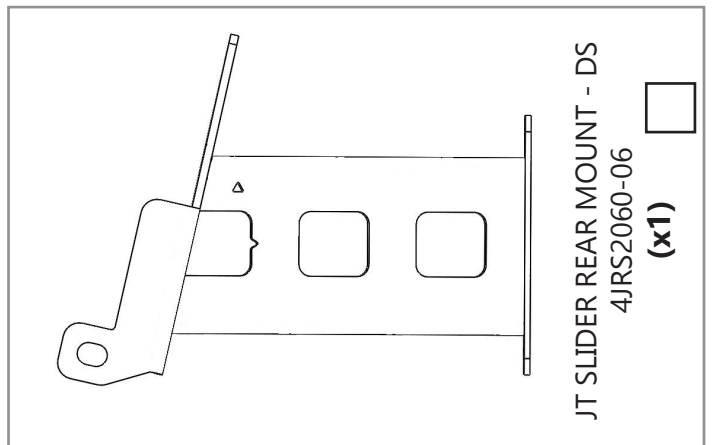
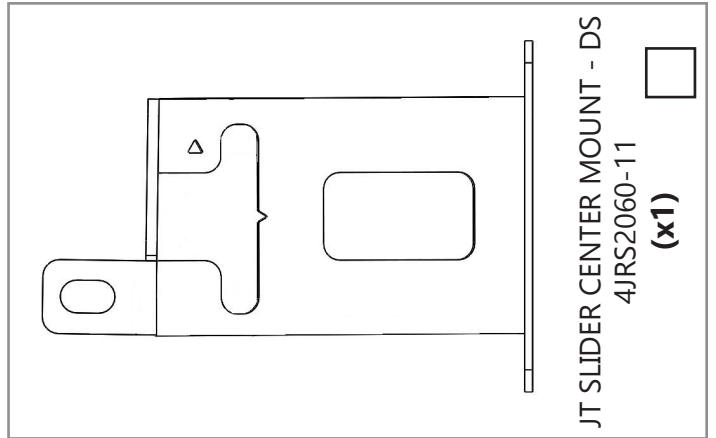
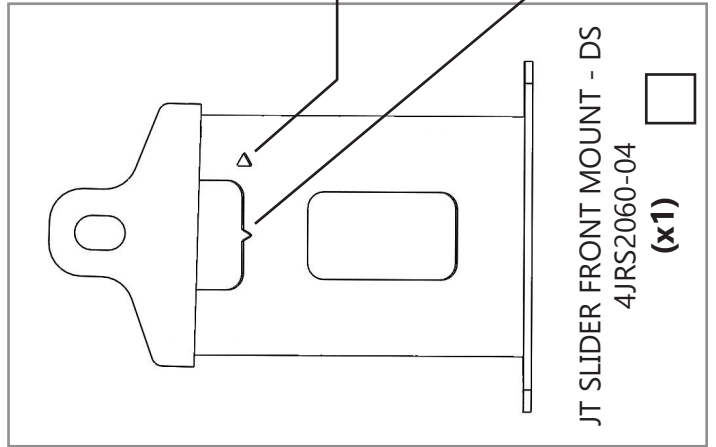
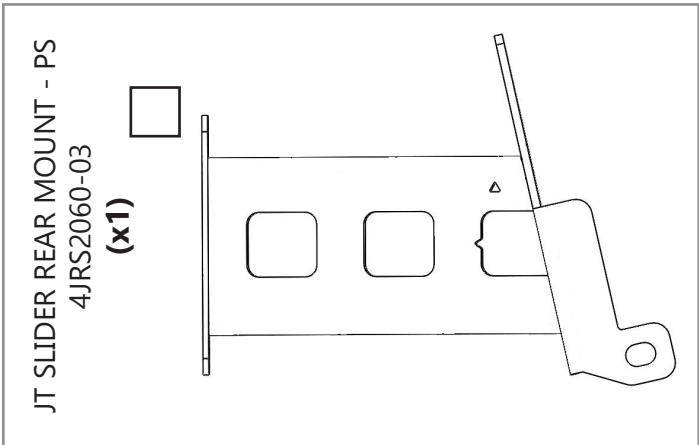
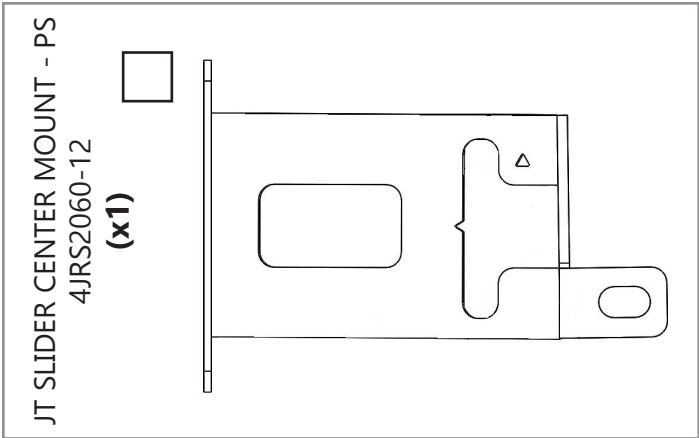
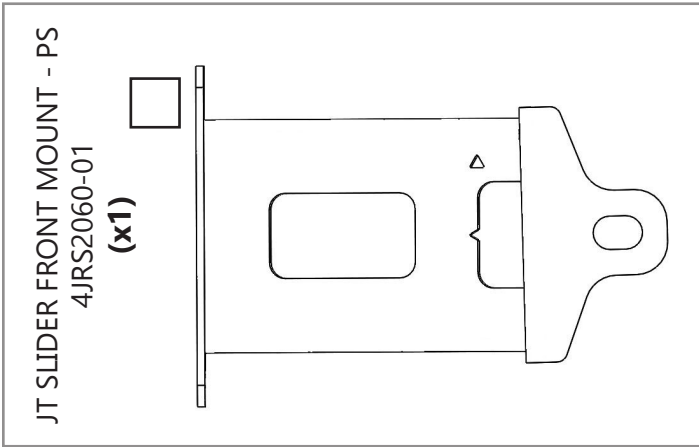
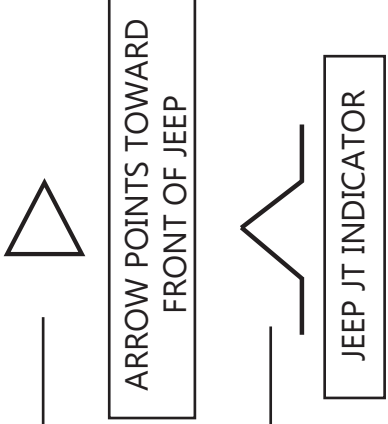
ARROW POINTS TOWARD
FRONT OF JEEP

JEEP JT INDICATOR



JT Jeep
ARMOR LITE SERIES
 JEEP JT 4DR ARMOR LITE
 SLIDERS
 HARDWARE KIT

Packaged by:

On:

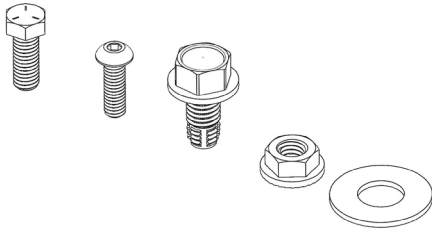

BOLT KIT
 (may vary)

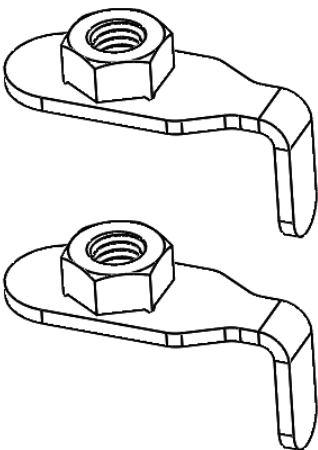

FRONT LOWER FLAG NUT
 4JRS1860-07
(x2)

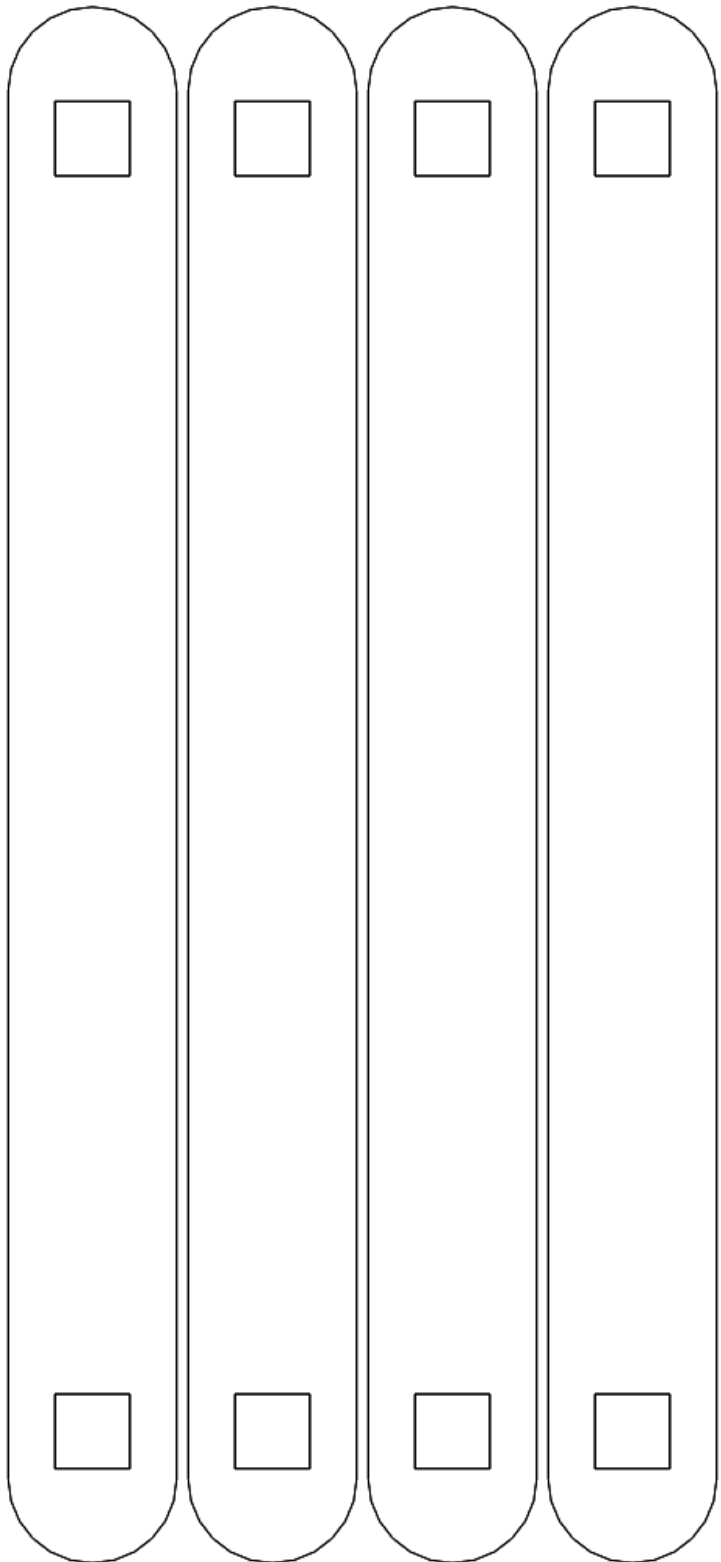

DOUBLE BACKUP PLATE
 2JRS1860-15
(x12)



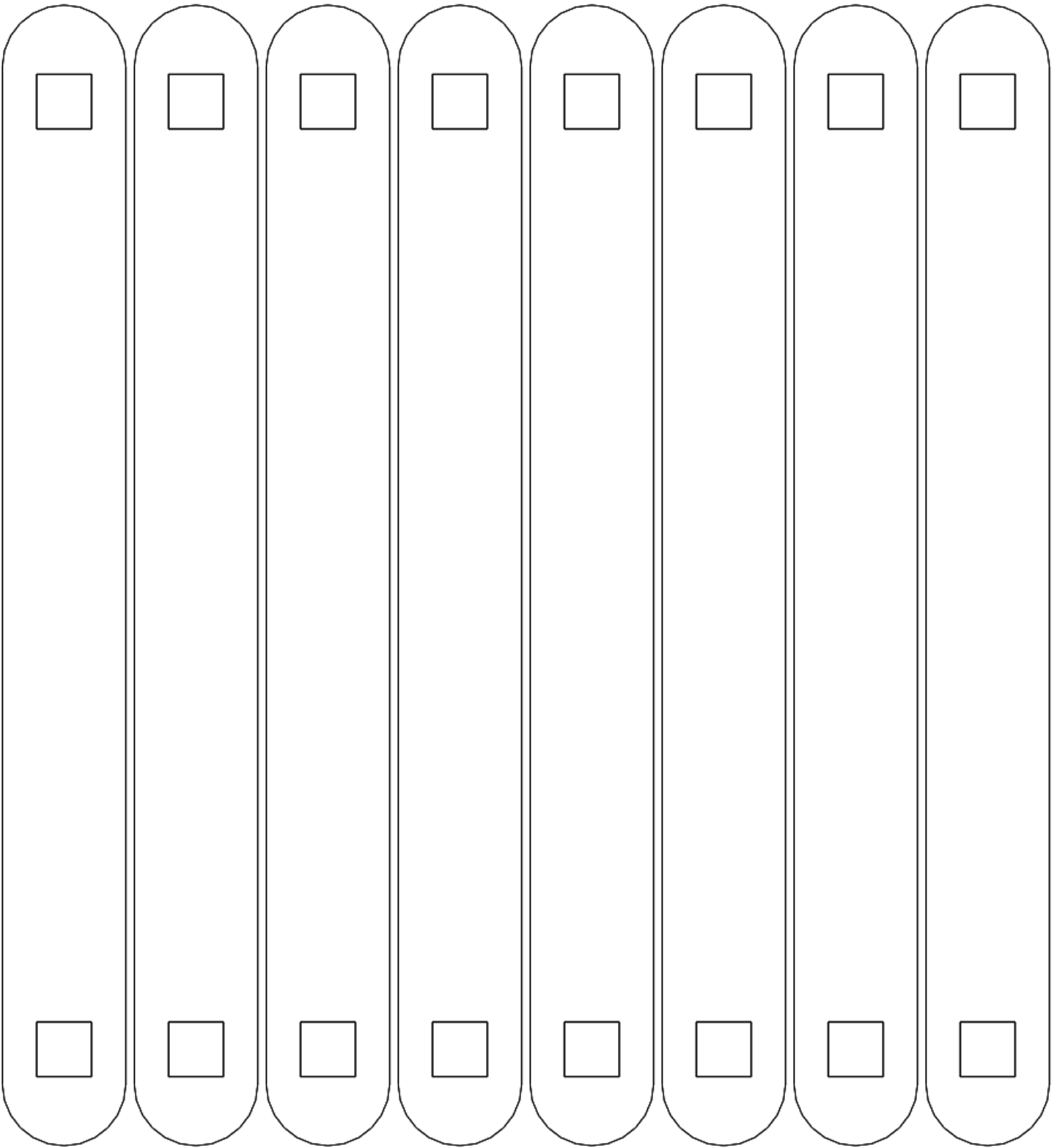

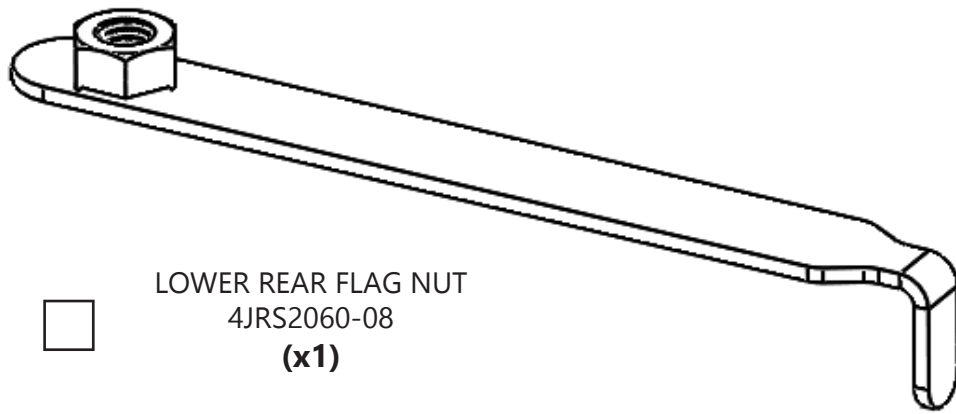

□ LOWER REAR FLAG NUT
4JRS2060-08
(x1)

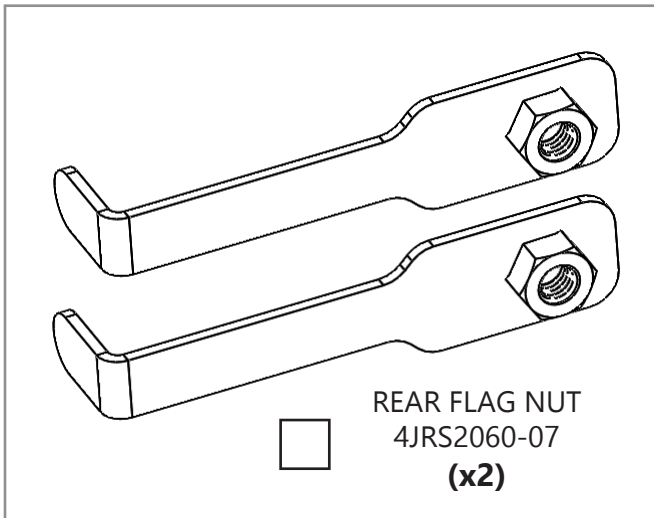

□ REAR FLAG NUT
4JRS2060-07
(x2)

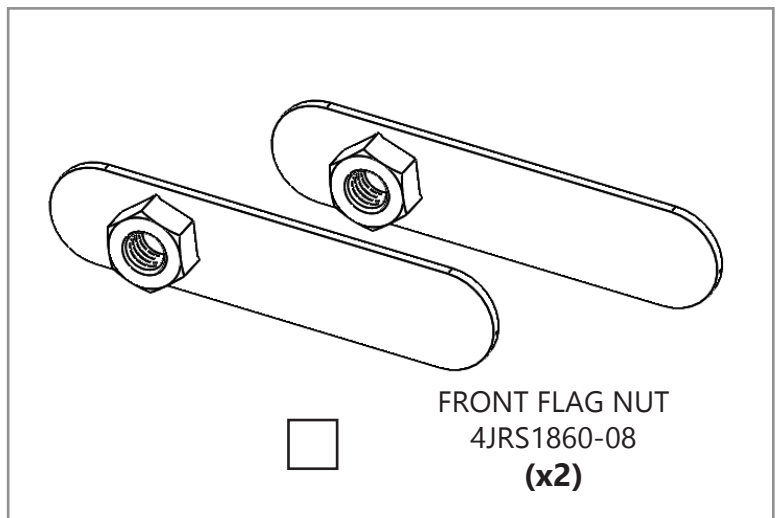

□ FRONT FLAG NUT
4JRS1860-08
(x2)

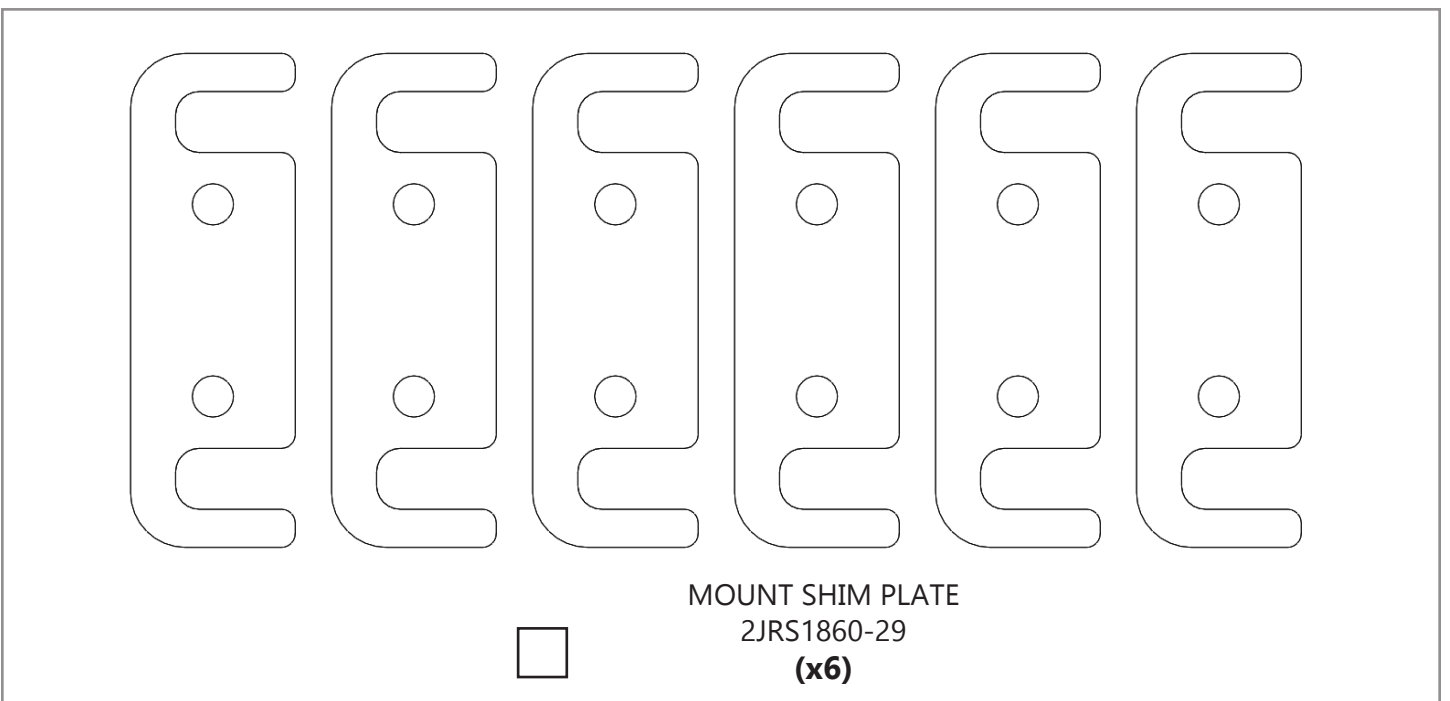

□ MOUNT SHIM PLATE
2JRS1860-29
(x6)



JT Jeep
ARMOR LITE SERIES
JEEP JT 4DR ARMOR LITE
SLIDERS
BOLT KIT

Packaged by:

On:

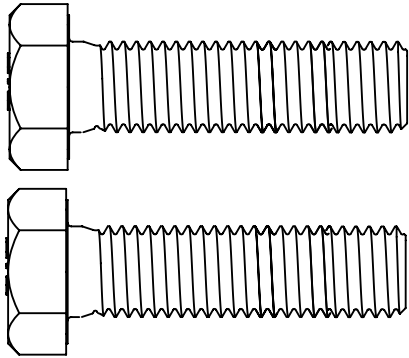

HEX BOLT M12-1.50 X 45MM
(x2)

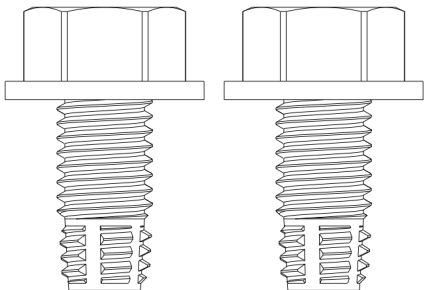

THREAD ROLLER 1/2-13 X 1.00
(x2)

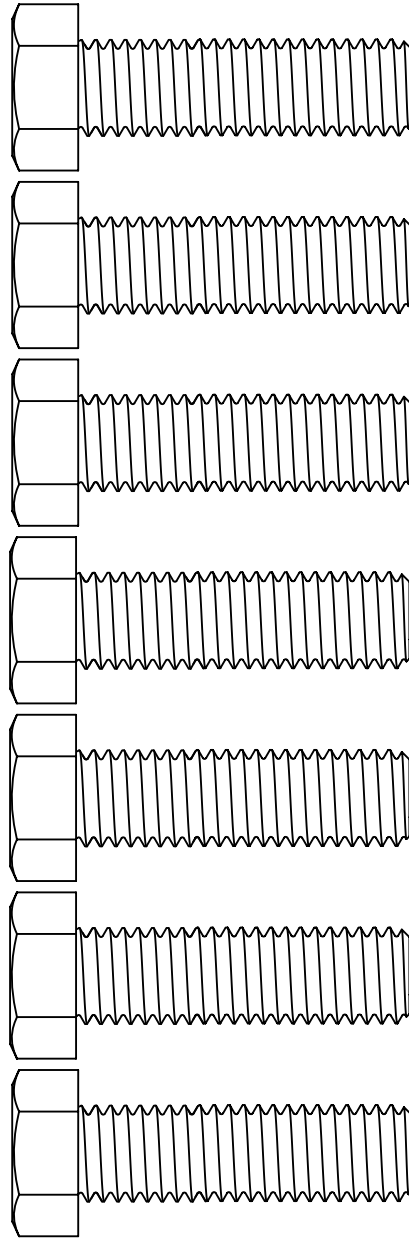

HEX BOLT 1/2-13 X 1.75
(x7)

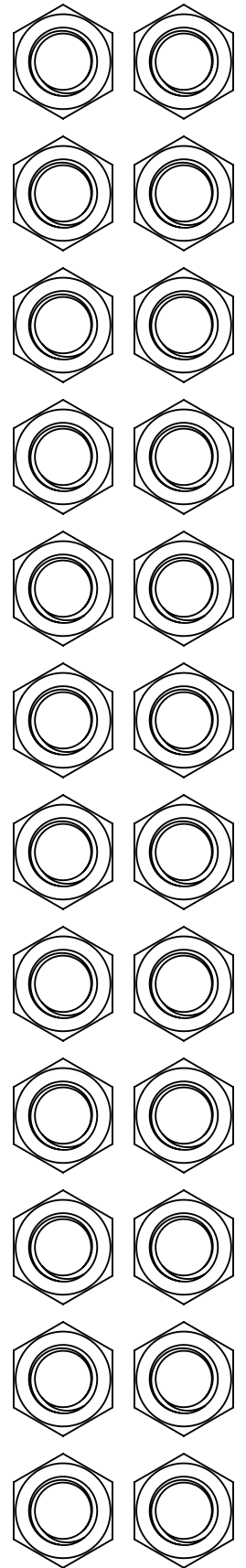

HEX NUT 3/8-16
(x24)

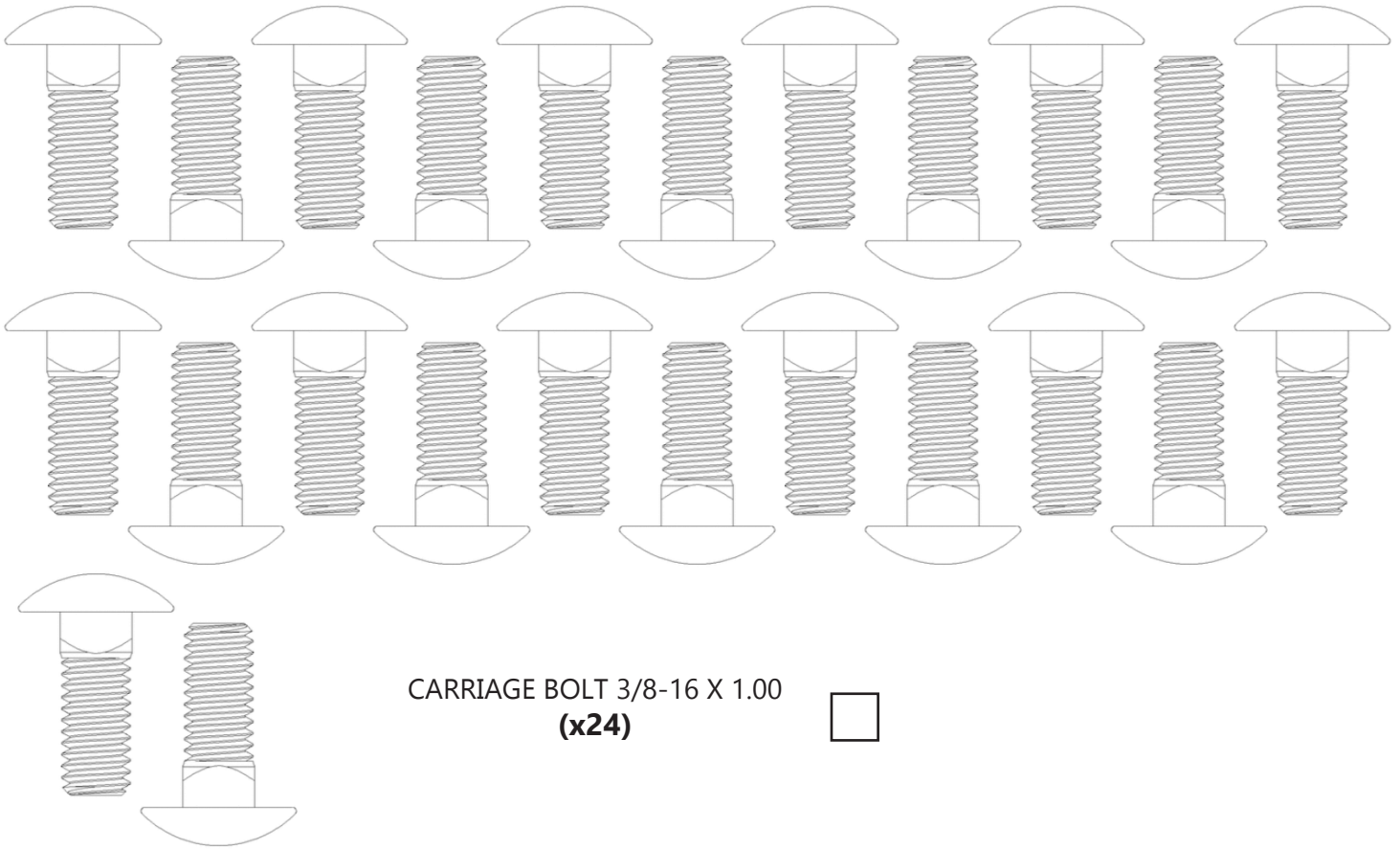

CARRIAGE BOLT 3/8-16 X 1.00
(x24)

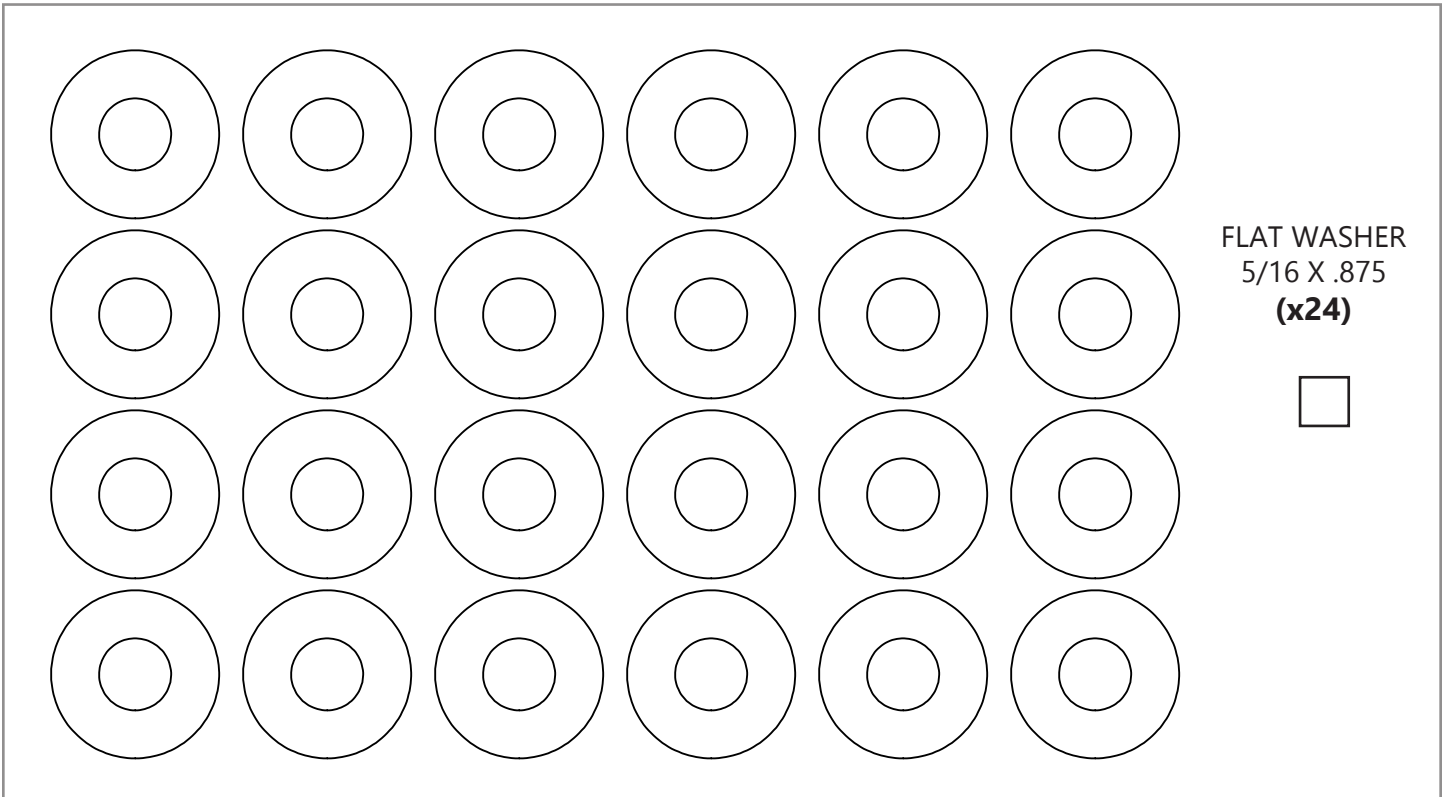

FLAT WASHER
5/16 X .875
(x24)



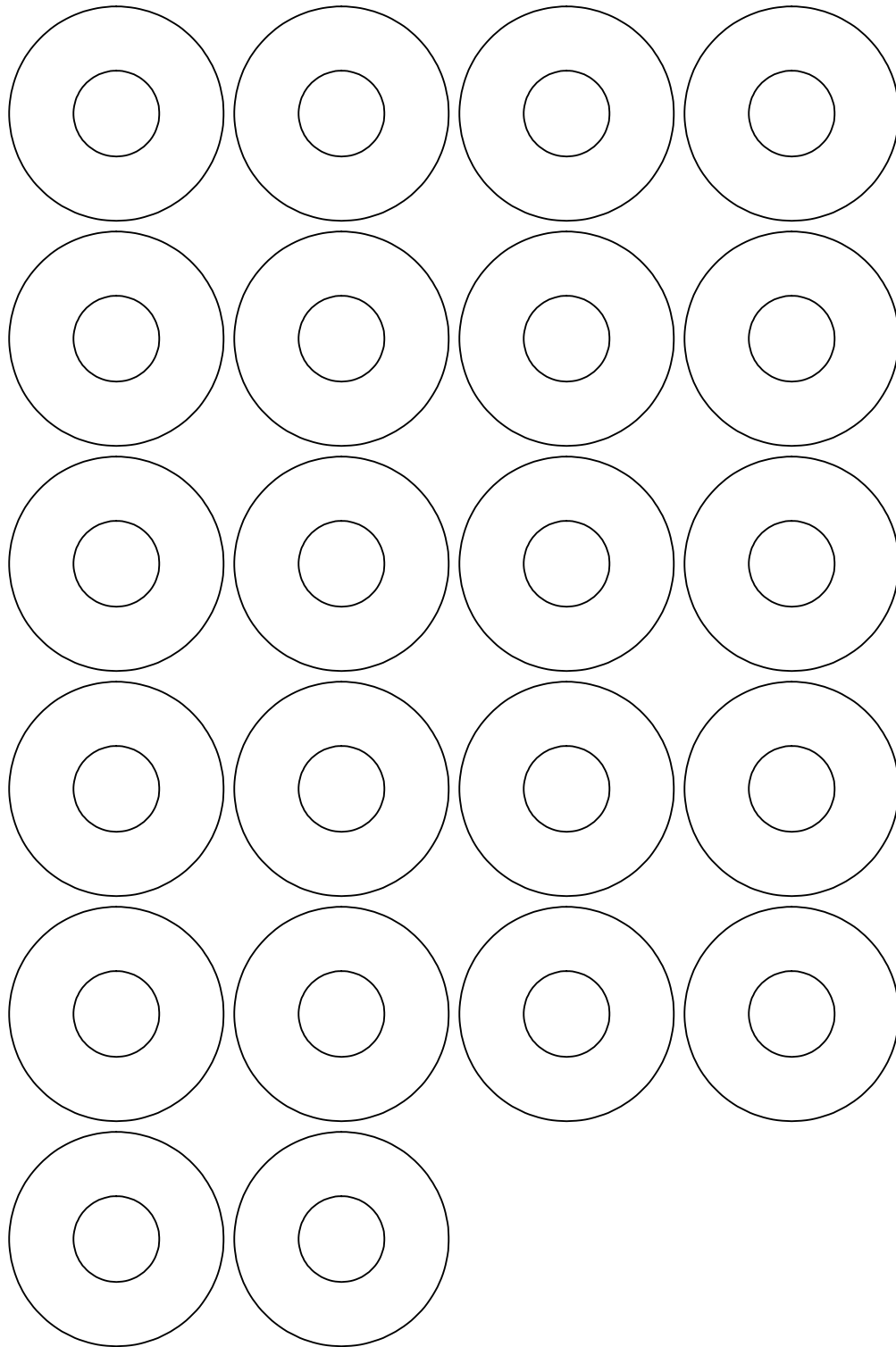

FLAT WASHER
7/16 X 1.25
(x22)