



ARMOR LITE SERIES

JL

**JEEP JL 4DR ARMOR LITE
SLIDERS**



WEB LINK: [http://lodoffroad.com/assets/pdfs/JRS1860 JL 4DR ARMOR LITE SLIDER.pdf](http://lodoffroad.com/assets/pdfs/JRS1860_JL_4DR_ARMOR_LITE_SLIDER.pdf)

***VERIFY YOU HAVE ALL THE COMPONENTS BEFORE STARTING THE INSTALLATION. REFER TO THE
ENGINEERING DRAWINGS AT THE END OF THIS DOCUMENT FOR A COMPLETE PARTS LIST***

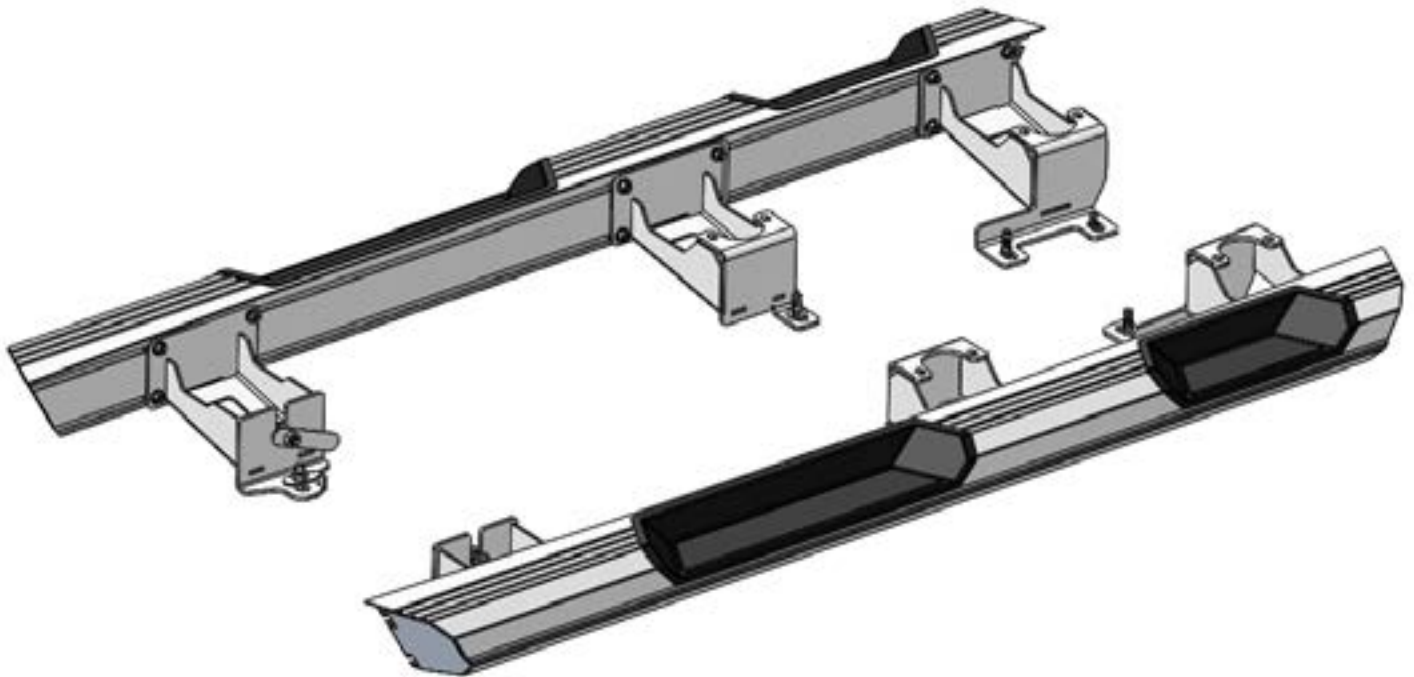

Refer to the Engineering drawing included with this document for the correct hardware required at each step of the installation.

****Some welds and seams way need to be ground flat with a hand grinder****

Install the Rear Mounts as shown using the two body isolator nuts "A" shown below. You may need to loosen the large center bolt slightly if the large washer is in the way, but do not remove it.

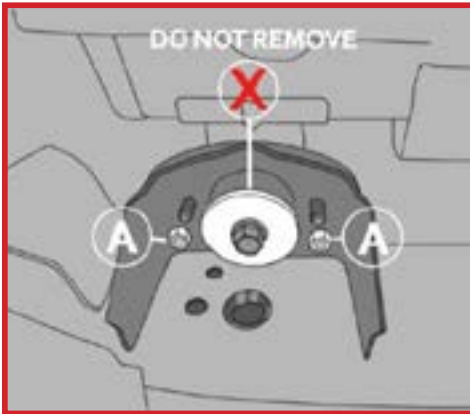

Arrow points to front of vehicle

Optional mounting location

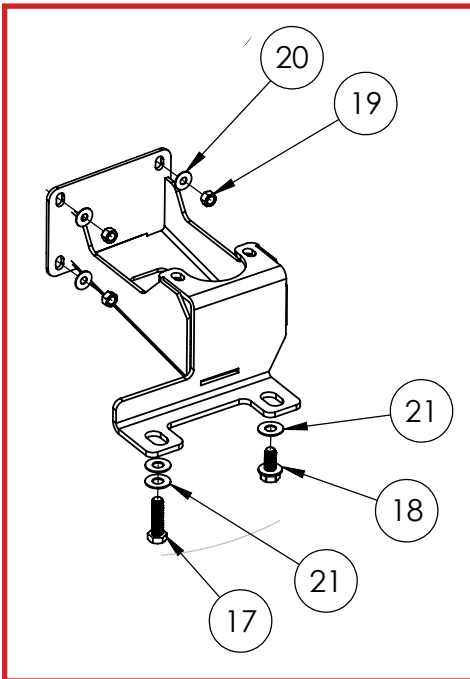

The lower mounting hole is optional (on both passenger and driver side Rear Mounts), but recommended for offroad use. Drill 7/16"Ø hole and insert the self tapping Thread Roller bolts provided. Slowly tighten until fully seated.

Install the Center Mounts as shown using the two body isolator nuts "A" shown below. You may need to loosen the large center bolt slightly if the large washer is in the way, but do not remove it.

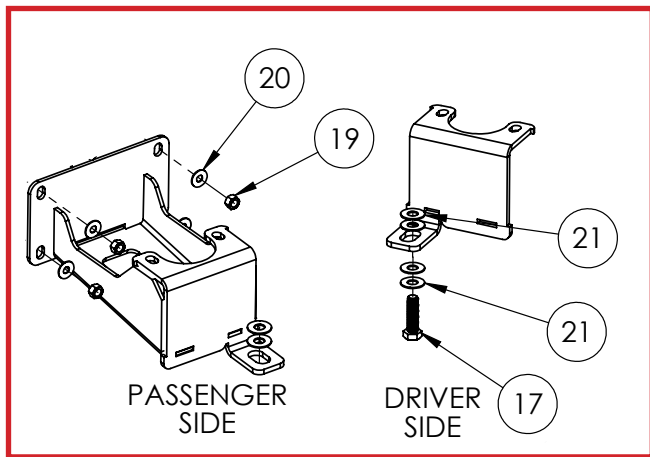
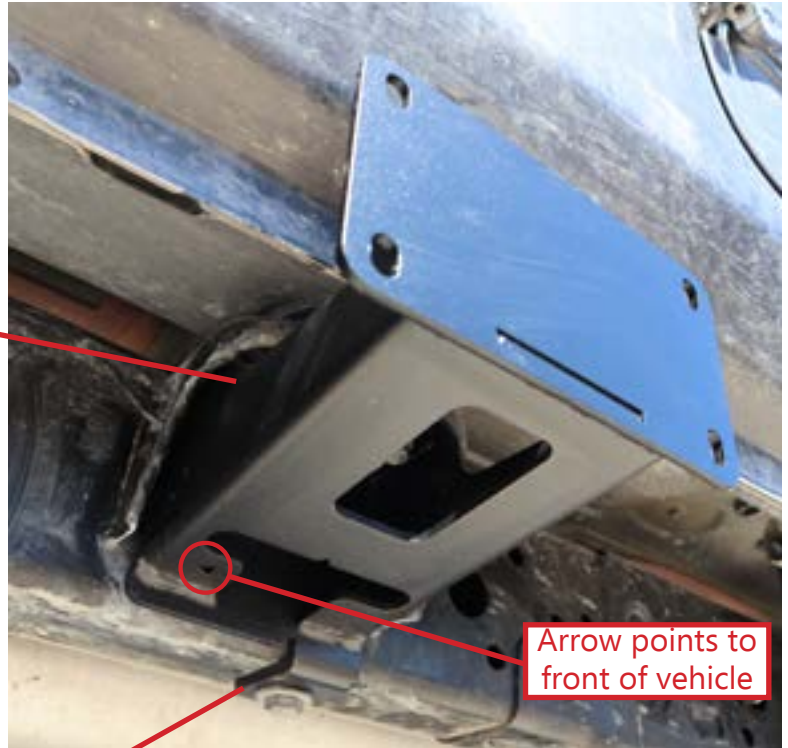

Install the M12 Hex Bolt as shown on the driver side (use the existing bolt on the passenger side). You may double up the washers for extra strength.

Every Jeep frame is slightly different. If you notice a small gap between the frame and the Center Mount lower tab, we include additional spacer washers to fill in this gap. Be sure to tighten all nuts and bolts securely.

Some welds and seams way need to be ground flat with a hand grinder

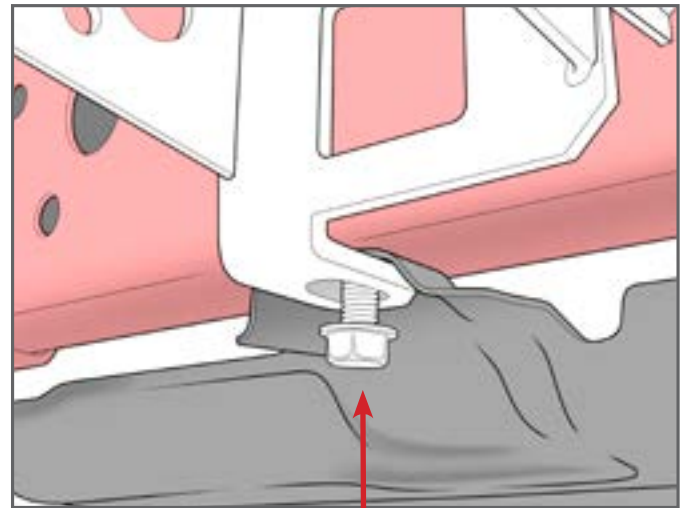

Attach the Armor Lite Slider Mounts over the factor skid plates.

Install the Front Mounts as shown. Install the 1/2" Hex Bolt and Washers onto the Flag Nut and insert into the large slot on the frame rail. Be careful not to drop the Flag Nut into the frame.

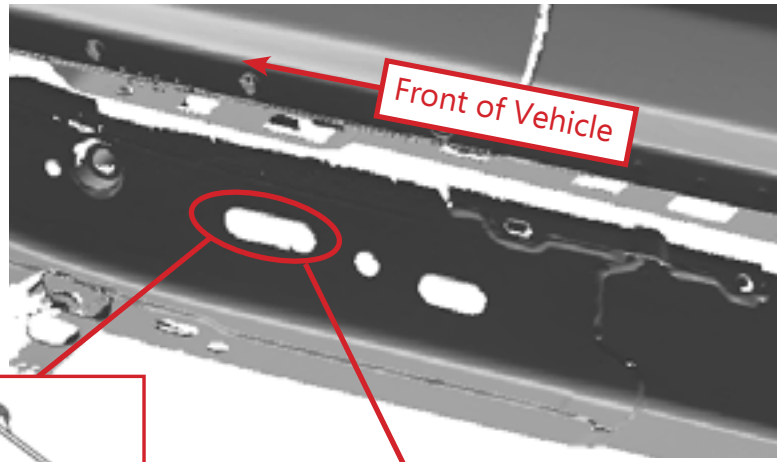
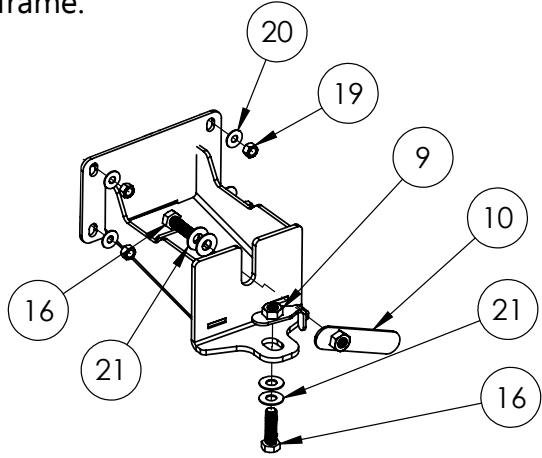

Using your first two fingers, hold the Hex Bolt and Washers. Tighten the Hex Bolt so there is just enough gap for your fingers. Then slide the driver side Front Mount up into position while holding the Hex Bolt and Washers. Once in position tighten the Hex Bolt just enough to hold it in place.

Install the lower Flag Nut into the frame rail and install the 1/2" Hex Bolt and Washers. Slowly tighten both Hex Bolts equally. Use a combination wrench or ratchet with a 3" extension to tighten the Hex Bolt in side of the frame rail.



Hole in frame rail for Flag Nut



****Some welds and seams may need to be ground flat with a hand grinder.****

Install 4 Double Backup Plates with Carriage Bolts as shown into the T-Slots on the back of the Armor Lite Step Assembly. Position these for the Front and Center Mounts.



Install 1 Small Double Backup Plate and 1 Single Backup Plate as shown. Position these for the Rear Mount.



Align the Double Backup Plates as shown, front, center and rear. Line the bolts up with the holes in the Mounts and rotate the Step Assembly into place.



It is helpful to have a friend assist with this step to get all the bolts into the mounting holes at the same time. Once in place, loosely attach with Hex Nuts and Washers

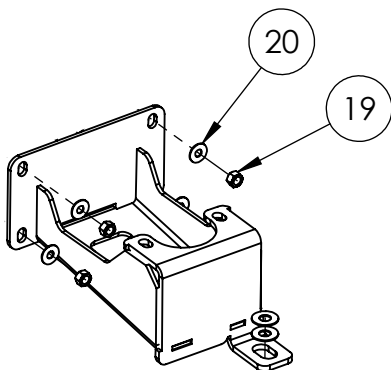
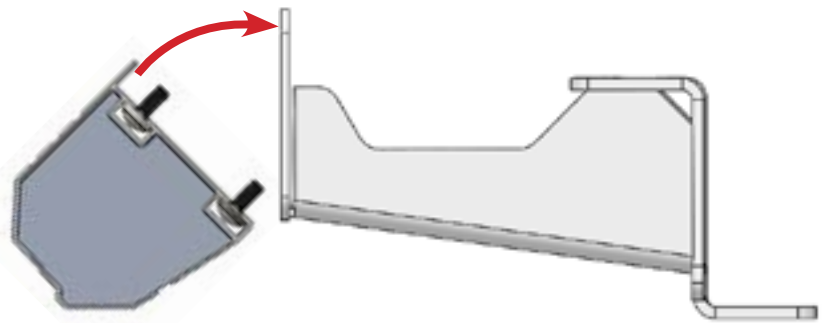



If necessary you can adjust the sliders slightly by rotating it, or moving up/down or forward/backward to get an even gap between back side of your sliders and your Jeep body.

Every Jeep is different and due to the Jeep manufacturing process, you might find that your slider is a little too close to the body of your Jeep. To resolve this we provide Shim Plates to help get the perfect gap. These plates can be installed without completely removing your slider. Simply loosen a few of the mounting bolts and slide the Shim Plate in where needed between the mount and back of the slider body.

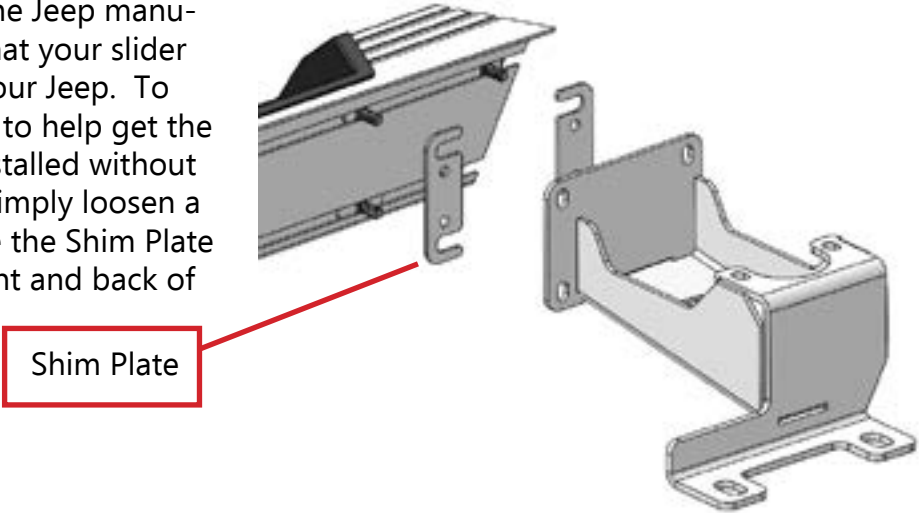

****Maintenance****

- Periodically check and re-tighten all fasteners.
- Periodically check your Armor Lite Sliders for scratches or dings which can happen over time or after heavy use or highway driving. It is important to address these areas as soon as possible to prevent flaking and corrosion or rust from spreading. We recommend using Rustoleum® brand Black Semi-Gloss Protective Enamel (oil based). Remove loose powder coating, sand the area and clean using alcohol. Apply using a foam brush by dabbing to match the powder coat texture.



ITEM NO.	PART NUMBER	DESCRIPTION	QTY.
1	4JRS1860-13	JL ARMOR LITE STEP ASSEMBLY - PS	1
2	4JRS1860-14	JL ARMOR LITE STEP ASSEMBLY - DS	1
3	4JRS1860-04	JL SLIDER FRONT MOUNT DS	1
4	4JRS1860-01	JL SLIDER FRONT MOUNT PS	1
5	4JRS1860-05	JL SLIDER CENTER MOUNT DS	1
6	4JRS1860-02	JL SLIDER CENTER MOUNT PS	1
7	4JRS1860-06	JL SLIDER REAR MOUNT DS	1
8	4JRS1860-03	JL SLIDER REAR MOUNT PS	1
9	4JRS1860-07	FRONT LOWER FLAG NUT	2
10	4JRS1860-08	FRONT FLAG NUT	2
11	2JRS1860-15	DOUBLE BACKUP PLATE	8
12	2JRS1860-23	DOUBLE BACKUP PLATE SMALL	2
13	2JRS1860-24	SINGLE BACKUP PLATE	2
14	2JRS1860-29	MOUNT SHIM PLATE	6

HARDWARE

ITEM NO.	PART NUMBER	DESCRIPTION	QTY.
15	CB381616ZPGR5	CARRIAGE BOLT 3/8-16 X 1.00 ZINC PLATE GR5	22
16	HB501328ZPGR5	HEX BOLT 1/2-13 X 1.75 HEX BOLT ZINC PLATE GR5	4
17	HB12150M45ZPCL88	HEX BOLT M12-1.50 x 45mm ZINC PLATE CL8.8	3
18	TR501316ZP	THREAD ROLLER 1/2-13 X 1.00 HEX ZINC PLATE	2
19	HN3816ZPGR5	HEX NUT 3/8-16 ZINC PLATE GR5	22
20	FW3114ZP	FLAT WASHER Ø5/16" X .875" ZINC PLATE	22
21	FW4318ZP	FLAT WASHER Ø7/16 X 1.25" ZINC PLATED	20

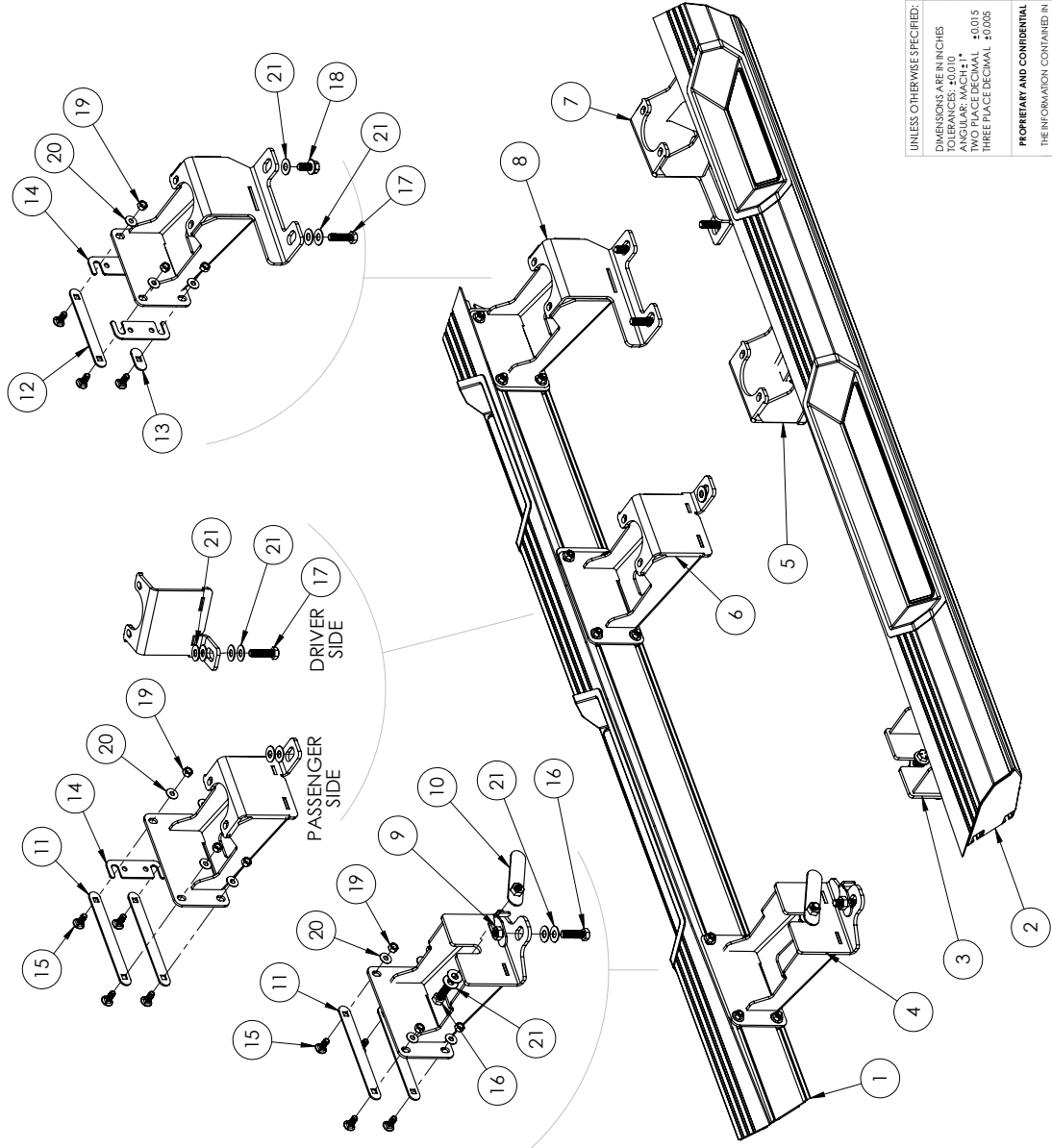

NOTES:

- JRS1860 = BARE ALUMINUM/STEEL
- JRS1861 = BLACK POWDER COAT

NAME	DATE	LOD LLC.
MCH	5/11/2020	
DESCRIPTION: JEEP JL 4DR ARMOR LITE SLIDER		
DRAWN	CHECKED	
ENG. APPR.	MFG APPR.	
MATERIAL: N/A		
FINISH: BLACK POWDER COAT		
ECCO:		
THE INFORMATION CONTAINED IN THIS DRAWING IS THE PROPERTY OF LOD LLC. ANY REPRODUCTION IN PART OR AS A WHOLE WITHOUT THE WRITTEN PERMISSION OF LOD LLC IS PROHIBITED.		
DWG. NO.	JRS1860	REV
	JRS1861	A
SCALE:	1:8	SHEET SIZE: B
		SHEET 1 OF 1



JL Jeep
ARMOR LITE SERIES
 JEEP JL 4DR ARMOR LITE
 SLIDERS
 SHIPPING SHEET - BOX 1

Packaged by:

On:

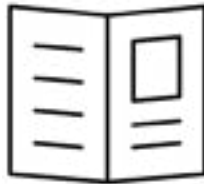

Instruction
Booklet

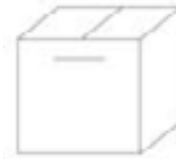

Hardware Kit

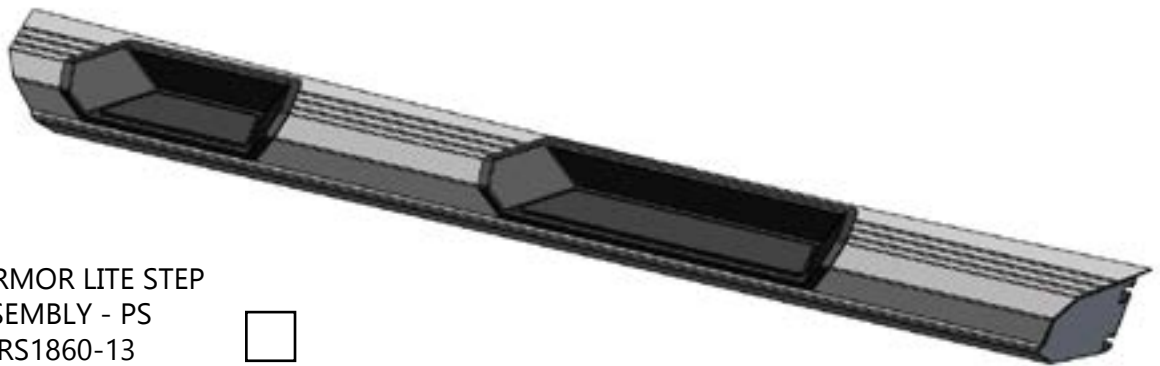

JL/JK ARMOR LITE STEP
 ASSEMBLY - PS
 4JRS1860-13
(x1)



JL/JK ARMOR LITE STEP
 ASSEMBLY - DS
 4JRS1860-14
(x1)





JL Jeep
DESTROYER/ARMOR LITE
 JEEP JL 4DR SLIDERS
 SHIPPING SHEET - BOX 2

Packaged by: _____

On: _____

JL SLIDER FRONT MOUNT - PS
 4JRS1860-01
(x1)

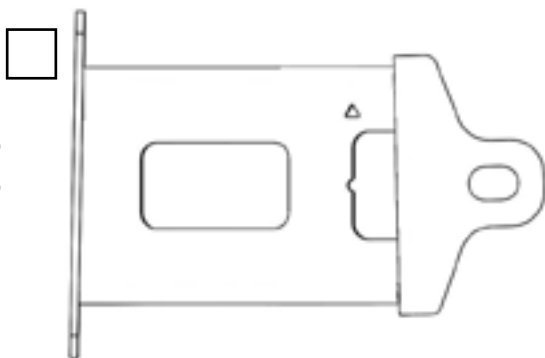

JL SLIDER CENTER MOUNT - PS
 4JRS1860-02
(x1)

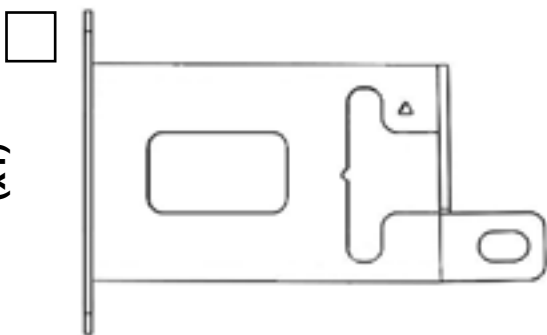

JL SLIDER REAR MOUNT - PS
 4JRS1860-03
(x1)

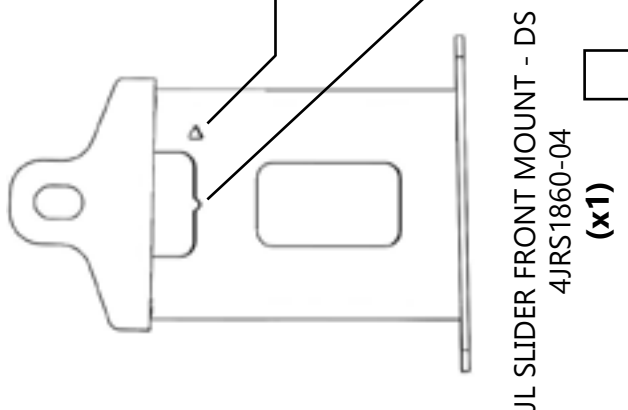
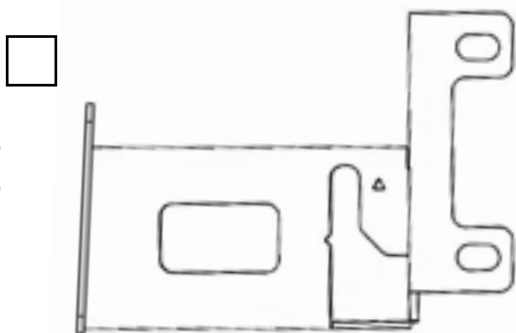

JL SLIDER FRONT MOUNT - DS
 4JRS1860-04
(x1)

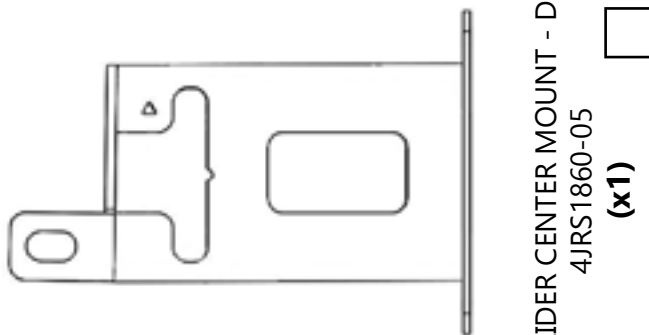

JL SLIDER CENTER MOUNT - DS
 4JRS1860-05
(x1)

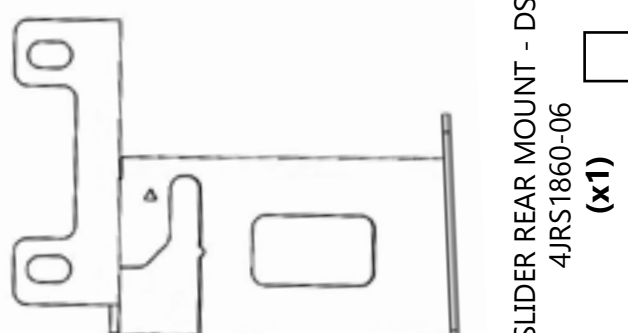

JL SLIDER REAR MOUNT - DS
 4JRS1860-06
(x1)



ARROW POINTS TOWARD
 FRONT OF JEEP



JEEP JL INDICATOR



JL Jeep
ARMOR LITE SERIES
 JEEP JL 4DR ARMOR LITE
 SLIDERS
 HARDWARE KIT

Packaged by:

On:

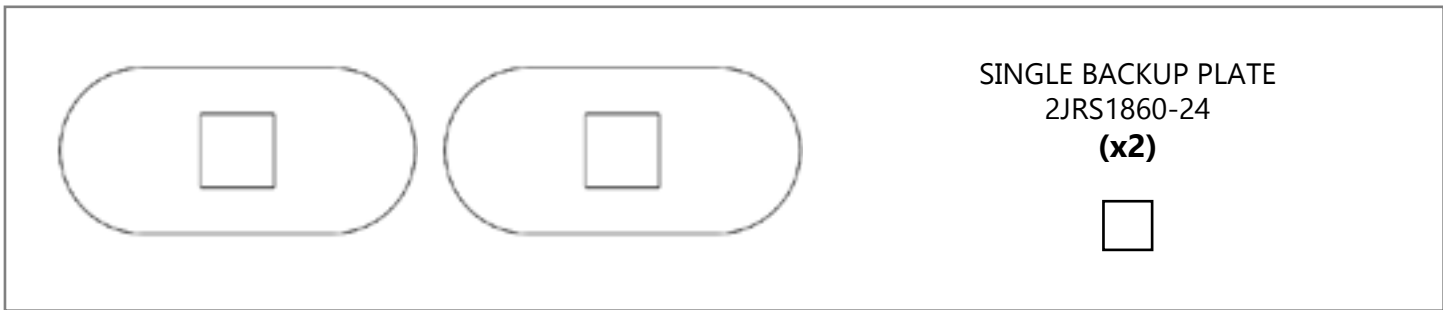
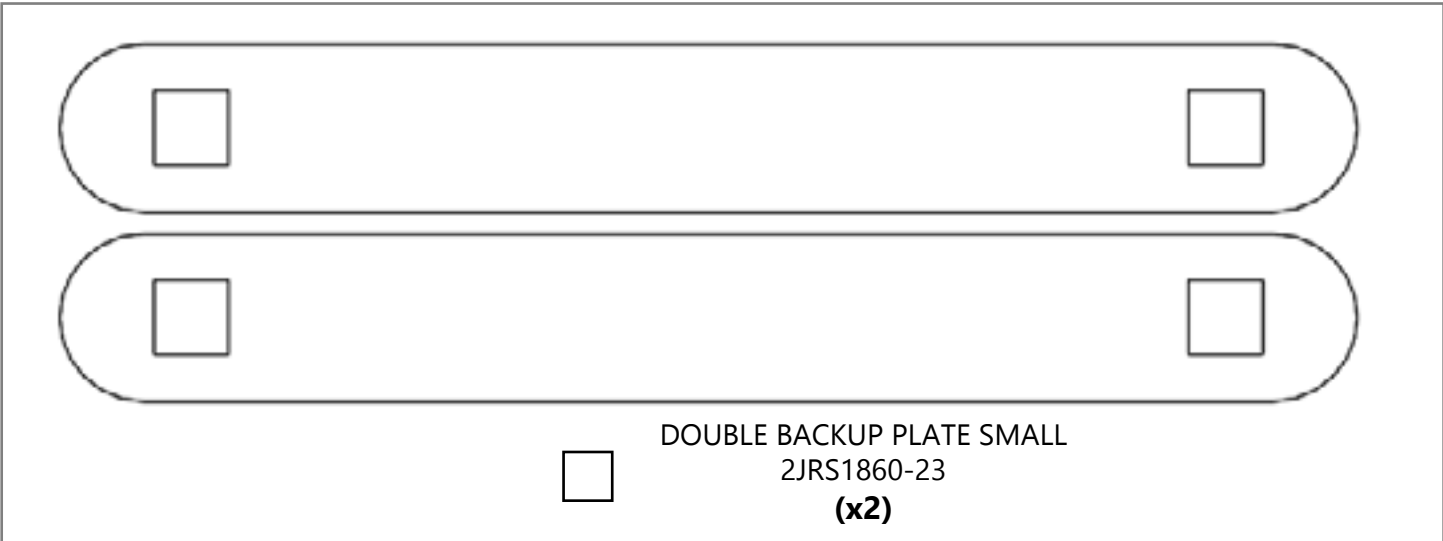
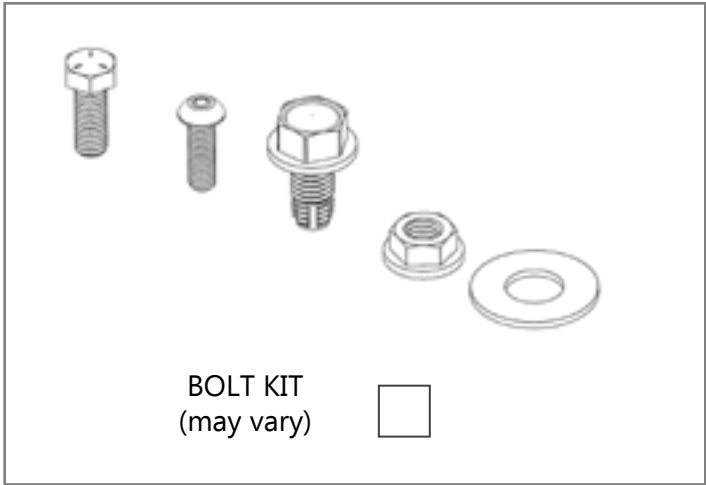

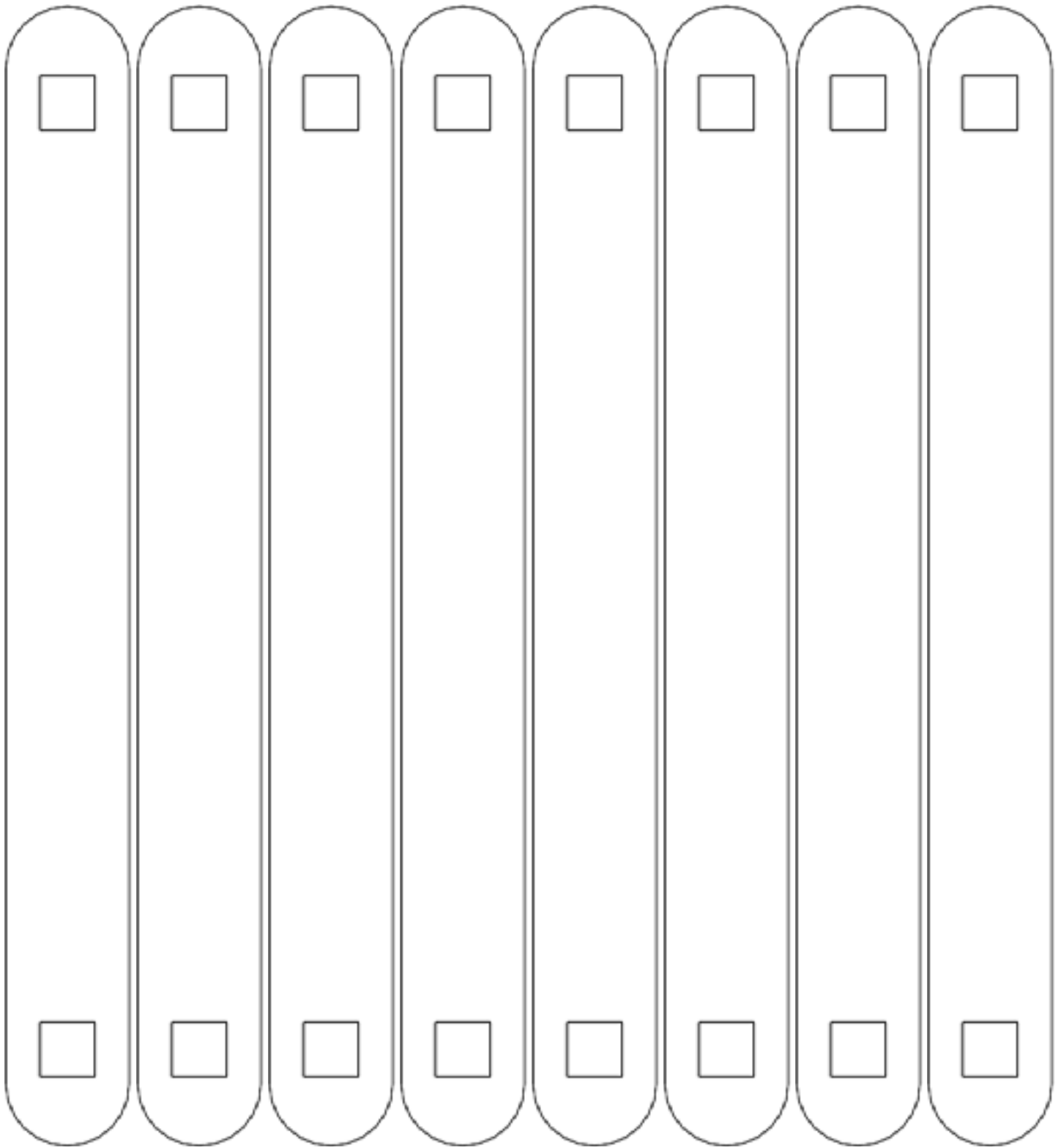

DOUBLE BACKUP PLATE
2JRS1860-15
(x8)



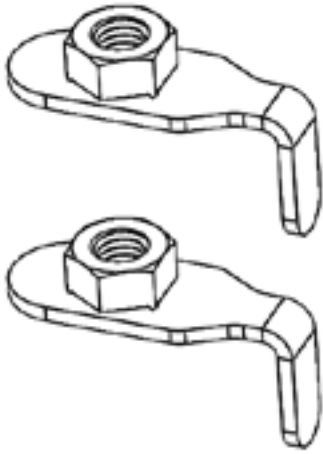

FRONT LOWER FLAG NUT
4JRS1860-07
(x2)

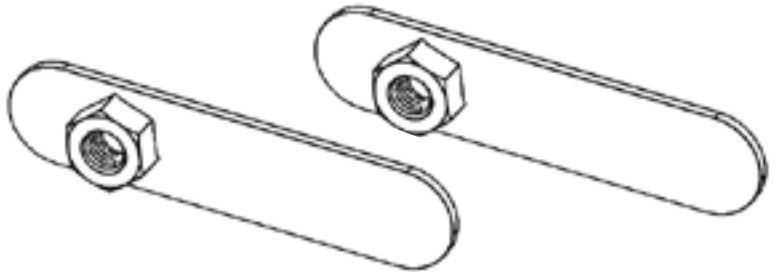

FRONT FLAG NUT
4JRS1860-08
(x2)

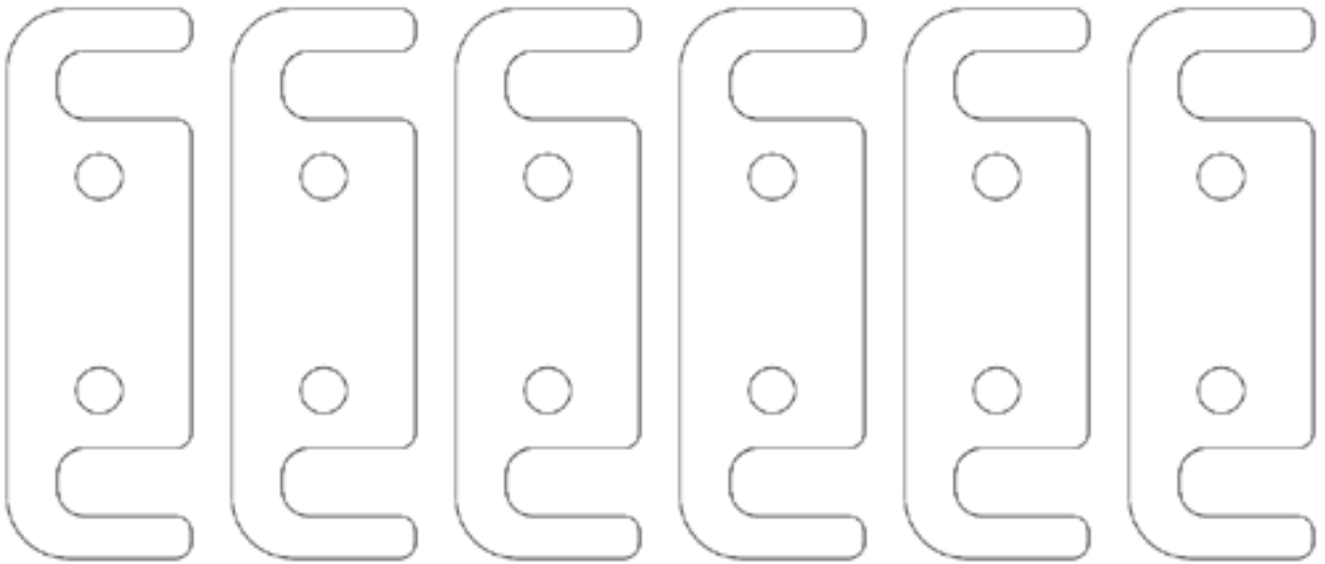

MOUNT SHIM PLATE
2JRS1860-29
(x6)





JL Jeep
ARMOR LITE SERIES
 JEEP JL 4DR ARMOR LITE
 SLIDERS
 BOLT KIT

Packaged by:

 On:

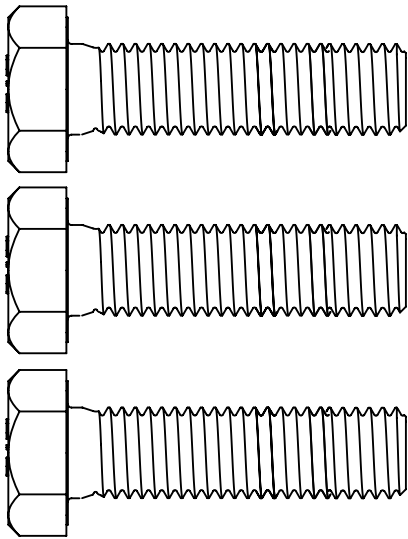

HEX BOLT M12-1.50 X 45MM
(x3)

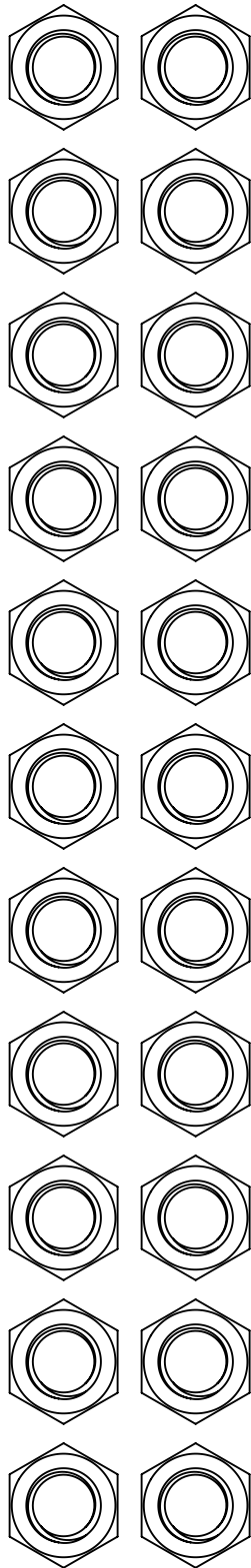

HEX NUT 3/8-16
(x22)

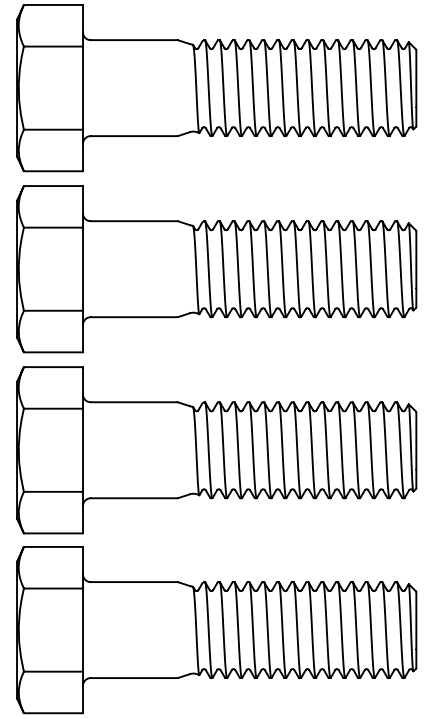

HEX BOLT 1/2-13 X 1.75
(x4)

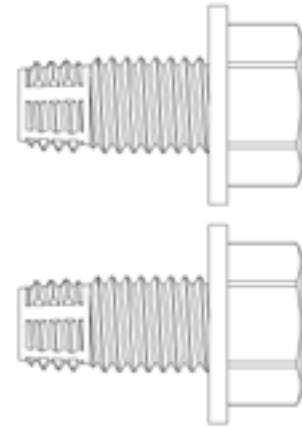

THREAD ROLLER 1/2-13 X 1.00
(x2)



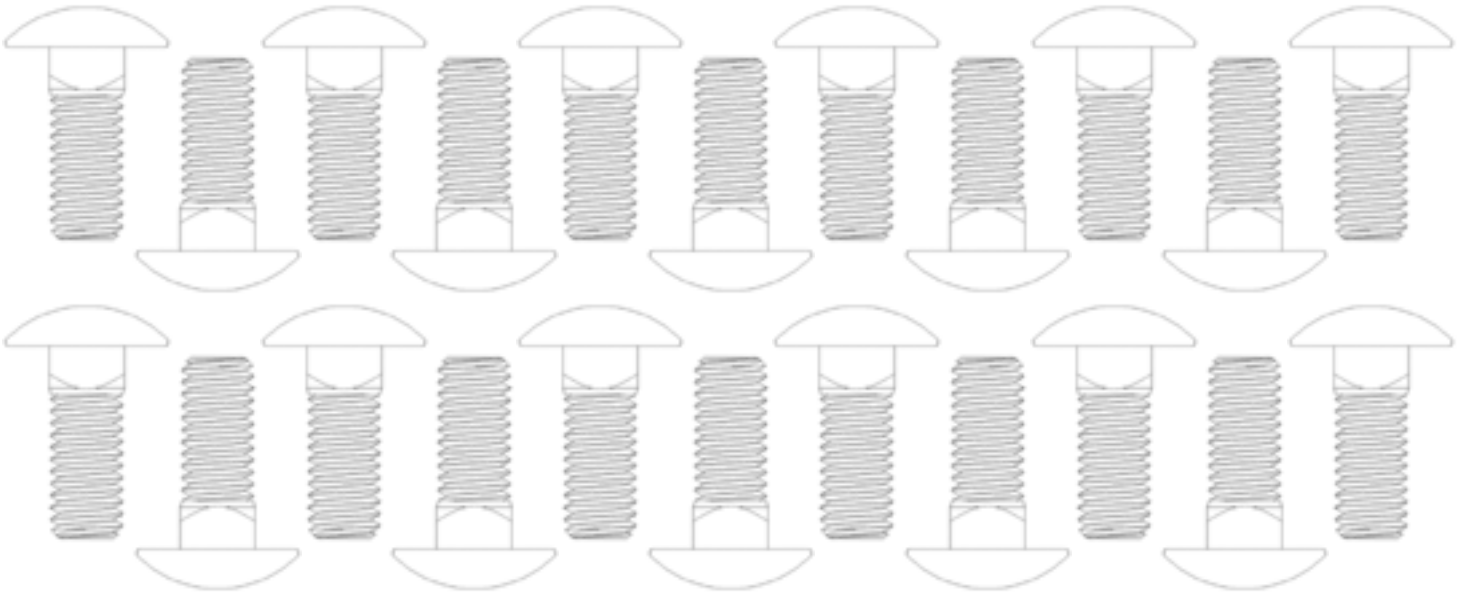

CARRIAGE BOLT 3/8-16 X 1.00
(x22)

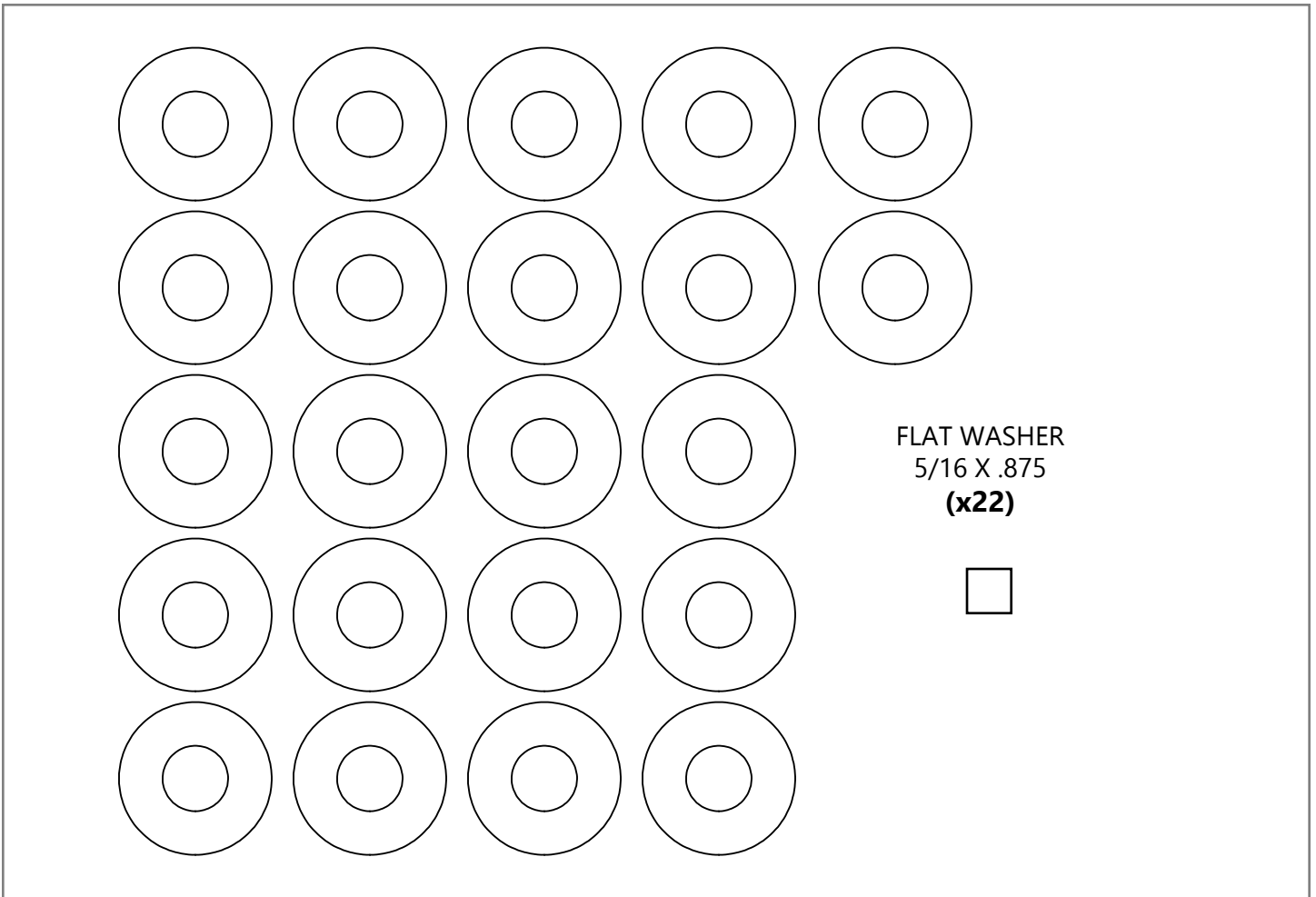

FLAT WASHER
5/16 X .875
(x22)



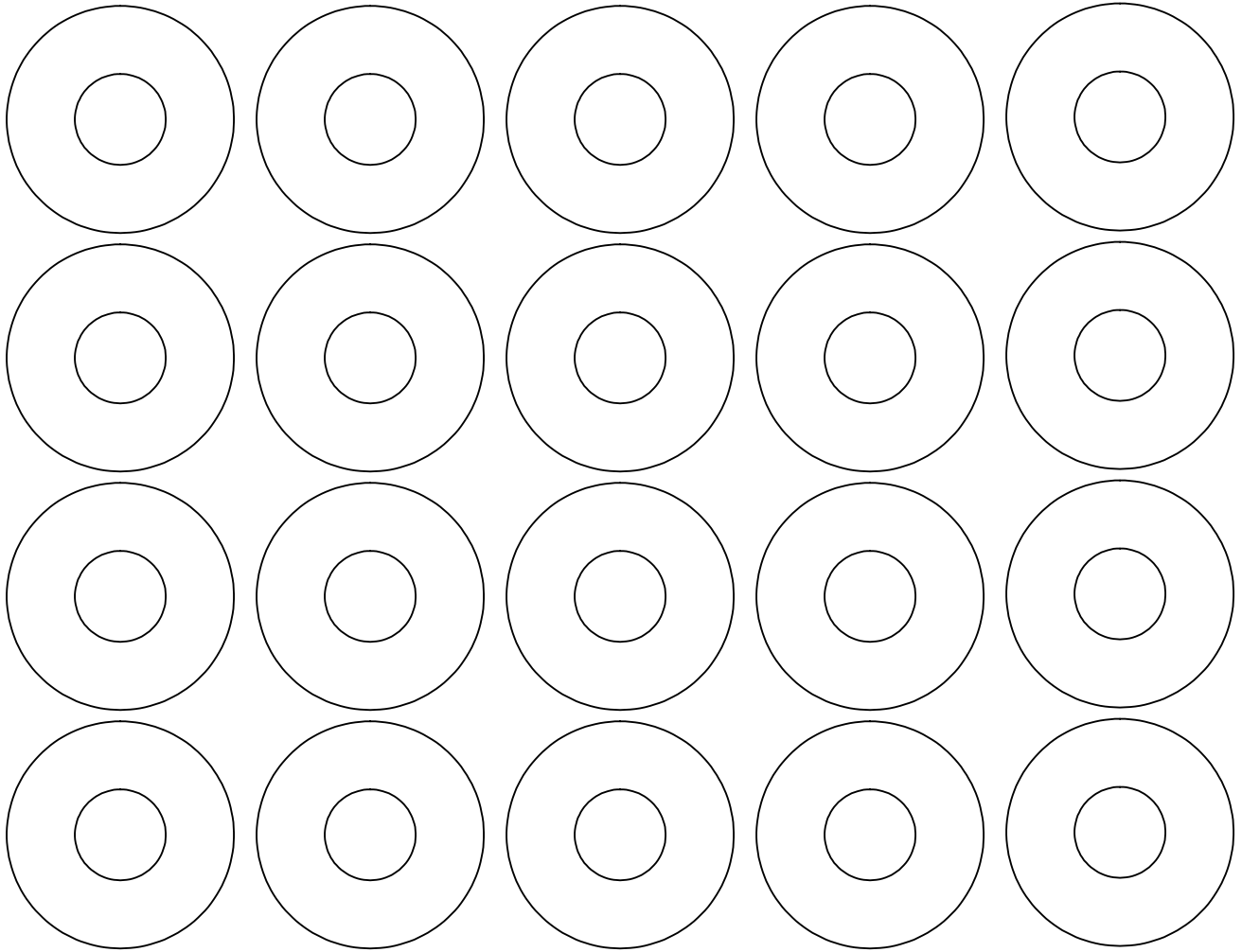

FLAT WASHER
7/16 X 1.25
(x20)

