



**DESTROYER SERIES**  
**JK JEEP**  
**REAR BUMPER**

**INSTALLATION**  
**INSTRUCTIONS**

**STEP 1:**

GATHER YOUR TOOLS  
AND LAY OUT YOUR PARTS...

**Tools Required:**

- 16mm socket
- 5/32" Allen wrench
- 3/4" socket
- 1/4" socket
- ratchet
- ratchet Extension
- 3/4" wrench
- tape measure
- floor jack or car jack
- drill with 1/2" drill bit



**\*PLEASE READ THROUGH  
THE INSTRUCTIONS BEFORE  
BEGINNING ANY PART OF THE  
INSTALLATION PROCESS\***

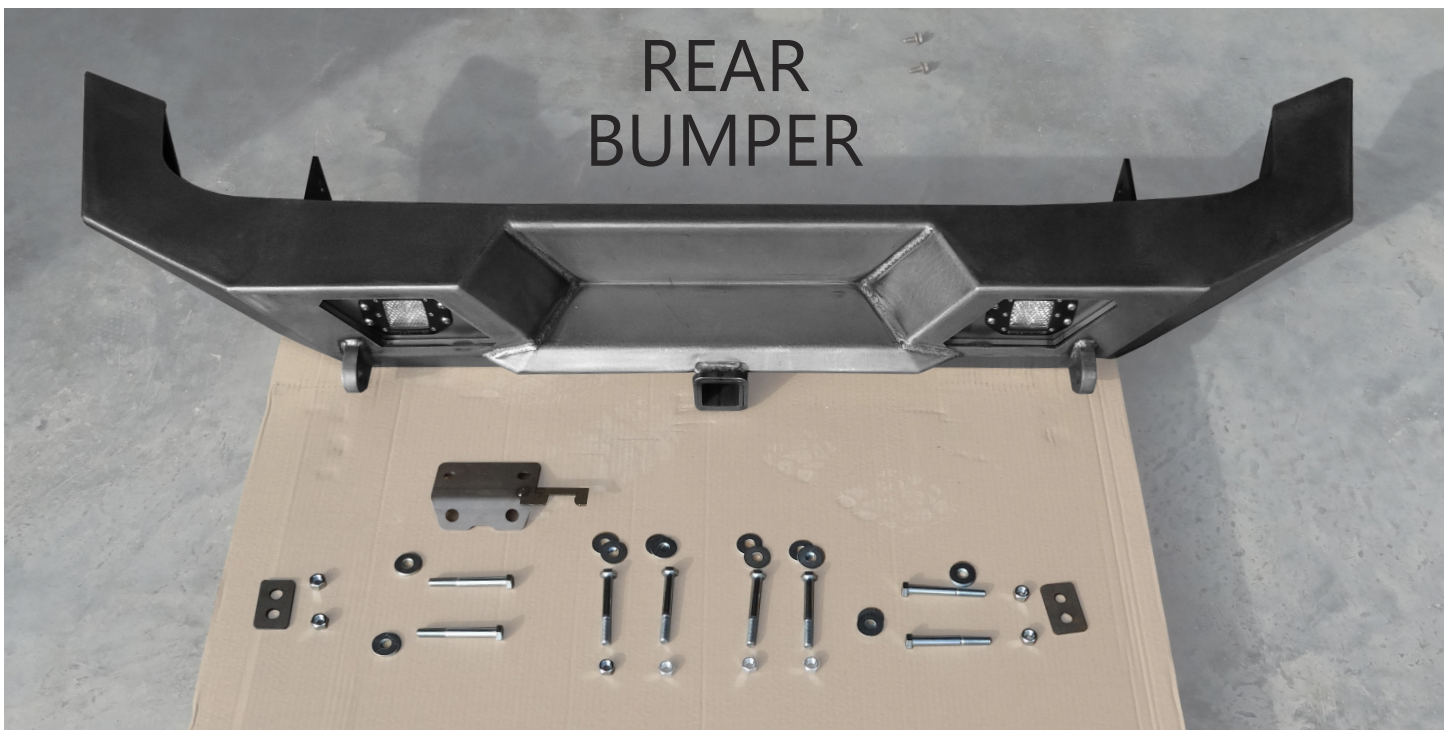

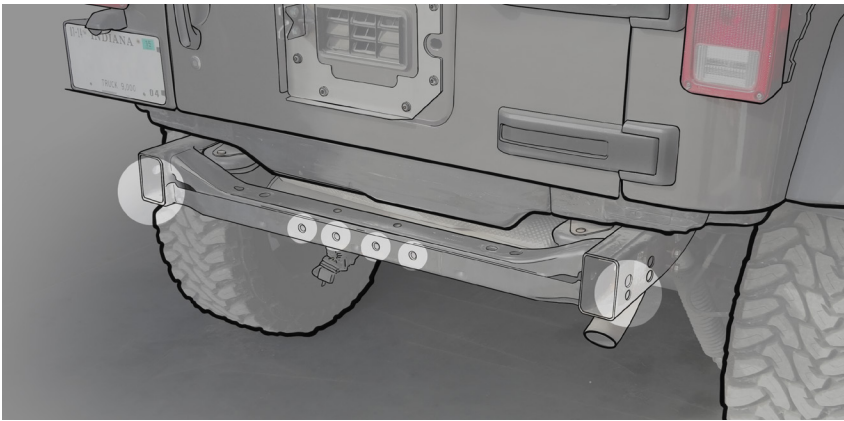

## **STEP 2 :**

Before beginning the installation, there will be 6 locations that require drilling through the cross members, two in the middle and one on each side.

USE A 1/2" DRILL BIT FOR THESE.

## **STEP 3 :**

Each side of the frame will have a hole (shown here) that will need to be marked and drilled with a 5/8" drill bit.

This hole can be drilled with the bumper on the vehicle.

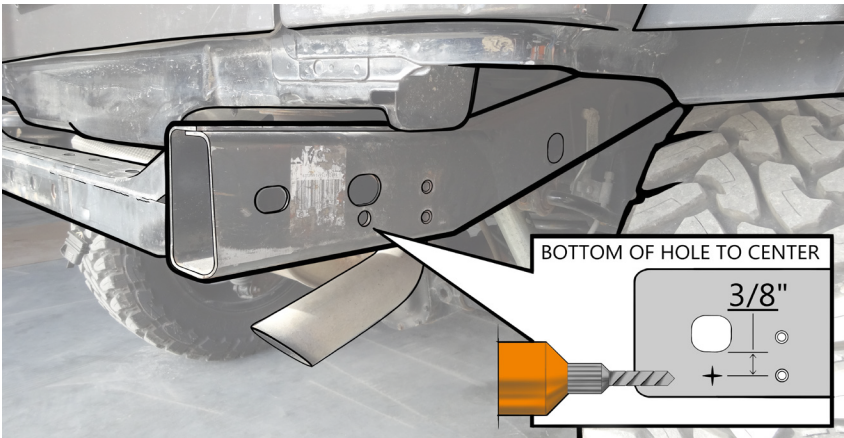

## **STEP 4 :**

Install light bezels using (2) 1/4" Button Head screws.



## **STEP 5 :**

Carefully pick up the bumper and slowly center it, then move towards the Jeep.

Take care to avoid damaging the body with the bumper corners.



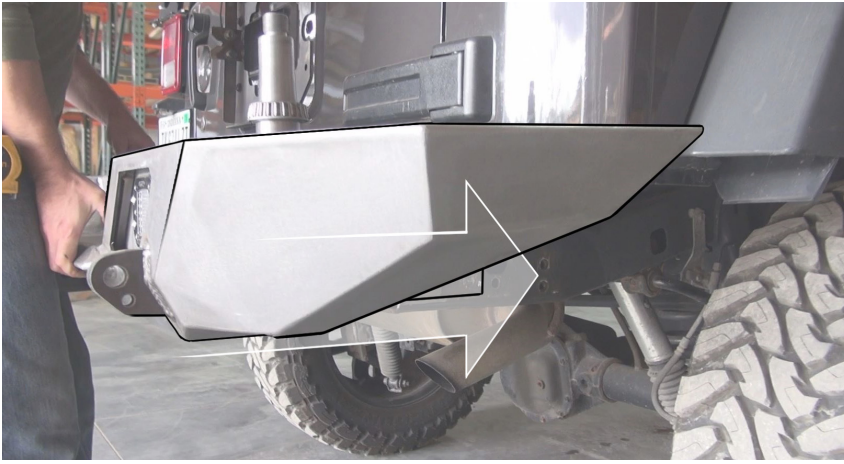

## **STEP 6 :**

Slide the bumper forward onto the frame once the body of the bumper is aligned with the body of the vehicle.



## **STEP 7 :**

Do not let go of the bumper, as it may fall unsupported. While keeping pressure on the bumper, check that the two stock holes (circled) are lining up with the slotted holes in the bumper



## **STEP 8 :**

Insert the two stock frame bolts, do not tighten them all the way.



## **STEP 9 :**

You may now let go of the bumper, the stock bolts will prevent it from falling off.



## **STEP 10 :**

Insert the 4" long bolts into the opening. The bottom hole should have been drilled by this point to provide a space for the bottom 4" bolt.



## **STEP 11 :**

After inserting the bolts, attach the frame backing plate onto the studs, then attach the nuts and washers.



## **STEP 12 :**

Attach the trailer plug to the provided safety chain plate.



## **STEP 13 :**

Locate the two horizontal bolts and align with the holes on the safety chain plate.

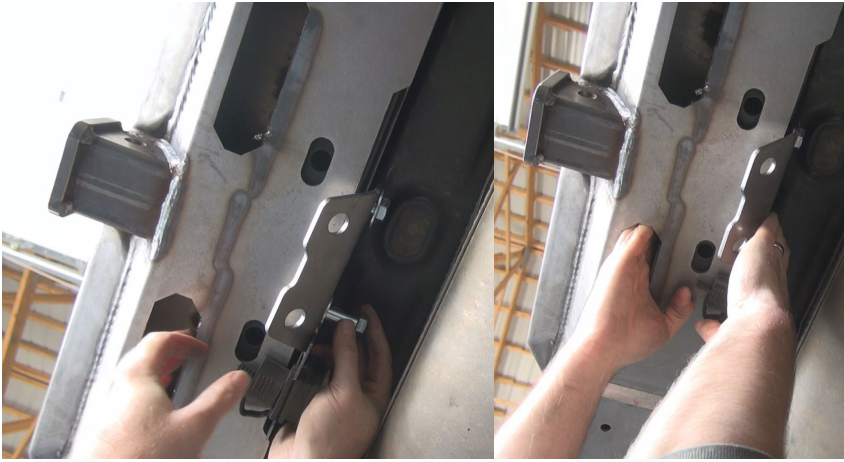

## **STEP 14 :**

Insert the bolts, and loosely thread on the nuts and bolts using the access hole cutouts.



## **STEP 15 :**

At this point, we will be leveling\* the bumper.

\*Having a level bumper is crucial to the proper functioning of the carrier.\*



## **STEP 16 :**

Measure the gap between the bumper and Jeep body on both sides, the measurements should be equal.



## **STEP 17 :**

Tighten the stock bolts, one at a time on each side, one side at a time.



## **STEP 18 :**

As you go back and forth tightening the bolts, keep checking your gap measurements to make sure the bumper has not shifted.



## **STEP 19 :**

After tightening one bolt on the passenger/driver side, check your measurements then repeat in the corresponding bolt on the opposite side of the car.

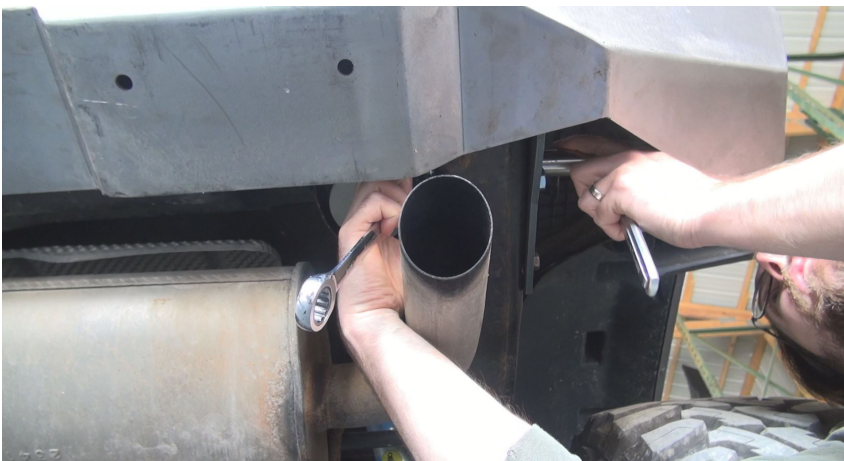

## **STEP 20 :**

Use a wrench to reach and keep the nuts in place while you tighten the bolts.



## **STEP 21 :**

Using the access holes and the 3/4 wrenches, tighten the bolts that hold the safety chain plate to the crossmember.

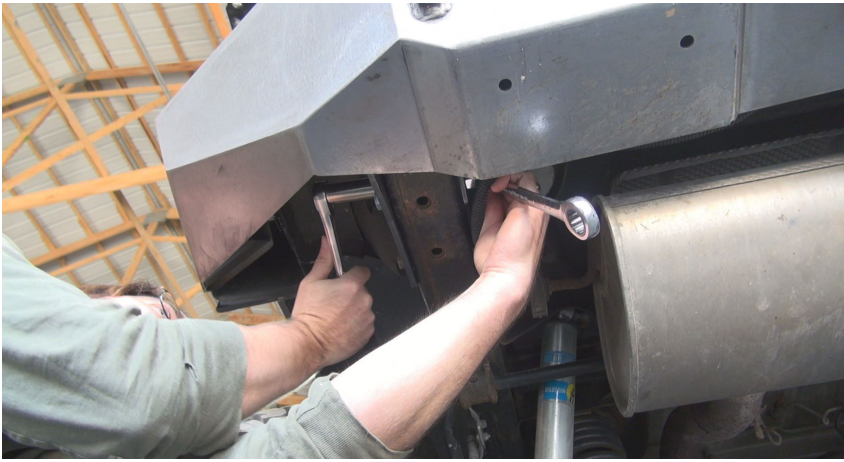

## **STEP 22 :**

Check that all of the bolts securing the bumper to the Jeep are tight now.

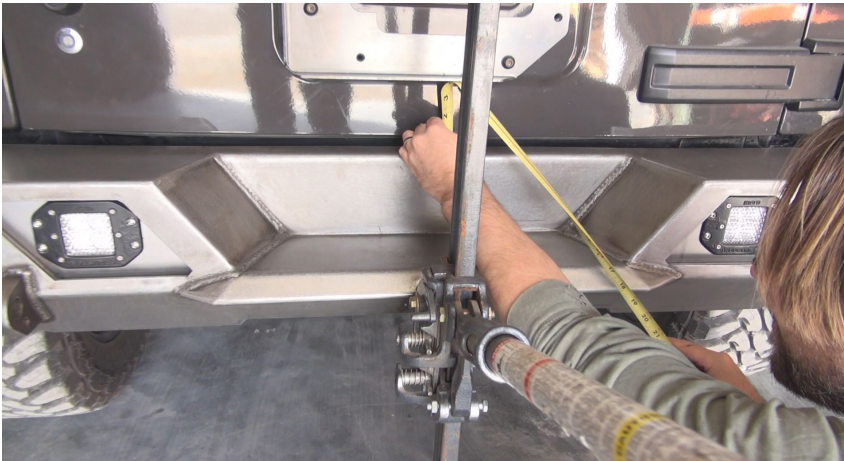

## **STEP 23 :**

Measure the middle and corner gaps between the Jeep body and the bumper to make sure it has not changed.

ITEM NO.	PART NUMBER	DESCRIPTION	QTY.
1	4JRB1001-02	DESTROYER SHORTY REAR BUMPER WELDMENT	1

**HARDWARE KIT**

ITEM NO.	PART NUMBER	DESCRIPTION	QTY.
2	LOD logo	Logo Plate	1
3	4JTC1001-10	SAFETY CHAIN PLATE	1
4	2JTC1001-S1	FRAME BACKUP PLATE	2
5	FW5022ZF	FLAT WASHER Ø1/2" X 1.375" ZINC PLATE	16
6	HN5013ZFGRS	HEX NUT 1/2-13 ZINC PLATE GRS	8
7	HB501364ZFGRS	HEX BOLT 1/2-13 X 4.00 HEX BOLT ZINC PLATE GRS	6
8	HB501372ZFGRS	HEX BOLT 1/2-13 X 4.50 HEX BOLT ZINC PLATE GRS	2
9	BHSCS252008SS	BHSCS 1/4-20 X 0.50 STAINLESS STEEL	4

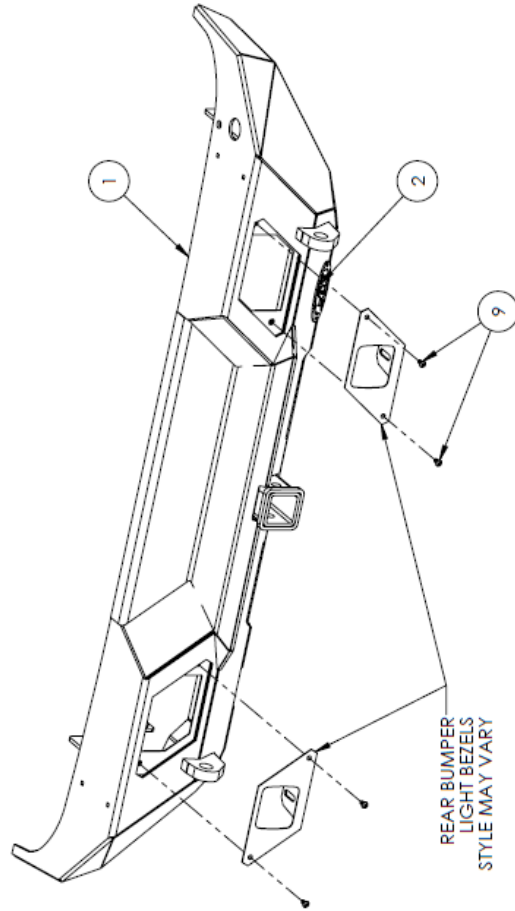
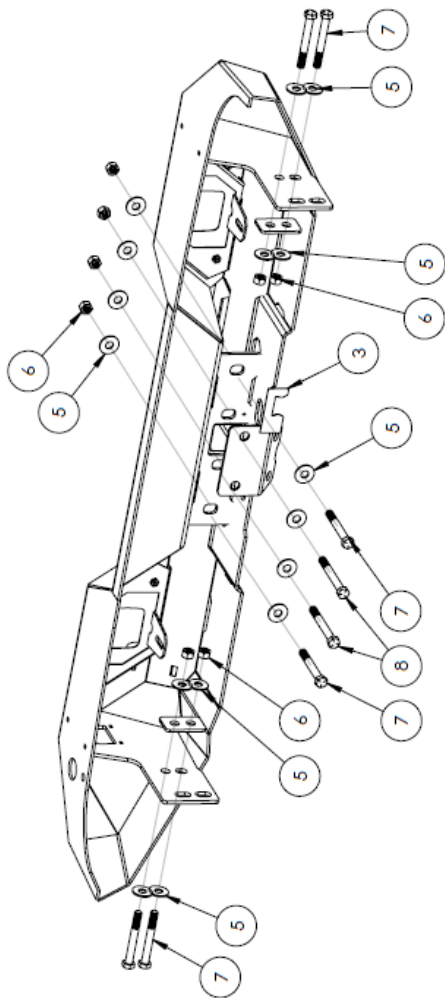

**NOTES:**

- JRB0700 = BARE STEEL OPTION
- JRB0701 = BLACK POWDER COAT OPTION

UNLESS OTHERWISE SPECIFIED:	NAME	DATE
DRAWN	MCH	12/9/2018
CHECKED		
ENG APPR.		
MFG APPR.		
MATERIAL:		
FINISH:		

LOD LLC.

DESCRIPTION:  
DESTROYER SHORTY REAR BUMPER ONLY

DWG. NO. JRB0700  
JRB0701

SCALE: 1:8 SHEET SIZE: B

REV C

SHEET 1 OF 1





**JK Jeep**  
**DESTROYER SERIES**  
 Rear Bumper  
 SHIPPING SHEET

Packaged by:

\_\_\_\_\_

On:

\_\_\_\_\_

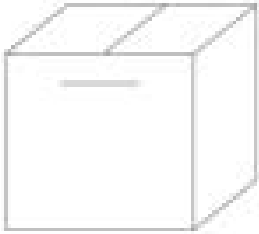





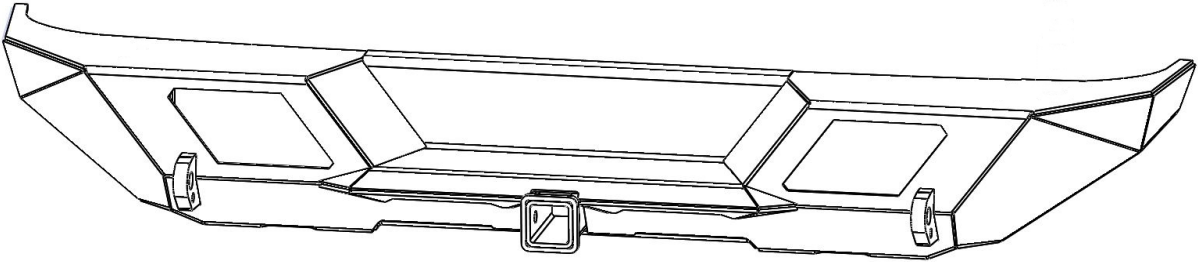

Hardware Kit  
(contents may vary)

Destroyer  
Rear Bumper

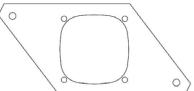

**Destroyer Light Bezels**  
(STYLE MAY VARY, ONLY ONE SET INCLUDED)

						
Blank / No light JLB1851	Universal Flush Mount Cube JLB1821	Rigid Pro-Series Dually JLB1841	Baja Designs Squadron Flush Mount JLB1863	Baja Designs Squadron JLB1865	Baja Designs Squadron Round JLB1867	LoD Radiant Pro LED Surface Mount JLB1869
<input data-bbox="185 1774 241 1827" type="checkbox"/>	<input data-bbox="378 1774 435 1827" type="checkbox"/>	<input data-bbox="574 1774 631 1827" type="checkbox"/>	<input data-bbox="771 1774 828 1827" type="checkbox"/>	<input data-bbox="967 1774 1024 1827" type="checkbox"/>	<input data-bbox="1164 1774 1221 1827" type="checkbox"/>	<input data-bbox="1360 1774 1417 1827" type="checkbox"/>



**JK Jeep  
DESTROYER SERIES**

Rear Bumper  
Hardware Kit

Packaged by:

\_\_\_\_\_

On:

\_\_\_\_\_

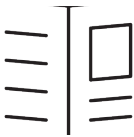

Instruction  
Booklet

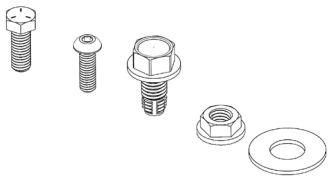

**BOLTS**  
(may vary)

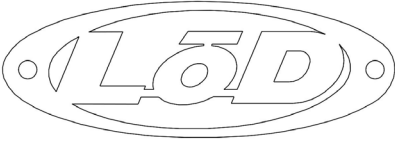

**LoD Logo  
Plate (x1)**  
(packaged separate if  
bumper is bare steel)

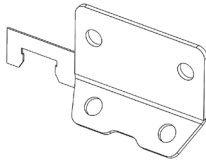

**JK Safety Chain  
Plate**

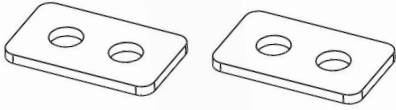

**Frame Backing Plate (x2)**



**JK Jeep  
DESTROYER SERIES**

Rear Bumper

Bolt Kit

Packaged by:

\_\_\_\_\_

On:

\_\_\_\_\_

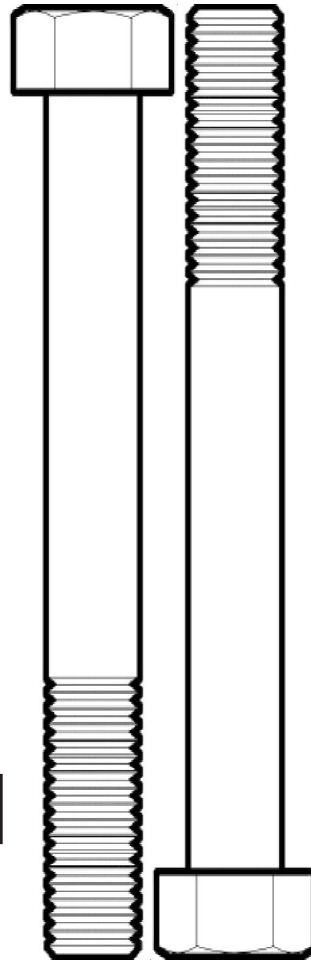

**1/4-20 x 0.5" Buttonhead  
Socket Cap Screw (x4)**



**1/2-13 x 4.5"  
Hex Bolts  
(x2)**

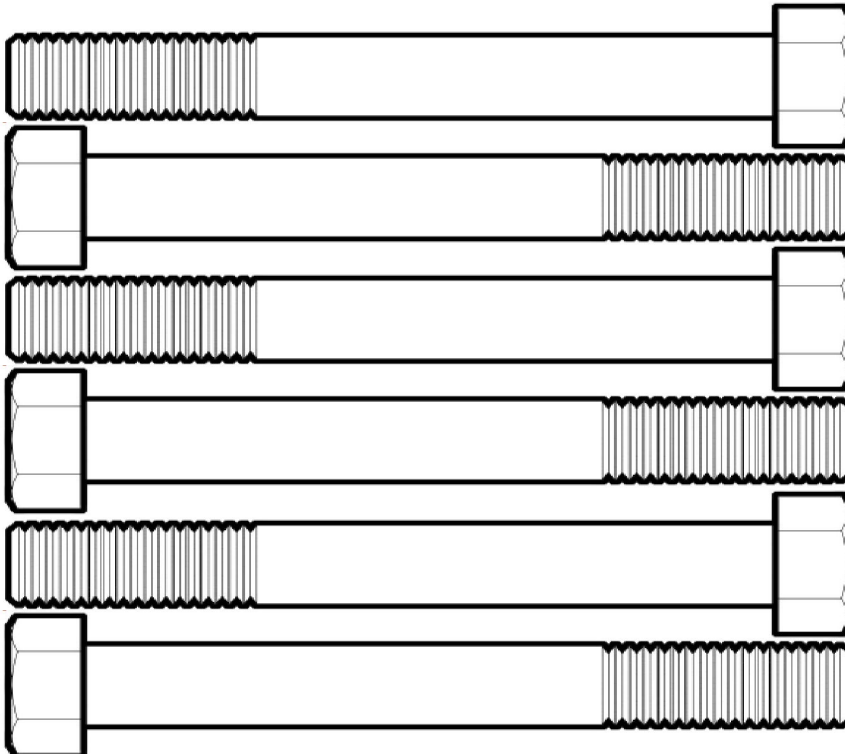

**1/2-13 x 4" Hex Bolts  
(x6)**



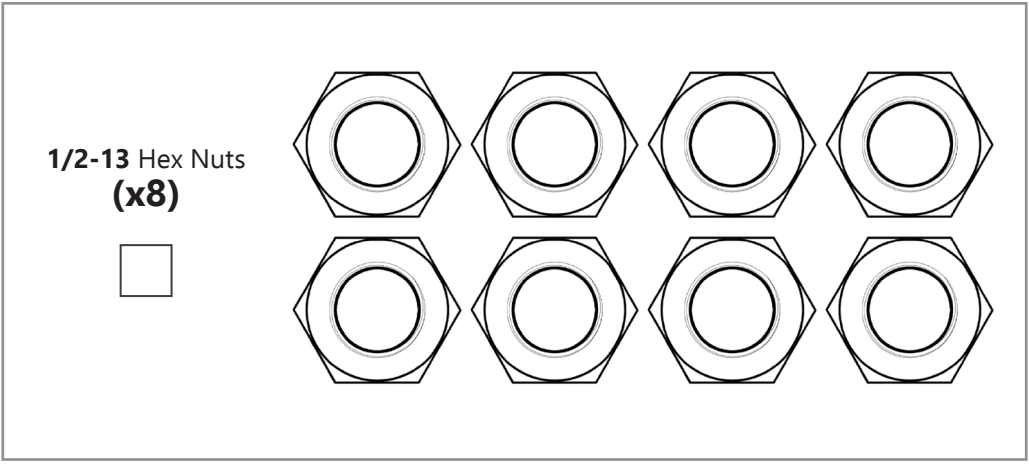

1/2" Washers  
**(x16)**

