



# INSTALLATION GUIDE

**PART NUMBER: 5568**

**REAR ANTI-SWAY BAR**

**CHEVROLET CAMARO | 1967-1981**

**CHEVROLET NOVA | 1968-1979**

**PONTIAC FIREBIRD | 1967-1981**

**300 W. PONTIAC WAY. CLOVIS, CA 93612**

**PHONE: 800-445-3767 | EMAIL: INFO@BELLTECH.COM**

# THANK YOU

Thank you for choosing our high quality Belltech product. We have spent a great deal of time developing our line of products so that you will receive maximum performance with minimal difficulty during installation. Soon your vehicle will be on the road looking and feeling much improved.

**Please take a moment to read all instructions and warnings prior to installation of your new Belltech product and before operating your vehicle. If you have any questions or concerns regarding any step in the installation process, please do not hesitate to call or email our customer support specialists who are trained to help you through any portion of this process.**

## Before You Begin:

**It is of the utmost importance that you confirm all the components listed on the parts list are in the kit. You can find this list located on the last page(s) of your instructions. Do not begin installation if any part is missing. Instead, please call our Belltech customer service specialists.**

### Belltech Customer Support:

Phone: 1-800-445-3767

Email: [info@belltech.com](mailto:info@belltech.com)

## Safety Information:

**Warning:** Do not work under a vehicle supported only by a jack. Place support stands securely under the vehicle in the manufacturer's specified locations unless otherwise instructed.

Proper use of safety equipment and eye/face/hand protection is necessary when performing any of the following instructions.

We strive for an exceptional experience for all our valued customers. If for any reason you need assistance with your Belltech products, please do not return the product to the store you purchased from, but rather call our dedicated customer service experts, from 7am to 5pm PST.

We recommend that a qualified mechanic, in a properly equipped facility, perform this installation.

It is very helpful to have an assistant available during installation.

## Before Driving Your Vehicle:

It is important to double check all brake hoses, cables, and other components to be sure there is no interference. You must also check for wheel/tire to chassis/body interference. If any issues are found, review your installation instructions to be sure no steps were missed, and any problems are corrected.

Make sure your vehicle is aligned immediately following installation.

Check all hardware and torque at intervals for the first 10, 100, and 1000 miles.

Some of Belltech's products are designed to improve your vehicle's off-road performance. Leveling/lifting your vehicle may result in an altered center of gravity. It is crucial to use extreme care when operating your vehicle to prevent rollover and/or loss of control.

Any changes in your vehicle's suspension may result in transformed handleability. Please test-drive your vehicle in a remote location so you can become accustomed to the revised driving characteristics.

Perform headlight check and adjustment.

Failure to drive any modified vehicle in a safe manner may result in harm or death.

Never operate your modified vehicle under the influence of drugs, alcohol, or lack of adequate sleep.

Always wear your seatbelt.



**DIFFICULTY:**

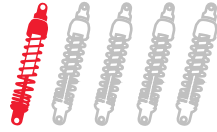

**INSTALLATION TIME:** 1 Hour

## RECOMMENDED TOOLS:

- Properly rated floor jack
- Support stands
- Wheel chocks
- Metric and standard socket wrench set
- Metric and standard wrench set
- Drill with drill bit set
- Safety glasses
- Torque wrench rated up to 100 ft lbs.

## JACKING, SUPPORTING, AND PREPARING THE VEHICLE

1. Park your vehicle on a smooth, level, concrete, or seasoned asphalt surface.
2. Block the front wheels of the vehicle using wheel chocks. Make sure the vehicle's transmission is in "PARK" (automatic) or first gear (manual).
3. Activate the parking brake.
4. Loosen, but do not remove, the rear wheel lug nuts.
5. Lift the rear of the vehicle off the ground using a properly rated floor jack. Lift the vehicle so the rear tires are approximately 6-8 inches off the ground.
6. Place support stands rated for the vehicle's weight. The stands must be positioned in the factory specified locations. (Refer to the owner's manual). Prior to lowering the vehicle onto stands, make sure the support stands will contact the chassis. It is very important that the vehicle is properly supported to prevent any harm to oneself or to the vehicle.
7. Lower the vehicle slowly onto the stands.
8. Remove the rear wheels.



### Technician reminder:

Never work under a vehicle supported only by a jack. It is necessary to place support stands securely under the vehicle in the manufacturer's specified locations unless otherwise instructed.

# BELLTECH ANTI-SWAY BAR INSTALLATION

9. Thoroughly lubricate the inside of the supplied pivot bushings using the grease packet included with the kit.
10. Place the bushings on both sides of the Belltech sway bar, as close to the outside arms as possible, just before the bend. Once located, rotate the bushings slightly to evenly spread the lubricant. Place the bushing brackets over the bushings.



11. Ensure there is 1/32" to 1/16" of the bushing is showing after the bracket is seated. If the bushing is showing more than 1/16", use a sander or a sheet of coarse grit sandpaper to shave it down to the proper height.

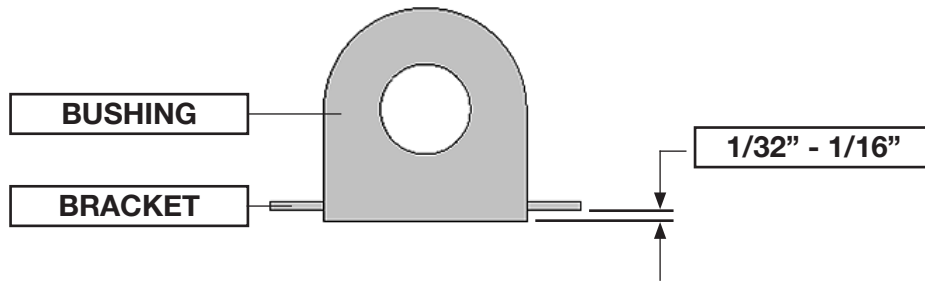

12. Place the U-bolts over the axle tube and under the brake line, ensuring the brake line is not clamped underneath, if needed, bend the hydraulic line away from the axle. Place the U-clamp on the U-bolt followed by the support plate. With the sway bar arms pointed toward the front of the vehicle, mount the sway bar and bushing bracket on the U-clamp. Hand tighten the supplied nuts on the U-bolt for now. Ensure the sway bar is positioned below the axle.

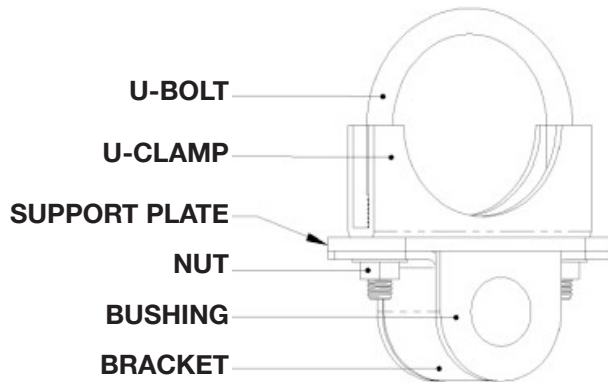

## BELLTECH ANTI-SWAY BAR INSTALLATION CONTINUED

13. The end links will be assembled through the end link brackets and the ends of the Belltech sway bar as shown in the diagram below.

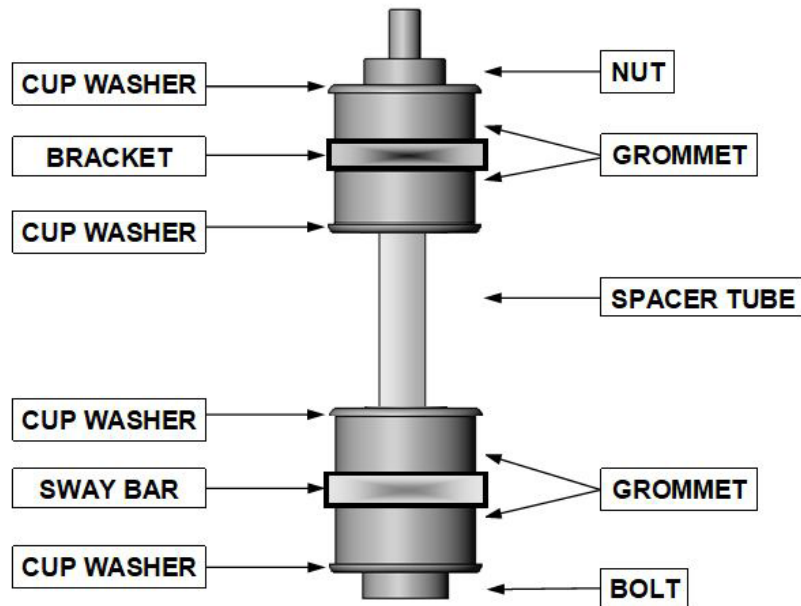

14. Assemble the end links to the Belltech sway bar, as shown in the diagram.

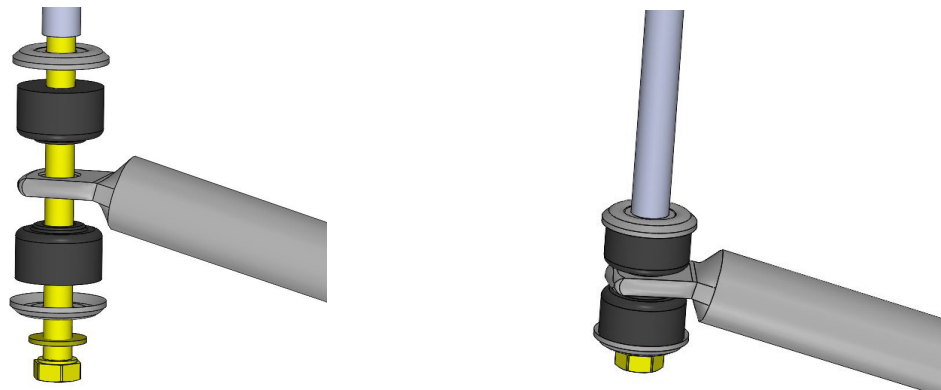



## BELLTECH ANTI-SWAY BAR INSTALLATION CONTINUED

- Center the sway bar left to the right and front to rear. Position the U-bolts and clamps to the widest spacing possible to prevent the sway bar from shifting left or right while cornering. Use a floor jack to raise the rear axle until the jack stands just begin to unload. Check for vehicle stability.
- Line up the arms of the Belltech sway bar so they are an even distance from the frame rails. Attach the end link assembly as shown in the diagram on page 4 but do not torque. The long leg of the end link bracket is attached to the end link.
- Hold the arms of the sway bar horizontal with the ground, use the end link brackets as a template. The short leg of the end link bracket is mounted to the frame. Mark the frame through the hole in the bracket. Swing the arms down and drill a 1/2" hole on both sides of the frame through the mark made on each frame rail.



### Technician warning:

Before drilling, check for electrical, fuel, and brake system components on the inside of the frame rail being drilled. Relocate the components as necessary so they are not damaged during the frame modification.



- Remove the bracket from the end link assembly and mount the short leg to the frame. Secure the bracket to the frame with a 1/2"-13 x 3-1/2" bolt, 1/2" Nyloc nut, and 1/2" washers. Place the small washer between the head of the bolt and the bracket. Place the large washer between the Nyloc nut and the frame. Torque to 37 ft lbs.

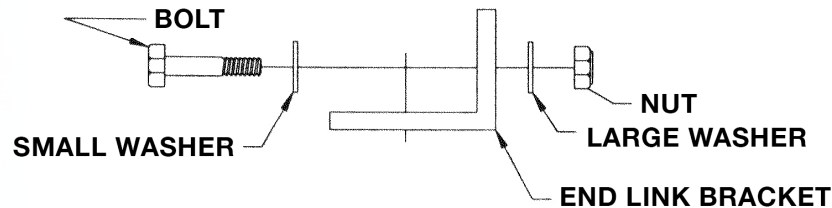

- Attach the end link assemblies to the Belltech sway bar and the end link brackets as before. Tighten the end link bolt to the point where the spacer tube can still be forced to rotate on the bolt by hand, but the rubber grommets should not be able to rotate by hand.
- Torque the U-bolts and pivot bushing clamps to 22 ft lbs.

# FINALIZING THE INSTALLATION

21. Mount the wheels and tighten the lug nuts
22. Lift the vehicle and remove the support stands.
23. Carefully lower the vehicle onto flat ground.
24. Torque the lug nuts to 90 ft lbs.
25. Check that all components and fasteners have been properly installed and torqued.
26. Read and perform all tasks in the “Before Driving Your Vehicle” section of page 1 of your instructions.

## THANK YOU FOR CHOOSING BELLTECH.

You are now a part of the Belltech family and we are eager to catch a glimpse of your newly modified vehicle. Give us a shout out and let us know how much you love our product. Don't forget, we offer other Belltech related merchandise for you and your vehicle on our website [www.belltech.com](http://www.belltech.com)

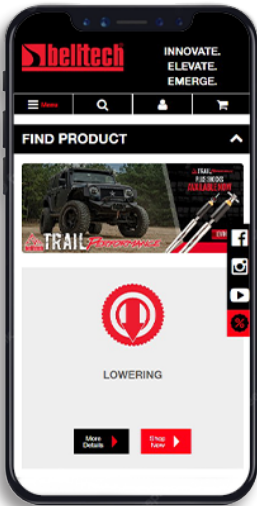

[belltechsuspension](https://www.facebook.com/belltechsuspension)



[Belltech Suspension](https://www.youtube.com/BelltechSuspension)



[@belltechsuspension](https://www.instagram.com/belltechsuspension)

If you have any questions, concerns, or warranty related issues regarding your Belltech product, please call or email our experienced customer service specialists.

### Belltech Customer Support:

Phone: 1-800-445-3767

Email: [info@belltech.com](mailto:info@belltech.com)

# KIT CONTENTS



SWAY BAR KIT		
Part number	Description	Qty
51045-300	7/8" REAR ANTI-SWAY BAR	1
51045-777	HARDWARE KIT	1

HARDWARE KIT		
Part number	Description	Qty
112322	1/2"-13 NYLOC NUT	2
110255	3/8"-16 NYLOC NUT	4
112212	1/2"-13 X 3-1/2" BOLT	2
112130	3/8"-16 X 5-1/2" BOLT	2
110660	1/2" SMALL WASHER	2
112538	1/2" LARGE WASHER	2
110625	3/8" WASHER	4
112502	CUP WASHER	8
112406-95	1-1/4" SPACER TUBE	2
113000	END LINK GROMMET	8
51005-005-95	END LINK BRACKET	2
112258	3" U-CLAMP ASSEMBLY	2
113205	7/8" PIVOT BUSHING	2
114032-95	PIVOT BUSHING BRACKET	2
114038-95	BUSHING SUPPORT PLATE	2
55000-10	WHITE LITHIUM GREASE	1





**KW automotive North America, Inc.**

300 W. Pontiac Way

Clovis, CA 93612

Phone: +1-559-875-0222

Toll Free: 1-800-445-3767

[belltech.com](http://belltech.com)