



# INSTALLATION GUIDE

**PART NUMBER: 5521**  
**REAR ANTI-SWAY BAR**  
**GM COLORADO / CANYON 2WD | 2004-2012**

300 W. PONTIAC WAY CLOVIS, CA 93612  
PHONE: 800-445-3767 | EMAIL: [INFO@BELLTECH.COM](mailto:INFO@BELLTECH.COM)

# THANK YOU

Thank you for choosing our high quality Belltech product. We have spent a great deal of time developing our line of products so that you will receive maximum performance with minimal difficulty during installation. Soon your vehicle will be on the road looking and feeling much improved.

**Please take a moment to read all instructions and warnings prior to installation of your new Belltech product and before operating your vehicle. If you have any questions or concerns regarding any step in the installation process, please do not hesitate to call or email our customer support specialists who are trained to help you through any portion of this process.**

## Before You Begin:

**It is of the utmost importance that you confirm all the components listed on the parts list are in the kit. You can find this list located on the last page(s) of your instructions. Do not begin installation if any part is missing. Instead, please call our Belltech customer service specialists.**

### Belltech Customer Support:

Phone: 1-800-445-3767

Email: [info@belltech.com](mailto:info@belltech.com)

## Safety Information:

**Warning:** Do not work under a vehicle supported only by a jack. Place support stands securely under the vehicle in the manufacturer's specified locations unless otherwise instructed.

Proper use of safety equipment and eye/face/hand protection is necessary when performing any of the following instructions.

We strive for an exceptional experience for all our valued customers. If for any reason you need assistance with your Belltech products, please do not return the product to the store you purchased from, but rather call our dedicated customer service experts, from 7am to 5pm PST.

We recommend that a qualified mechanic, in a properly equipped facility, perform this installation.

It is very helpful to have an assistant available during installation.

## Before Driving Your Vehicle:

It is important to double check all brake hoses, cables, and other components to be sure there is no interference. You must also check for wheel/tire to chassis/body interference. If any issues are found, review your installation instructions to be sure no steps were missed, and any problems are corrected.

Make sure your vehicle is aligned immediately following installation.

Check all hardware and torque at intervals for the first 10, 100, and 1000 miles.

Some of Belltech's products are designed to improve your vehicle's off-road performance. Leveling/lifting your vehicle may result in an altered center of gravity. It is crucial to use extreme care when operating your vehicle to prevent rollover and/or loss of control.

Any changes in your vehicle's suspension may result in transformed handleability. Please test-drive your vehicle in a remote location so you can become accustomed to the revised driving characteristics.

Perform headlight check and adjustment.

Failure to drive any modified vehicle in a safe manner may result in harm or death.

Never operate your modified vehicle under the influence of drugs, alcohol, or lack of adequate sleep.

Always wear your seatbelt.



**DIFFICULTY:**



**INSTALLATION TIME:** 1-2 Hours

## RECOMMENDED TOOLS:

- Properly rated floor jack
- Support stands
- Wheel chocks
- Metric and standard socket wrench set
- Metric and standard wrench set
- Drill with drill bit set
- Safety glasses
- Torque wrench rated up to 150 ft lbs.

## JACKING, SUPPORTING, AND PREPARING THE VEHICLE

1. Park your vehicle on a smooth, level, concrete, or seasoned asphalt surface.
2. Block the front wheels of the vehicle using wheel chocks. Make sure the vehicle's transmission is in "PARK" (automatic) or first gear (manual).
3. Activate the parking brake.
4. Loosen, but do not remove, the rear wheel lug nuts.
5. Lift the rear of the vehicle off the ground using a properly rated floor jack. Lift the vehicle so the rear tires are approximately 6-8 inches off the ground.
6. Place support stands rated for the vehicle's weight. The stands must be positioned in the factory specified locations. (Refer to the owner's manual). Prior to lowering the vehicle onto stands, make sure the support stands will contact the chassis. It is very important that the vehicle is properly supported to prevent any harm to oneself or to the vehicle.
7. Lower the vehicle slowly onto the stands.
8. Remove the rear wheels.



### Technician reminder:

Never work under a vehicle supported only by a jack. It is necessary to place support stands securely under the vehicle in the manufacturer's specified locations unless otherwise instructed.

## BELLTECH ANTI-SWAY BAR INSTALLATION

9. Thoroughly lubricate the inside of the supplied pivot bushings using the grease packet included with the kit.
10. Place the bushings on both sides of the Belltech sway bar, centered on the first set of bends. Once located, rotate the bushings slightly to evenly spread the lubricant. Place the bushing brackets over the bushings.



11. Ensure there is  $1/32''$  to  $1/16''$  of the bushing is showing after the bracket is seated. If the bushing is showing more than  $1/16''$ , use a sander or a sheet of coarse grit sandpaper to shave it down to the proper height.

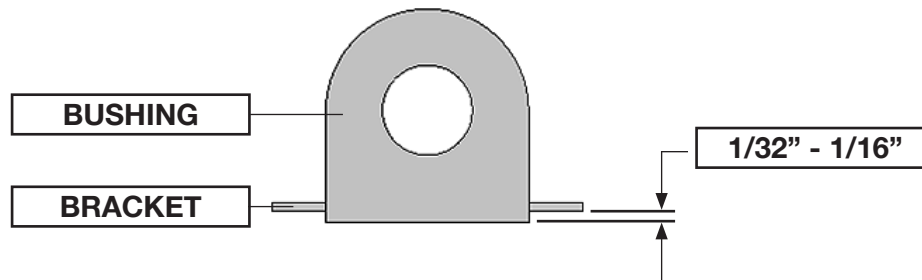

12. Position the Belltech sway bar behind the axle with the bar ends pointed toward the rear of the vehicle, angled up.

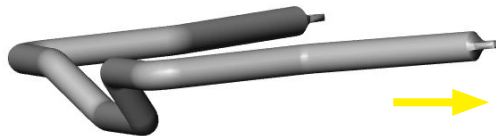

# BELLTECH ANTI-SWAY BAR INSTALLATION CONTINUED

13. Carefully push the hydraulic line away from the axle and place the U-bolts over the axle tube and under the brake line, ensuring the brake line is not clamped underneath. Place the U-clamp on the U-bolt followed by the support plate. Mount the sway bar and bushing bracket on the U-clamp. Hand tighten the supplied nuts on the U-bolt for now. The sway bar is positioned vertically behind the axle.

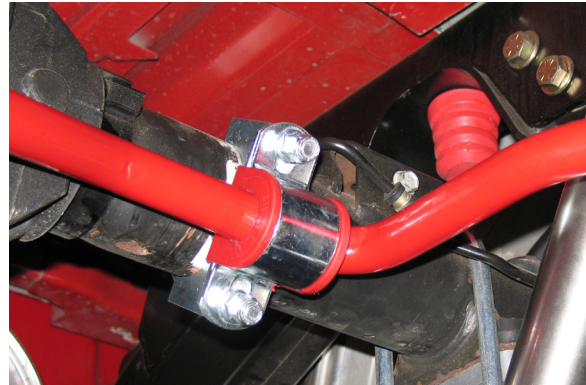
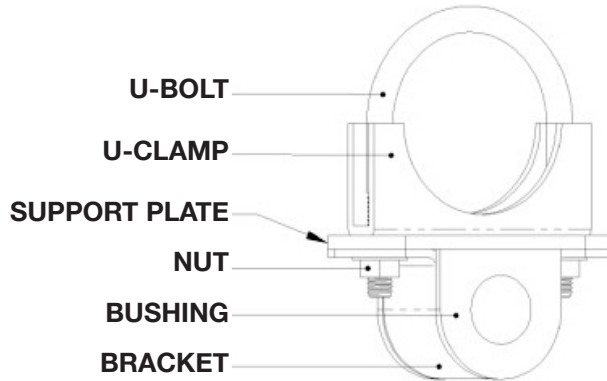

14. Position the U-bolts and clamps to the widest spacing possible and center the sway bar left to the right. This will prevent the sway bar from shifting left or right while cornering.
15. Place a floor jack under the rear axle to lift it just until the suspension is loaded. Ensure not to lift the vehicle off the jack stands. This will simulate the vehicles' weight on the floor.
16. Assemble the end links and end link brackets on the ends of the sway bar as shown in the diagram below. Place the end link bolt in from above so the bolt head faces up and the nut is at the bottom. Hand tighten the Nyloc nuts but to do torque yet.

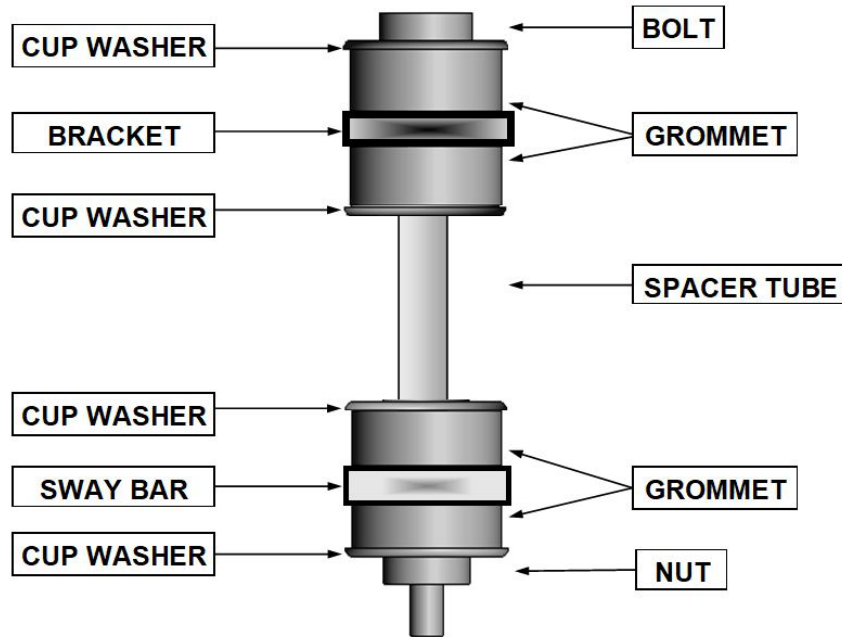

## BELLTECH ANTI-SWAY BAR INSTALLATION CONTINUED

17. Swing the sway bar up and position the ends of the arms as parallel as possible with the frame. Mark the position of the end link bracket against the frame.

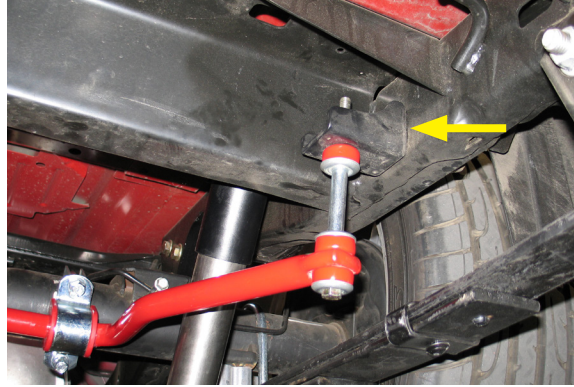

18. Measure 1" up from the bottom of the frame; make a mark. Center punch the mark and drill a 1/2" hole through both sides of the frame. On the inside of the frame only, enlarge the 1/2" hole to a 3/4" hole. The larger hole is for the larger spacer tube, and it is only required on the inside of the frame.



19. Place the spacer tube, from the inside of the frame, and fasten the upper end link bracket to the frame with a 1/2"-13 x 3-1/2" bolt, two 1/2" washers, and a flange nut. Torque to 20 ft lbs.



20. Tighten the end link nuts to the point where the spacer tube can still be forced to rotate on the bolt by hand, but the grommets should not be able to rotate by hand. Torque the U-bolts and pivot bushing clamps to 20 ft lbs.



# FINALIZING THE INSTALLATION

21. Mount the wheels and tighten the lug nuts
22. Lift the vehicle and remove the support stands.
23. Carefully lower the vehicle onto flat ground.
24. Torque the lug nuts to 103 ft lbs.
25. Check that all components and fasteners have been properly installed and torqued.
26. Read and perform all tasks in the “Before Driving Your Vehicle” section of page 1 of your instructions.

## THANK YOU FOR CHOOSING BELLTECH.

You are now a part of the Belltech family and we are eager to catch a glimpse of your newly modified vehicle. Give us a shout out and let us know how much you love our product. Don't forget, we offer other Belltech related merchandise for you and your vehicle on our website [www.belltech.com](http://www.belltech.com)

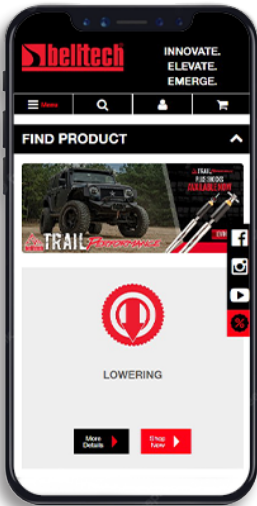

[belltechsuspension](https://www.facebook.com/belltechsuspension)



[Belltech Suspension](https://www.youtube.com/BelltechSuspension)



[@belltechsuspension](https://www.instagram.com/belltechsuspension)

If you have any questions, concerns, or warranty related issues regarding your Belltech product, please call or email our experienced customer service specialists.

### Belltech Customer Support:

Phone: 1-800-445-3767

Email: [info@belltech.com](mailto:info@belltech.com)

# KIT CONTENTS



SWAY BAR KIT		
Part number	Description	Qty
5521-300	1" REAR ANTI-SWAY BAR	1
5521-777	HARDWARE KIT	1

HARDWARE KIT		
Part number	Description	Qty
112424-95	2-3/4" SPACER TUBE	2
112138	3/8"-16 X 6-1/2" BOLT	2
110255	3/8"-16 NYLOC NUT	2
112502	CUP WASHER	8
113000	END LINK GROMMET	8
6612-014-95	2-3/16" SPACER TUBE	2
112212	1/2"-13 X 3-1/2" BOLT	2
110400	1/2"-13 FLANGE NUT	2
112538	1/2" WASHER	4
5524-003-99	END LINK BRACKET	2
112258	3" U-CLAMP	2
113075	1" PIVOT BUSHING	2
114026-95	PIVOT BUSHING BRACKET	2
114038-95	BUSHING SUPPORT PLATE	2
55000-10	WHITE LITHIUM GREASE	1