



INSTALLATION GUIDE

PART NUMBER: 5519
REAR ANTI-SWAY BAR
GM SILVERADO / SIERRA 1500 2WD / 4WD | 2019-2024

****FOR LOWERED APPLICATIONS USING BELLTECH FLIP KIT 6528 ONLY****

300 W. PONTIAC WAY CLOVIS, CA 93612
PHONE: 800-445-3767 | EMAIL: INFO@BELLTECH.COM

THANK YOU

Thank you for choosing our high quality Belltech product. We have spent a great deal of time developing our line of products so that you will receive maximum performance with minimal difficulty during installation. Soon your vehicle will be on the road looking and feeling much improved.

Please take a moment to read all instructions and warnings prior to installation of your new Belltech product and before operating your vehicle. If you have any questions or concerns regarding any step in the installation process, please do not hesitate to call or email our customer support specialists who are trained to help you through any portion of this process.

Before You Begin:

It is of the utmost importance that you confirm all the components listed on the parts list are in the kit. You can find this list located on the last page(s) of your instructions. Do not begin installation if any part is missing. Instead, please call our Belltech customer service specialists.

Belltech Customer Support:

Phone: 1-800-445-3767

Email: info@belltech.com

Safety Information:

Warning: Do not work under a vehicle supported only by a jack. Place support stands securely under the vehicle in the manufacturer's specified locations unless otherwise instructed.

Proper use of safety equipment and eye/face/hand protection is necessary when performing any of the following instructions.

We strive for an exceptional experience for all our valued customers. If for any reason you need assistance with your Belltech products, please do not return the product to the store you purchased from, but rather call our dedicated customer service experts, from 7am to 5pm PST.

We recommend that a qualified mechanic, in a properly equipped facility, perform this installation.

It is very helpful to have an assistant available during installation.

Before Driving Your Vehicle:

It is important to double check all brake hoses, cables, and other components to be sure there is no interference. You must also check for wheel/tire to chassis/body interference. If any issues are found, review your installation instructions to be sure no steps were missed, and any problems are corrected.

Make sure your vehicle is aligned immediately following installation.

Check all hardware and torque at intervals for the first 10, 100, and 1000 miles.

Some of Belltech's products are designed to improve your vehicle's off-road performance. Leveling/lifting your vehicle may result in an altered center of gravity. It is crucial to use extreme care when operating your vehicle to prevent rollover and/or loss of control.

Any changes in your vehicle's suspension may result in transformed handleability. Please test-drive your vehicle in a remote location so you can become accustomed to the revised driving characteristics.

Perform headlight check and adjustment.

Failure to drive any modified vehicle in a safe manner may result in harm or death.

Never operate your modified vehicle under the influence of drugs, alcohol, or lack of adequate sleep.

Always wear your seatbelt.



DIFFICULTY:

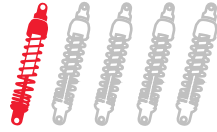

INSTALLATION TIME: 1-2 Hours

RECOMMENDED TOOLS:

- Properly rated floor jack
- Support stands
- Wheel chocks
- Metric and standard socket wrench set
- Metric and standard wrench set
- Drill with drill bit set
- Safety glasses
- Torque wrench rated up to 150 ft lbs.

JACKING, SUPPORTING, AND PREPARING THE VEHICLE

1. Park your vehicle on a smooth, level, concrete, or seasoned asphalt surface.
2. Block the front wheels of the vehicle using wheel chocks. Make sure the vehicle's transmission is in "PARK" (automatic) or first gear (manual).
3. Activate the parking brake.
4. Loosen, but do not remove, the rear wheel lug nuts.
5. Lift the rear of the vehicle off the ground using a properly rated floor jack. Lift the vehicle so the rear tires are approximately 6-8 inches off the ground.
6. Place support stands rated for the vehicle's weight. The stands must be positioned in the factory specified locations. (Refer to the owner's manual). Prior to lowering the vehicle onto stands, make sure the support stands will contact the chassis. It is very important that the vehicle is properly supported to prevent any harm to oneself or to the vehicle.
7. Lower the vehicle slowly onto the stands.
8. Remove the rear wheels.



Technician reminder:

Never work under a vehicle supported only by a jack. It is necessary to place support stands securely under the vehicle in the manufacturer's specified locations unless otherwise instructed.

BELLTECH ANTI-SWAY BAR INSTALLATION

9. Locate the square tubed crossmember in front of the rear axle. Measure 1.5" inches from the outside edge of the frame toward the center of the frame; mark the distance at the center of the square crossmember. Drill a 7/16" hole into the frame until you pass through the square crossmember.



10. Attach the end link U-bracket to the crossmember with a 3/8"-16 x 2-1/4" bolt, two 3/8" washers, and a Nyloc nut. Torque the bolt to 80 ft lbs.



11. Assemble the end link as shown in the image below. Attach the end link assembly to the U-bracket with a 3/8"-16 x 2-1/4" bolt, two 3/8" washers, and a Nyloc nut. The washers are placed on each side of the bracket. Hand tighten, do not torque yet.

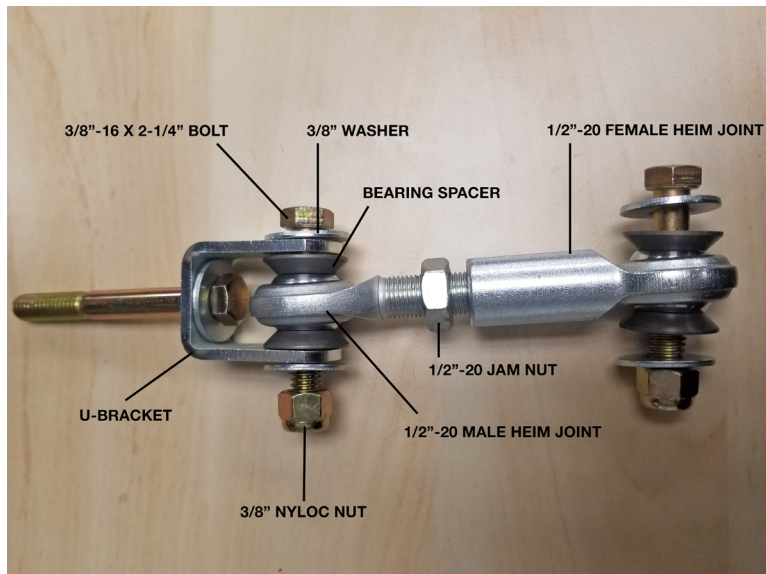

Technician note:

Tighten the jam nut to ensure the end link remains at the set length.

BELLTECH ANTI-SWAY BAR INSTALLATION CONTINUED

12. Thoroughly lubricate the inside of the supplied pivot bushings using the grease packet included with the kit.
13. Place the bushings on both sides of the Belltech sway bar, centered on the first set of bends. Once located, rotate the bushings slightly to evenly spread the lubricant. Place the bushing brackets over the bushings.



14. Ensure there is $1/32''$ to $1/16''$ of the bushing is showing after the bracket is seated. If the bushing is showing more than $1/16''$, use a sander or a sheet of coarse grit sandpaper to shave it down to the proper height.

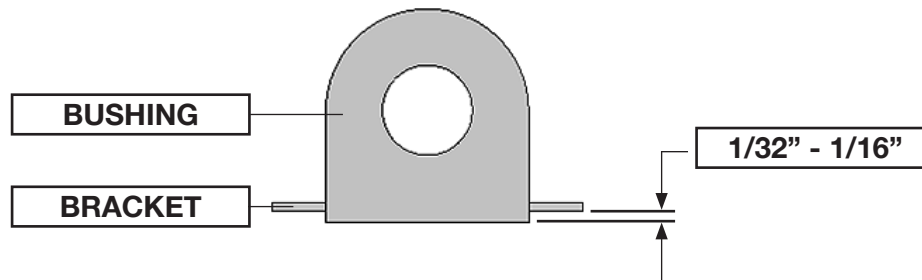

15. Position the Belltech sway bar under the axle with the bar ends pointed toward the front of the vehicle, angled up.

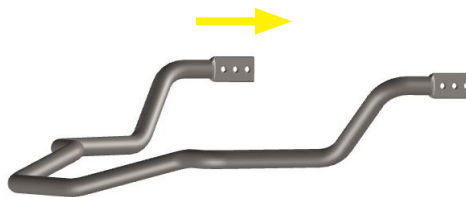

BELLTECH ANTI-SWAY BAR INSTALLATION CONTINUED

16. Carefully bend the hydraulic line away from the axle and place the U-bolts over the axle tube and under the brake line, ensuring the brake line is not clamped underneath. Place the U-clamp on the U-bolt followed by the support plate. Mount the sway bar and bushing bracket on the U-clamp. Hand tighten the supplied nuts on the U-bolt for now. Ensure the sway bar is positioned below the axle.

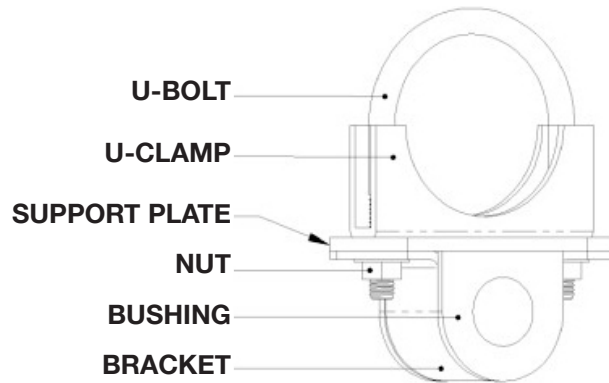

17. Center the sway bar left to the right and front to rear. Center the U-bolts and clamps between the first set of bends.
18. Please choose a sway bar setting for your vehicle: SPORT, SPORT PLUS, OR TOWING (SPORT is softer and TOWING is firmer).

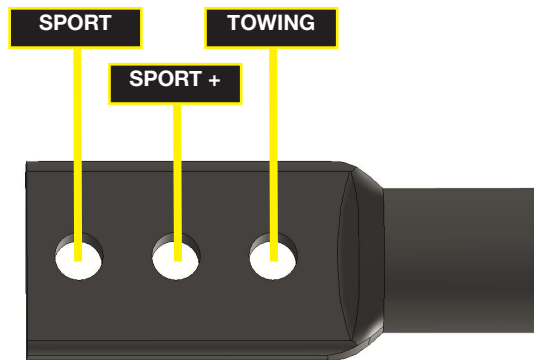

19. Attach the bottom of each end-link assembly onto the Belltech sway bar with 3/8"-16 x 2-1/4" bolts, 3/8" washers, and Nyloc nuts. Ensure the washers are placed between the sway bar, the bolt head, and the Nyloc nut. The end-links must be inboard of the sway bar. Torque the end link bolts to 44 ft lbs.



Technician reminder:

The end links are adjustable; adjust the end links to set the sway bar parallel with the ground. This is easier to achieve once the vehicle is flat on the ground.



20. Torque the U-bolt nuts to 19 ft lbs.

FINALIZING THE INSTALLATION

21. Mount the wheels and tighten the lug nuts
22. Lift the vehicle and remove the support stands.
23. Carefully lower the vehicle onto flat ground.
24. Torque the lug nuts to 140 ft lbs.
25. Check that all components and fasteners have been properly installed and torqued.
26. Read and perform all tasks in the “Before Driving Your Vehicle” section of page 1 of your instructions.

THANK YOU FOR CHOOSING BELLTECH.

You are now a part of the Belltech family and we are eager to catch a glimpse of your newly modified vehicle. Give us a shout out and let us know how much you love our product. Don't forget, we offer other Belltech related merchandise for you and your vehicle on our website www.belltech.com

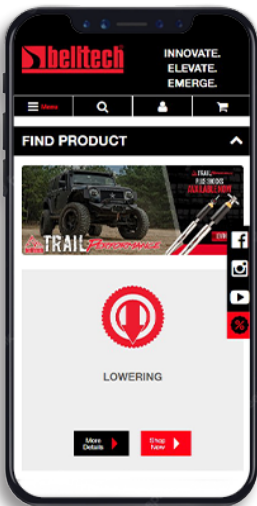

belltechsuspension



Belltech Suspension



@belltechsuspension

If you have any questions, concerns, or warranty related issues regarding your Belltech product, please call or email our experienced customer service specialists.

Belltech Customer Support:

Phone: 1-800-445-3767

Email: info@belltech.com

KIT CONTENTS

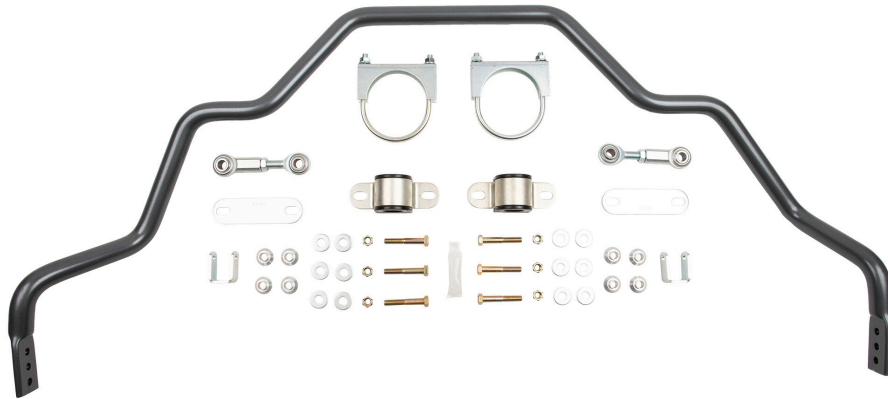

SWAY BAR KIT		
Part number	Description	Qty
5519-300	1-1/8" REAR ANTI-SWAY BAR	1
5519-777	HARDWARE KIT	1

HARDWARE KIT		
Part number	Description	Qty
57400-045	BEARING SPACER	8
112106	3/8"-16 X 2-1/4" BOLT	6
71001-007-95	END LINK U- BRACKET	2
112249	1/2"-20 FEMALE HEIM JOINT	2
112326	1/2"-20 JAM NUT	2
112248	1/2"-20 MALE HEIM JOINT	2
110255	3/8"-16 NYLOC NUT	6
113085	1-1/8" PIVOT BUSHING	2
115002-95	PIVOT BUSHING BRACKET	2
115003-95	BUSHING SUPPORT PLATE	2
112260	3-1/4" U-CLAMP	2
112518	3/8" WASHER	12
55000-10	WHITE LITHIUM GREASE	1