



Alumilite Steps

part# 840121412937

DIRECTIONS FOR INSTALLATION & USE

**2001- 2018 CHEV/GMC Silverado/Sierra 1500
& 2001-2019 Chevrolet/GMC Silverado/Sierra
2500/3500**

CREW CAB (FULL 4-DOOR)

Works with Diesel DEF Tanks

*For technical support,
call **1-800-626-8746** or email **sales@icionline.com**
visit icionline.com to download instructions*



ATTN: STATE OF CALIFORNIA CONSUMERS
WARNING: CANCER AND REPRODUCTIVE HARM
-WWW.P65WARNINGS.CA.GOV



WARNING: FAILURE TO COMPLY WITH INSTALLATION,
SAFETY, AND PRODUCT USE INSTRUCTIONS MAY RESULT IN
SERIOUS BODILY INJURY OR DEATH.

IMPORTANT NOTES

The contents of this installation and operation manual should be read and comprehended before initializing the installment of the above listed product. This will help minimize risk to injury through the installation process and through the operation of the product.

TABLE OF CONTENTS













1. SAFETY, WARNINGS, AND OPERATION	02
2.PARTS AND TOOLS REQUIRED	03
4.REFERENCE DIAGRAM.	04-08
5. ICI STEP INSTALLATION.	09-12
6. SOCIAL MEDIA REFERENCE	12



SAFETY, WARNINGS, AND OPERATION

- Please ensure that the installer and end-user of this product have familiarized themselves with the contents in this manual. This manual provides important information about the possible safety and operation risks that are involved with the usage of this product.
- Our number one concern is the safety of our customers. This product is intended to be installed by a professional to minimize risk of an improper installation. Improper installations can lead to product damage, vehicle damage, and bodily injury. We ask that you reach out for professional assistance if this installation is beyond your capabilities.
- Please ensure to safeguard this installation and operation manual to reference in the future or to pass on to a future owner of the product.
- Please follow all instructions and take all safety precautions necessary throughout the entirety of the installation process.

PARTS AND TOOLS REQUIRED

SYMBOL	DESCRIPTION	TOOL	DESCRIPTION
	HAZARDOUS WARNING		RATCHET/SOCKET WRENCH
	WARNING: SHARP ELEMENTS		SOCKETS : 13mm
	WARNING: CRUSHING OF HANDS		13mm
	WARNING: HOT SURFACE		(Allen wrench included)
	MANDATORY: WEAR EYE PROTECTION		EYE PROTECTION
			DRILL GUN (01-06 models only)
			5/16" DRILL BIT (01-06 models only)

PARTS AND TOOLS REQUIRED

Hardware Kit includes:

- (1). Qty x 1 = M8 x 40mm Hex Head Bolts
- (2). Qty x 15 = M8 x 25mm Hex Head Bolts
- (3). Qty x 20 = M8 x 30mm Hex Countersunk Bolts
- (4). Qty x 15 = M8 Lock Washers
- (5). Qty x 20 = M8 Finish Washers
- (6). Qty X 1 = M8 x 28 x 3mm Flat Washers
- (7). Qty x 36 = M8 x 24 x 2mm Flat Washers
- (8). Qty x 15 = M8 U-Clip Nuts
- (9). Qty x 21 = M8 Nylock Nuts
- (10). Qty x 4 = 5/16" x 1" Type B Hex Head Self-Threading Screws
- (11). Qty x 1 = T-bolt

Compenents List:

- (a). Side Bars - Qty x 2
1 Driver / 1 Passenger
- (b). Passenger Front Bracket - 2 piece Bracket - Qty x 1
First piece (100546) / Second piece (100547)
- (c). Front / Mid-Front / Rear Brackets - Qty x 5
3 Driver / 2 Passenger (100544)
- (d). Mid-Rear Bracket - Qty x 2
1 Driver / 1 Passenger (100545)

REFERENCE DIAGRAM

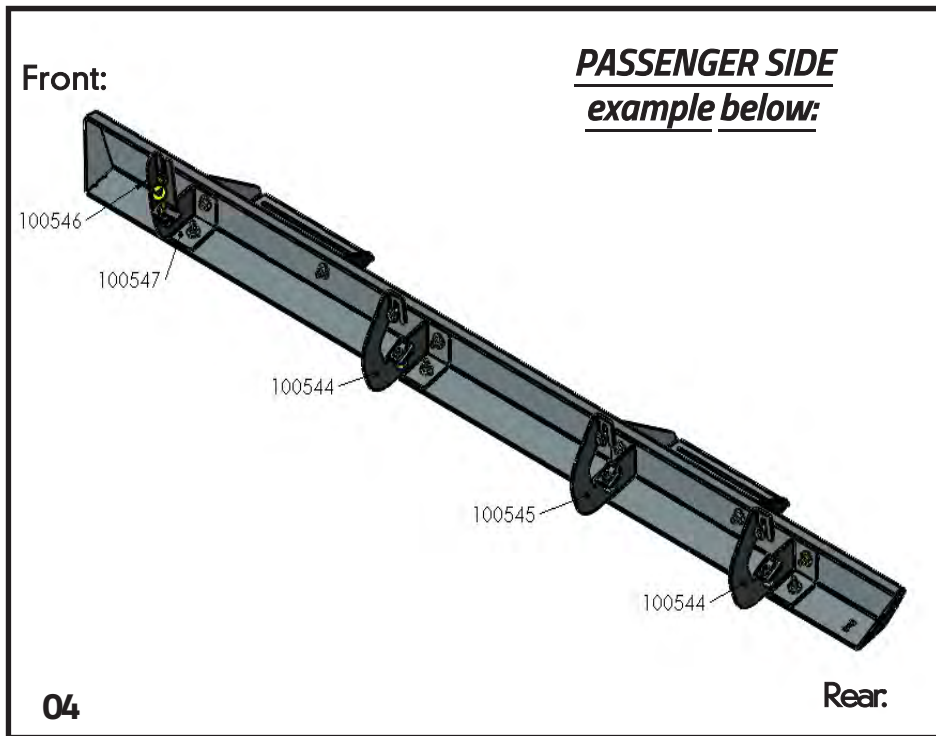
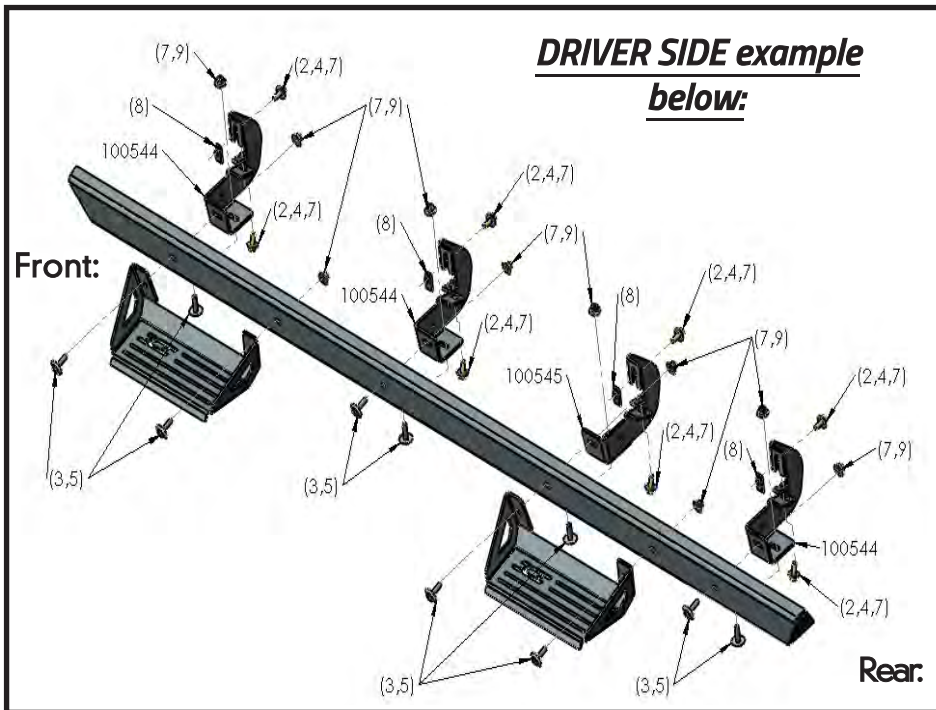

REFERENCE DIAGRAM

***Passenger Front Bracket set-up (2-piece bracket)
Accommodates DIESEL DEF TANK
Use for both Gas and Diesel models***

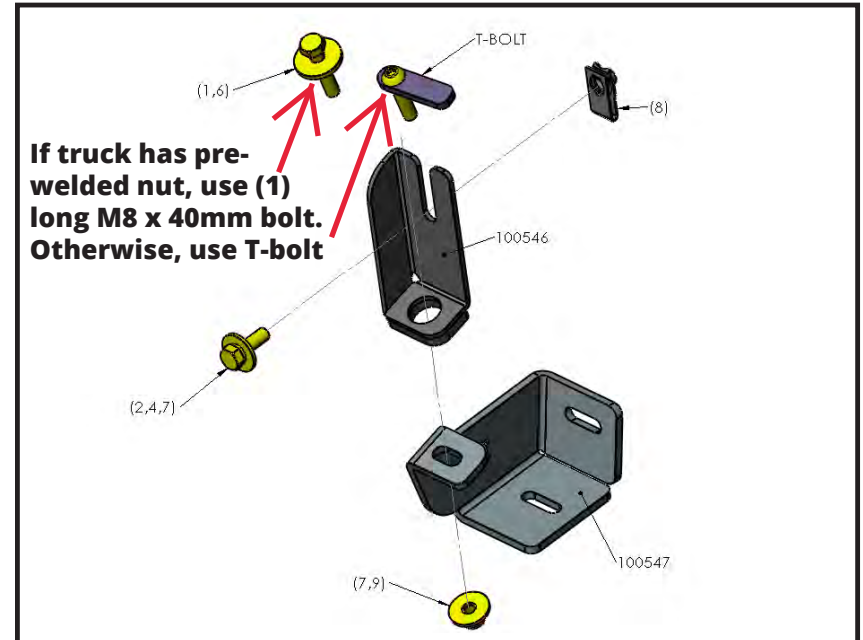

REFERENCE DIAGRAM 01-06 Classic Body Only

Retro Bracket fit instructions only for 2001-2006 Classic Chev/GMC models.

-Drilling required for the last 2 brackets on both the Driver and Passenger side (100545 and 100544)

-The 2001-2006 models did not come with pre-drilled holes in these locations. Without drilling, the last 2 brackets cannot be bolted to the truck. See below for instructions. *Skip ahead to page 8 if truck year is a 2007+ or newer.*

Required Tools:

- 5/16" Drill Bit
- Drill

Required Hardware:

- Qty x 4 = 5/16" x 1" Type B Hex Head Self-Threading Screws

Step A (Locate and drill Pinch-weld holes)

Note that the front two bracket locations have pre-drilled holes in the pinch-weld and inner rocker panel. Use diagram below to locate the 3rd and 4th pinch-weld hole locations.



REFERENCE DIAGRAM 01-06 Classic Body Only



Step B (Locate and Drill inner rocker panel holes)

Note the pinch-weld holes and inner rocker panel holes are vertically aligned and centered. Using the newly drilled pinch-weld holes, hold up the 3rd and 4th brackets to the truck and mark the inner rocker panel holes. Then, set brackets off to the side and drill the inner rocker panel holes using the mark.



REFERENCE DIAGRAM (Set-up for U-Clip Nuts)

Bracket set-up tips for all vehicles

-Each bracket has 2 mounting points on the truck, one in the inner rocker panel and one in the pinch-weld . Note that the holes are vertically aligned.

-On some vehicles, the inner rocker panel hole (top hole) and pinch weld hole (bottom) may already be pre-threaded by the factory. If so, do not use the M8 U-Clip Nuts as they are not needed.

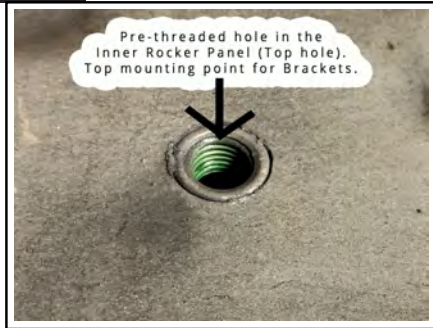

If the mounting point holes are not pre-threaded, reference the set-up guide below:

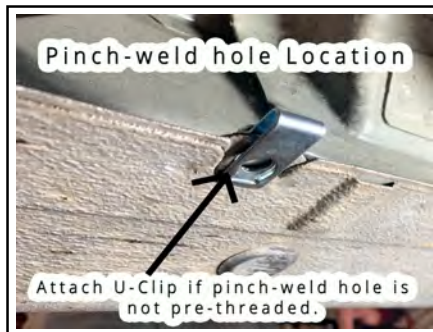
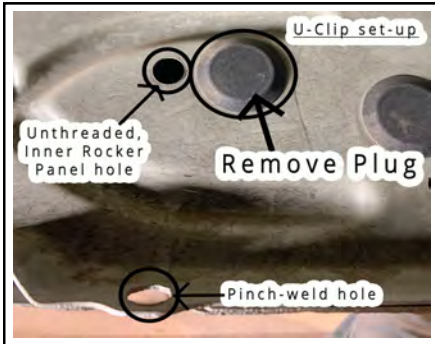

ICI STEP INSTALLATION

Step 1 (Prep)

Beginning on the passenger side, remove any steps if equipped. Next, locate the 4 sets of mounting points on the underside of the vehicle. Note that vehicle may have tape or plugs covering the mounting locations. These will need to be removed so that the mounting locations can be accessed. Hole locations may be pre-threaded. If not, reference diagram on pg. 9 for U-Clip set up.

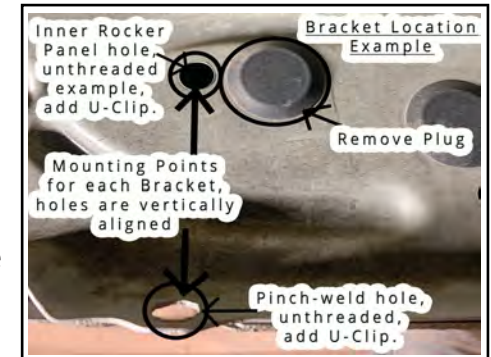

Figure 1.

Step 2 (Install Front Passenger Bracket to Truck)

Begin with the passenger front brackets (2 piece bracket) 100546 and 100547. Reference diagram on pg. 6 for set-up. If truck has pre-threaded pinch-weld nut, use (1 set) of M8x40mm hex head bolt and M8x3mm large washer, otherwise use T-Bolt. Then, use M8x25mm hex head bolt, M8 nylock nut, and (2) M8 washers. Use a 13mm socket and do not fully tighten yet.



Figure 2.

Step 3 (Install Brackets to Truck)

Next, move onto the Mid-Front bracket (100544). If needed, add U-clips to mounting points on truck. Use (2 sets) of M8 hex head bolts, Lock washers, and flat washers. Use a 13mm socket and do not fully tighten yet. Once the Mid-Front bracket is attached, move on to the Mid-Rear bracket (100545) then the Rear bracket (100544), repeating the steps above for each bracket.



Figure 3.

ICI STEP INSTALLATION

Step 4 (Hang bar on Brackets)

Next, locate the passenger side bar. The three holes on the front half of the bar are farther spaced than the three holes on the rear half of the bar. Reference diagram on page 6. The top of the bar has a small lip, use the lip to hang the bar on the brackets. This will make the installation process easier and hands-free.



Figure 4.

Step 5 (Bolt Mid-Front Bracket and Rear Bracket to Bar)

Next, bolt the Mid-Front bracket (100544) to the bar, 3rd hole from front of bar. Use (2 sets) of M8 finish washers, M8x24x2mm flat washers, M8x35mm hex countersunk bolts, and M8 Nylock Nuts. Use a 13mm socket and the provided Allen wrench. Do not fully tighten.

Repeat steps above for Rear Bracket (100544), last hole from front of bar. See diagram on page 6 for reference.

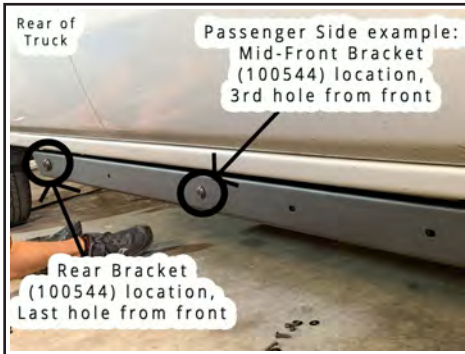

Figure 5.

Step 6 (Bolt Front Bracket to Bar and Front Hoop Step)

Bolt the Front Bracket to the Bar and front hoop step. Then finish bolting hoop step to the bar. View diagram on page 6. Note that the hoop step and front bracket share a bolt. Use (3 sets) of M8 finish washers, flat washers, hex countersunk bolts, and nylock nuts. Use a 13mm socket and the provided Allen wrench. Do not fully tighten.

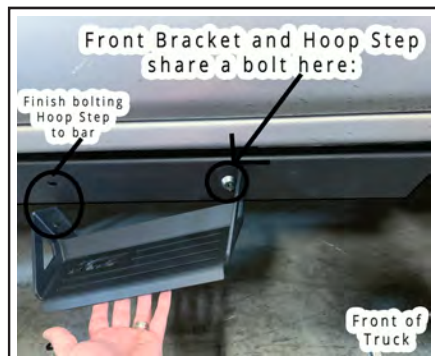

Figure 6.

ICI STEP INSTALLATION

Step 7 (Bolt Mid-Rear Bracket to Bar and Rear Hoop Step)

Bolt the Mid-Rear bracket (100545) to the Bar and rear hoop step. Then finish bolting hoop step to the bar. View diagram on page 6. Note that the hoop step and mid-rear bracket share a bolt. Use (3 sets) of M8 finish washers, flat washers, hex countersunk bolts, and nylock nuts. Use a 13mm socket and the provided Allen wrench. Do not fully tighten.

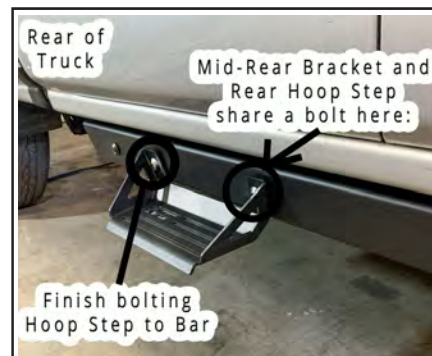

Figure 7.

STEP 8 (Tighten Brackets to Truck)

Make sure all 4 brackets, the bar, and the 2 hoop steps are loosely fitted to each other and to the vehicle. Using a 13mm socket, fully tighten the front bracket to the vehicle, make sure the bracket is flush with the mounting surface. Repeat on the other brackets, checking the bracket alignment as needed.

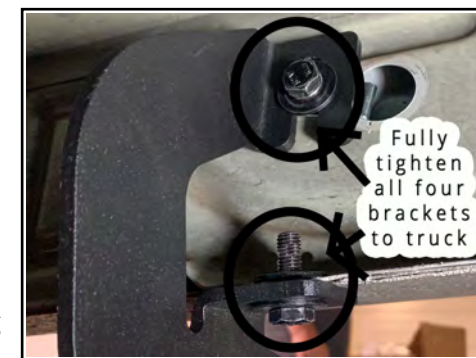

Figure 8.

STEP 9 (Tighten Brackets to the Bar and Hoop-Steps)

Now, adjust the bar from front to back and tighten the bar to the brackets with a 13mm socket and provided Allen wrench. Make sure the bar is flush with the front and bottom face of the brackets

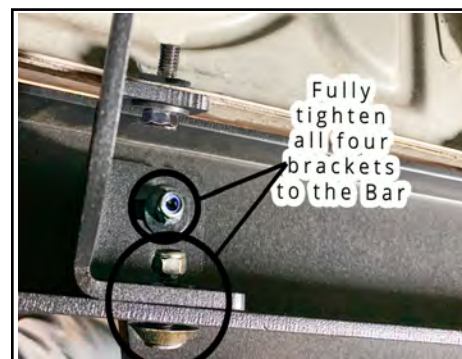

Figure 9.

***PROTIP:** When tightening the Finish Washers, hold the Allen Key tight so the Bolt does not spin. Then, tighten the Nut on the backside. This will prevent the Bolt and Finish Washer from spinning and scratching the Bar.

ICI STEP INSTALLATION

STEP 10 (Finish)

Check all hardware and make sure they are fully tightened. Reference diagram on page 4 for hardware locations. Repeat Steps 1-10 for the Driver Side. Note that the Driver side front bracket (100544) is the same as the Mid-Front and Rear brackets (100544). Installation is the same.



Figure 10.

AMAZING!

You have successfully completed the installation of your new Alumilite steps. Time to flex on your friends through Social Media! Don't forget to Tag us!

Drop us a Review!



www.facebook.com/InnovativeCreationsInd



www.instagram.com/ici_usa



Hashtags:

*#ICIUSA
#ICIALumilite
#AlumiliteSteps
#AlumiliteBumpers*