

Heavy Duty Front Bumper Toyota Tundra

2009-2020 Toyota Tundra Non-winch with/without Sensors

AL-FBM62TYN-RT

10/16/20

Hardware Kit Includes:

- (1) 8 – M12-1.5 Hex Head Nuts Grade 8
- (2) 8 – M12 Lock washer Grade 8
- (3) 8 – M12 Flat washer Grade 8
- (4) 8 – M12 Plastic push nuts
- (5) 4 – M8 x 25mm Hex Head Bolts Grade 8
- (6) 4 – M8 Flat Washers 24mm OD Grade 8
- (7) 4 – M8 Flanged Hex Head Nuts Grade 8

Components List:

- 1 – Heavy Duty Bumper FBM89TYN
- 2 – Mounting brackets (BP5182)
- 4 – M12-1.5 Double T-Bolt BP5186
- 1 – RT Light Mount
- 2 – RT Light Mount Foam Gaskets
- 4 – RT Light Mount Hole Plugs
- 2 – Plastic Sensor Plugs
- 2 – Bumper/Bracket Insulator (100298)
- 2 – License Plate Hole Plugs

**LOOSE FIT ALL COMPONENTS.
DO NOT TIGHTEN UNTIL ALL
COMPONENTS ARE INSTALLED
AND ADJUSTED.**



ATTN: STATE OF CALIFORNIA CONSUMERS
WARNING: CANCER AND REPRODUCTIVE HARM
-WWW.P65WARNINGS.CA.GOV

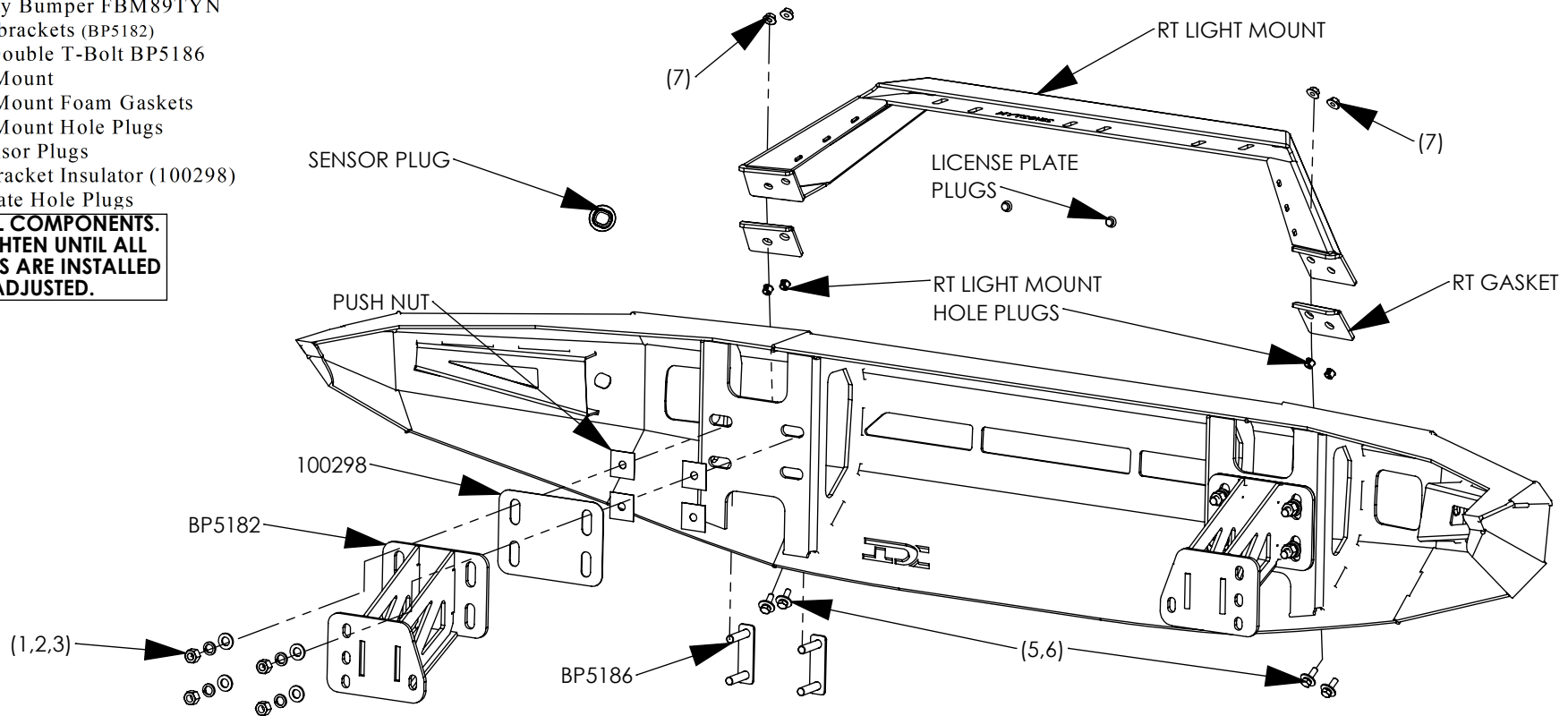

Heavy Duty Front Bumper Toyota Tundra

2009-2020 Toyota Tundra Non-winch with/without Sensors

AL-FBM62TYN-RT

10/16/20

2009-2013 Front Bumper Removal

- STEP 1.** First step before you begin, open all packaging, and remove the hardware package and inspect it for completeness. Read instructions completely.
- STEP 2.** Open hood of vehicle and disconnect negative battery terminal.
- STEP 3.** Remove lower front factory skid plate and put aside, remove factory tow hooks and hardware, save the hardware for reinstallation later.
- STEP 4.** Locate and remove the lower front inner fender liner splash guards on either side by removing plastic push tabs, screw tabs and lower attaching bolts on the bottom of the factory bumper.
- STEP 5.** Disconnect wiring to the factory fog lamps and the sensors (if so equipped).
- STEP 6.** Begin removal of the lower-main bumper by unbolting the eight 14mm hex head nuts at the frame, remove lower plastic push tabs attached to the lower cross member and carefully remove bumper.

2014-2020 Front Bumper Removal

- STEP 1.** First step before you begin, open all packaging, and remove the hardware package and inspect it for completeness. Read instructions completely.
- STEP 2.** Open hood of vehicle and disconnect negative battery terminal.
- STEP 3.** Begin by removing the factory grille assembly. Remove and save the four 10mm hex head bolts attaching the upper tabs to the core support mounts. Lift up gently on the tabs and pull outward toward the front of the truck. Release the lower spring clips tabbed in near the bottom inner sides of the grille and remove the grille. Set aside for re-installation after removal of the factory bumper.
- STEP 4.** Next unplug the fog lamp plug from the rear of the lamp assembly (if so equipped). Also remove the retaining clip attaching the wiring harness to the inside bumper support bracket. Unplug parking sensor harness (if so equipped), leave sensors in bumper until after removal.
- STEP 5.** Next unbolt the lower valance from underneath the front bumper. Remove the four hex head screws and the two plastic push tabs and let the valance hang down freely.
- STEP 6.** Now remove the intermediate cross brace located behind the bumper and in front of the radiator. Remove the five hex head nuts and put aside to be reinstalled later.
- STEP 7.** Now remove the factory bumper by unbolting the eight 14mm hex head nuts (4 per side) attaching the bumper to the frame, save for reuse with the Alumilite bumper. Once all bumper hardware has been removed slide the bumper off of the studs away from the vehicle and set aside.

Alumilite Front Bumper Installation

- STEP 8.** Begin installation of the Alumilite Bumper by installing the BP5182 brackets onto the factory frame bumper mounting location utilizing the factory 14mm hex head nuts removed in the previous step. Align brackets making sure they are level, then snug the factory nuts down but do not fully tighten until after the bumper has been installed and adjusted. Remove factory parking sensors (if equipped) from the stock bumper. Remove retaining clip from the backside of the bumper and slide sensor out through the front of the bumper. Transfer over to the new Alumilite Bumper reusing the factory mounting hardware in the reverse order in which they were removed, if not equipped with sensors install the provided plugs into the sensor holes in the Alumilite bumper. Now is also a good time to install the RT bar if desired.
- STEP 9.** On the new Alumilite Bumper, install the four BP5186 T-Bolts into the bumper inside mounting brackets and attach using the supplied plastic push nuts. Now with help, lift and support the bumper. Place the plastic insulators (100298) over the T-bolts so that when the bumper is installed, they are between the bumper and brackets. This will isolate the aluminum and steel parts. Carefully slide the bumper onto the BP5182 brackets on the frame and align the T-Bolts with the slots in the brackets. Attach using the supplied M12 flat washers, lock washers, and hex head nuts. Carefully align the bumper from side to side and up and down. Once you are satisfied with the fit tighten all M12 hardware. Next fully tighten the eight factory 14mm hex head nuts to the frame. If equipped, Plug in parking sensor harness into sensors and check for proper function, if not use provided plastic plugs to fill holes.
- STEP 10.** If you are installing lights into your new bumper, do so now into the mounting tab locations provided in the bumper and wire to the manufacture's specifications. ICI recommends that you re-torque all mounting hardware after 50-100 miles of driving. Enjoy your new ALUMILITE BUMPER!