

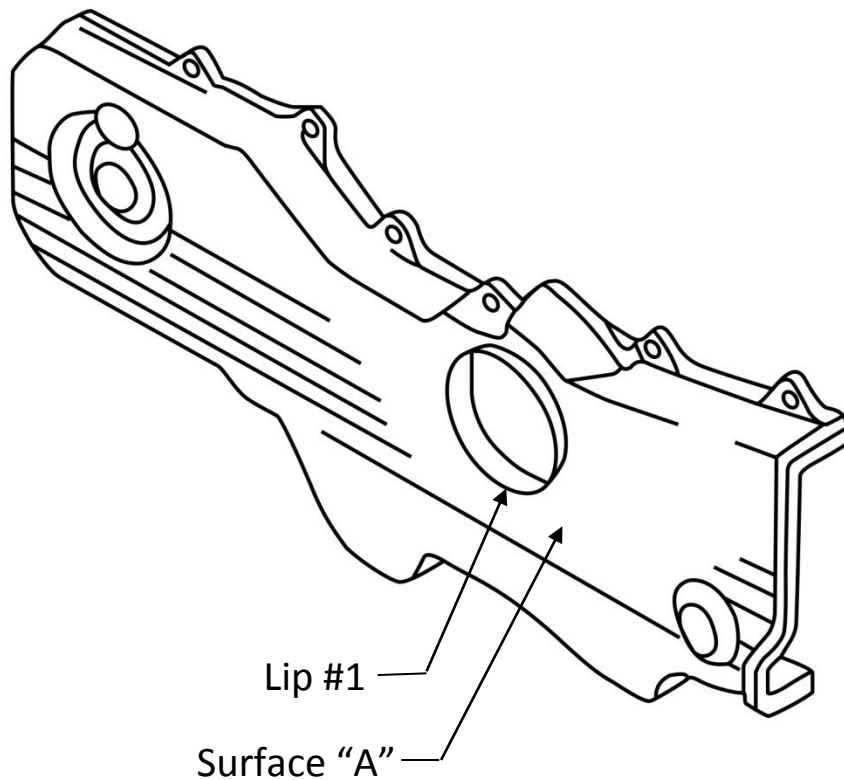

WARNING:

MODIFICATION OF THE TIMING COVER IS
REQUIRED BEFORE INSTALLATION OF
PART NUMBER 531101 FLUIDAMPR

Cut, trim or grind lip #1 to be flush with surface "A", to clear the
back of the fluidampr.



Please contact Fluidampr Customer Tech for any comments, suggestions or
questions.

Phone: 716-592-1000

Web: www.fluidampr.com

E-mail: support@fluidampr.com

P/N 4NFL02

Revised 8/2019