

INSTALLATION of P/N 610701 & 630701:

Pre 1995 Models: Before installation, check timing cover clearance.
Trim plastic cover lip if necessary.

Bolt Fluidampr to existing gear, torque the
(4) M8x1.25 bolts to 240 in/lbs. (20 ft/lbs.) at assembly

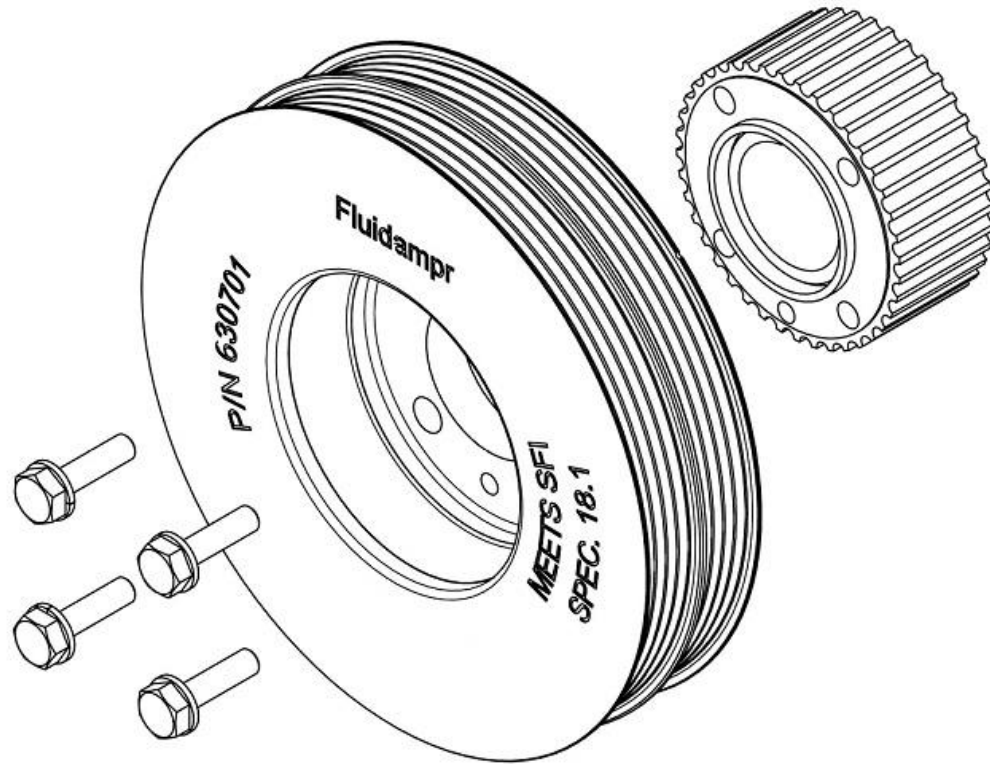

Refer to Step 2 – Balancing, Internally Balanced Engines Section

Please contact Fluidampr Customer Tech for any comments, suggestions or questions.

Phone: 716-592-1000

Web: www.fluidampr.com

E-mail: support@fluidampr.com

P/N 4NFF06

Revised 8/2019