

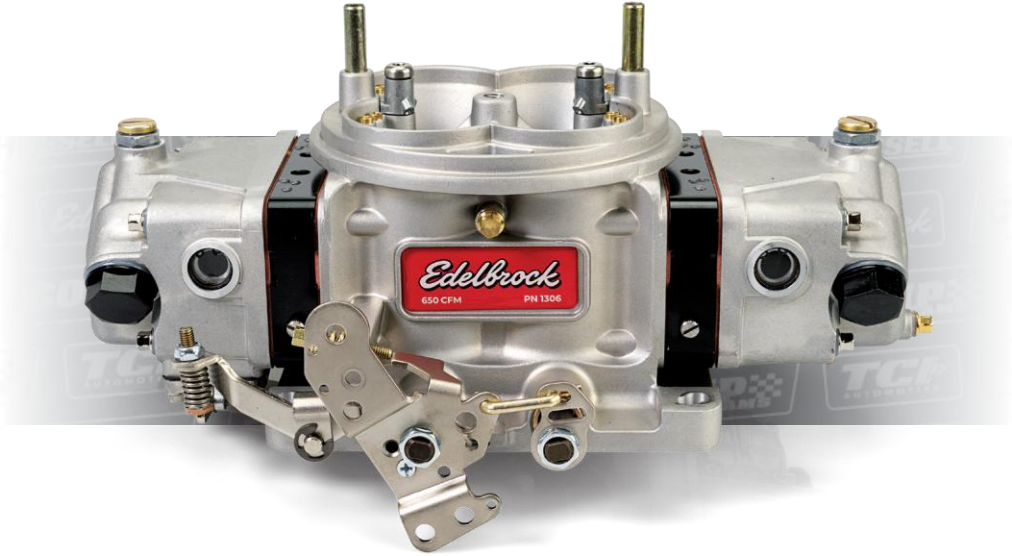

VRS-4150™
E85 SERIES CARBURETOR



INSTALLATION INSTRUCTIONS



EDELBROCK® VRS-4150™ E85 RACE AND PERFORMANCE SERIES CARBURETOR

INSTALLATION INSTRUCTIONS

PLEASE study these instructions carefully before beginning this installation. Most installations can be accomplished with common tools and procedures. However, you should be familiar with and comfortable working on your vehicle. If you do not feel comfortable performing this installation, it is recommended to have the installation completed by a qualified mechanic. If you have any questions, please call our **Technical Hotline at: 1-800-416-8628**, 7:00 am - 7:00 pm, Central Standard Time, Monday through Friday.

DESCRIPTION: Edelbrock VRS-4150 E85 Carburetors have been calibrated, factory flow-tested, and preset. Please read all instructions prior to installation. **Edelbrock VRS-4150 Carburetors are non-emissions carburetors, check your local emissions laws before installing.**

KIT CONTENTS: VRS-4150 - E85

- Installation Instruction Sheet
- Warranty Card
- Square-Bore Base Gasket
- Air Cleaner Gasket
- Air Cleaner Stud (5/16" -18 UNC)
- Black Primary to Secondary Link Ultra Progressive
- Silver Primary to Secondary Link (1:1 Opening Rate)

TOOLS RECOMMENDED FOR INSTALLATION

- Sockets/Wrenches/AN Wrenches
- 1/4" Hex Nut Drive
- Screwdrivers & Torx Driver (TPS Cover)

PARTS RECOMMENDED FOR INSTALLATION

- PN 8024 Carburetor Stud Kit Zinc Finish 1 3/4" Overall Length
- PN 1224 or 1225 14" Round Air Cleaner with 3/8 deep flange and Cotton Element
- Fuel System Regulated to 7 psi maximum and 5 psi minimum. Use of low-pressure high flow components recommended.
- PN 36018 Throttle Position Sensor (if desired)
- PN 8041 Throttle Cable Bracket
- PN 8005 Universal Throttle Return Spring Kit (or equivalent)
- New E-85 rated Fuel Filters

CHECK THE FOLLOWING BEFORE BEGINNING INSTALLATION

- **BEFORE INSTALLATION: Verify that all fuel lines, fittings, regulators, and fuel filters are E85 compatible.**
- Replace or add an in-line fuel filter. Dirt (i.e. corrosion residue or other debris) found in carburetor will void your warranty.
- Check and replace the air filter if necessary.
- Check PCV valve and replace it if clogged.
- Check all hoses for leaks or cracks and replace as necessary.
- Check fuel system for proper operation. Replace or upgrade if necessary.
- Check the intake manifold and cylinder head gaskets for leaks and replace if necessary.
- Check the ignition system: clean and gap or replace spark plugs, plug wires, and adjust ignition timing to proper specifications.

IMPORTANT WARNINGS REGARDING YOUR EDELBROCK VRS-4150 E85 CARBURETORS

For a Successful Installation, Read This Page Before Beginning the Installation.

WARNING: Proper installation is the responsibility of the installer. Improper installation will void your warranty and may result in poor performance and engine or vehicle damage.

When working around raw fuel, always work in a well-ventilated area and keep all open flames, sparks, and other sources of ignition away from the work area. Failure to do so can result in a FIRE or EXPLOSION.

- **Edelbrock VRS-4150 Race and Performance carburetors ARE NOT for computer-controlled applications.** This includes some 1981 & later GM vehicles with Rochester Q-Jet carburetor (*will have a 2-wire plug that connects to the front of the carb*) and some 1981 & later Ford vehicles with automatic overdrive (AOD) transmissions.
- **The use of a new fuel filter between the fuel pump and carburetor is required.** Failure to do so will void the manufacturer's warranty of the carburetor. It's good practice to keep the filter away from heat and not allow it to contact any part of the engine. **(ALL FUEL FILTERS, FITTINGS, AND LINES MUST BE E85 COMPATIBLE)**
- **Do not use more than 7 psi fuel pressure.** Excessive fuel pressure may cause flooding. If the vehicle has an adjustable fuel-pressure regulator, it is highly recommended to set it to 6.0 psi. With most fuel pumps, the minimum fuel pressure is encountered at high rpm and wide-open-throttle. Fuel pressure should not drop below 2.0 psi. If it does, a fuel pump with more capacity may be required. Edelbrock mechanical or electric fuel pumps are highly recommended for all Edelbrock VRS-4150 carburetors.
- **Excessive under-hood temperature:** Ensure fuel line is not located too close to heat sources such as the exhaust or block, causing expanding fuel to be forced past the needle and seat. Fuel can also boil inside the carburetor due to missing gaskets, spacers, or heat shields. For additional information on Insulator Spacers, please visit our website at www.edelbrock.com.

WARNING: EDELBROCK E85 SERIES CARBURETORS ARE ONLY CALIBRATED FOR E85 FUEL. USE OF ALCOHOL, METHANOL, OR OTHER FUELS IN YOUR EDELBROCK E85 CARBURETOR WILL DAMAGE YOUR CARBURETOR AND VOID ALL MANUFACTURE'S WARRANTIES. ALL CALIBRATION WAS COMPLETE WITH E85 FUEL CONTAINING AN ETHANOL CONTENT OF 85%. VARIATIONS IN ETHANOL CONTENT CAN AFFECT PERFORMANCE. IT IS RECOMMENDED TO TEST THE ETHANOL CONTENT OF THE E85 USED IN ORDER TO ACHIEVE DESIRED RESULTS.

- If the vehicle will be sitting for an extended period, the carburetor should be cleaned/flushed with gasoline. This prevents the carburetor from becoming gummed up.
- The E85 specific VRS carburetors contain components that were specifically developed for use with **E85 FUEL ONLY**. With these specific components (metering block, booster passages, etc.), the carburetor cannot be run on gasoline.

If you have any questions or concerns with the installation or performance, do not return to the carburetor to the retailer...call the Edelbrock Carb Tech Hotline at 800-416-8628 from 7am - 7pm CST Monday-Friday.

Please also visit the Edelbrock website to view the complete Owner's Manual, carburetor calibration reference carts and other technical information not found in these instructions.

INSTALLATION PROCEDURE

Figure 1 - Fittings and Vacuum Port Locations

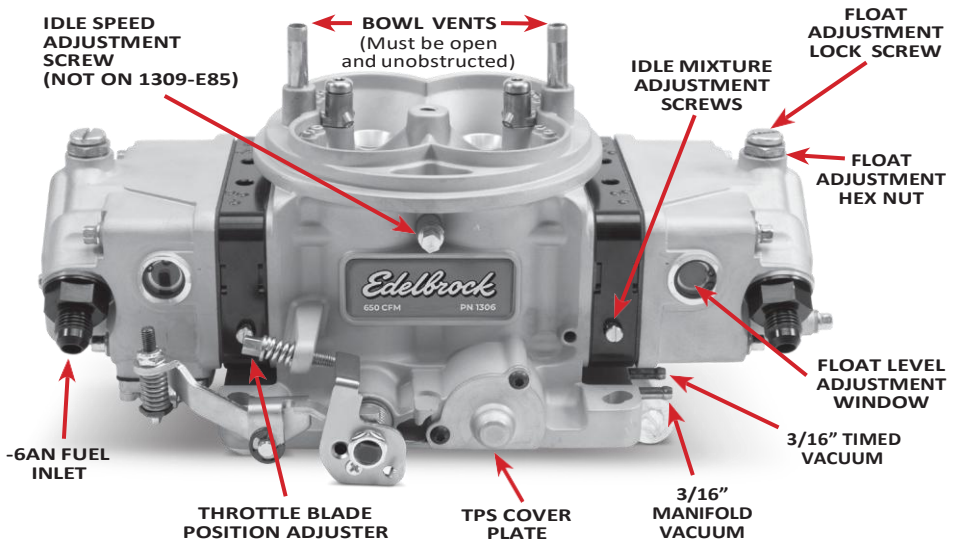

BEFORE REMOVING OLD CARBURETOR

1. Determine if the distributor vacuum port is timed (no vacuum at idle) or full (vacuum present at idle). With the engine at operating temperature and idling, pull the vacuum advance hose off the carburetor and “feel” for vacuum by putting your finger on the vacuum port (**See Fig. 2**). If you feel vacuum it uses full time vacuum. If you need to crack open the throttle to feel vacuum your distributor uses timed vacuum.

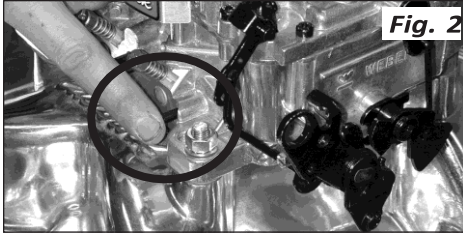

2. If your distributor has timed vacuum advance, you will hook the vacuum hose from the distributor to the inner 3/16” diameter vacuum port on the new carburetor. If it has full vacuum advance, it will be hooked up to the outer 3/16” diameter port.

EDELBROCK CARBURETOR INSPECTION

1. Check for possible damage to the carburetor.
2. Make sure all throttle linkages operate freely.
3. Ensure that all fuel inlet, vacuum ports and throttle bores are free from packing material.

CARBURETOR REMOVAL

1. Prior to removal, make sure that the engine is cool.
2. Disconnect the negative battery cable from the battery.
3. Remove air cleaner. Be sure to carefully disconnect any hoses from the air cleaner and note their location for reinstallation. You may want to mark them with masking tape for easy reference.

4. Disconnect throttle linkage, kickdown linkage (certain automatic transmission applications only), cruise control (if equipped) and any return springs if present.

NOTE: Check carefully for the precise location of all these linkages and return springs. You may want to mark them with masking tape for easy reference.

5. Disconnect all wires, tubes, and hoses from carburetor and note their locations.

6. Carefully remove the fuel line from the carburetor. **TAKE EXTREME CARE TO NOT SPILL ANY EXCESS FUEL.**

Place a rag underneath the fuel line to absorb any spillage that may occur. Certain models require two wrenches to remove the fuel line; one to hold the fitting on the carburetor and the second to turn the fitting on the fuel line. Use a tubing wrench to avoid rounding the tube fitting nut.

7. Remove mounting nuts or bolts and washers. Be sure to put them where they won't fall into the intake manifold upon carburetor removal.

8. Remove carburetor, being careful not to spill any dirt into the intake manifold. Cover the intake manifold to keep foreign objects out.

9. Remove the gasket and thoroughly clean mounting surface. Compare old carb gasket to the gasket included with your Edelbrock carburetor. VRS-4150 carburetors are only compatible with 4150 style square bore or 4500 style intake manifolds. 4500 manifolds require a 4500 style carb gasket.

CARBURETOR PREPARATION

1. Compare the throttle arm of your new carburetor with the old one to be sure that all required linkages will hook up. Install the proper throttle and transmission linkage for your application. Throttle stud is removable and must be installed in the proper location.

CARBURETOR INSTALLATION

1. Remove cover from intake manifold and install new studs and carb gasket. When installed, there should be about 1/4" of stud exposed above the nut. If the stud is too long, it will be difficult to adjust the idle mixture screws.
2. It will be easier to connect the vacuum hoses to the carburetor before setting it down fully on the manifold. (see Fig1 on page 3). Replace brittle or cracked hoses.
3. Hand tighten nuts with a short wrench, alternating between diagonally opposed studs.

IMPORTANT NOTE: *Check for interference between the accel pump well, lever and the intake manifold.*

4. Connect all throttle and transmission linkages and throttle return springs. You may have to cut, bend or modify your current throttle cable brackets to fit the new carburetor, or use Edelbrock Throttle Cable Bracket PN 8041.

IMPORTANT NOTE: *With engine OFF, make sure that there is no interference when opening and closing the throttle. Be sure there is no binding or hanging up between idle and wide-open throttle, as this could cause the throttle to stick open, resulting in loss of engine speed control. Also check that the blades are fully open when the gas pedal is fully pressed.*

5. Connect fuel lines to carburetor. Avoid contact with any sharp edges or areas of extreme heat.
6. Install new air cleaner gasket and air cleaner stud (supplied). The VRS- 4150 carburetors are threaded for 5/16" -18 studs. (3" included). Install air cleaner, making sure it does not contact the carburetor linkage or fuel line, and has proper hood clearance. We recommend Edelbrock Pro-Flo chrome air cleaner #1224 with cotton Gauze element or #1225 in black. Both are low profile 14" diameter with 3" tall element. 2" tall filter elements can help where hood clearance is an issue.

7. CAUTION: The VRS series carburetors are 1/2" taller than standard carburetors. Check hood clearance carefully especially the carb stud, trim as necessary.

NOTE: Running without an air cleaner is strongly discouraged for a street-driven vehicle. Dirt and varnish will accumulate in critical bleeds and upset the fuel metering.

8. Recheck all linkages for smooth throttle operation.
9. Reconnect the negative battery cable from the battery.

IMPORTANT WARNING BEFORE STARTING THE ENGINE

- **Be sure all vacuum lines are properly connected.**
- **Check for signs of flooding before operating vehicle.** If flooding occurs, see "If You Have a Problem" section on Page #9.
- **Do not pump the accelerator more than two or three times with the engine off.** VRS carbs are capable of delivering a large amount of fuel, making it easy to flood the engine.

10. Start engine and check for fuel or vacuum leaks. With engine at normal operating temperature, on the 850 CFM model set idle speed using either 1/4" hex adjuster located on the side of the main body above the Edelbrock logo. To lower idle speed turn screw clockwise, to increase idle speed, turn the screw counterclockwise. Because the auxiliary circuit bypasses air, this will lean the idle mixture slightly. Due to the large bore diameter of the 950 CFM carb the auxiliary idle air circuit could not be included.

CAUTION: Be alert of carburetor flooding when fuel is first applied. Flooding can be caused by dirt, small particles from hose cutting, floats and inlet needles which have settled during shipping, or by other conditions as discussed below. Each Edelbrock carburetor is flow tested in the factory for both air and liquid flow so flooding

is rare. However, for safety's sake please observe this caution. When the fuel pump is turned on or when the engine is first started, watch closely for signs of flooding. Fuel level should be up to the middle of the sight glass on the side of the bowl. If flooding is apparent, tap the body of the carburetor lightly with a rawhide mallet or the wooden handle of a small hammer. If flooding continues, pinch the fuel line hose to shut off flow, run the engine to clear the carburetor then let the fuel line flow again. If flooding continues, shut off the engine. Clean up any raw fuel and refer to the "Trouble Shooting" section on page 9.

WARNING: Fuel may be added to an empty fuel bowl through the vent tubes, but never pour fuel directly into the barrels! This may cause a backfire, possible engine fire, and result in engine or vehicle damage, personal injury, and/or death.

IDLE MIXTURE

The Edelbrock VRS-4150 carburetors have 4 conventional Idle Mixture Screws (IMS) that provide a leaner A/F when turned clockwise and richer A/F when turned counterclockwise. The following procedure should be used to set the idle mixture and speeds.

1. Fully warm engine
2. Air cleaner in place.
3. Set desired speed with the idle speed screw.
4. Adjust all four IMS 1/4" turn at a time to get maximum idle RPM.
5. If the idle speed changes more than 40 rpm, adjust the idle speed screw or the main body auxiliary idle screws.
6. Go leaner just enough to get a 20 RPM drop in speed.
7. This is a Lean-Best Idle Set. Setting richer than this will not improve idle quality or performance but could tend to foul plugs.

LONG DURATION CAMSHAFT

If the engine has a fairly radical camshaft it may require an excessive amount of throttle opening for idle

and/or have low idle vacuum levels. If the throttle blades are adjusted open enough to expose more than a few thousandths of the transfer slot excessive fuel will enter the engine, leading to poor levels of adjustability and erratic idles. On the 850 CFM PN 1308-E85 use the auxiliary screws to add air without disturbing the throttle blade position. Another fix for the above condition is to run as much spark advance as possible at idle. If the distributor is fitted with a vacuum advance unit, connect it directly to manifold vacuum. If you are not able to employ vacuum advance for some reason, then the mechanical curve should have a low limit, which will allow you to use plenty of initial spark advance.

FLOAT ADJUSTMENT

1. Float level adjustment is performed on a running engine. Fuel level should be in the middle of the sight glass. Generally, the carburetor as shipped will not require adjustment.
2. If adjustment is required first slightly loosen the lock screw with a large flat blade screwdriver. Do not excessively loosen the screw as fuel may leak out. The "nut" is actually a keyed collar. turning it clockwise drives the needle and seat further into the bowl, lowering the fuel level. Turning it counter-clockwise raises the needle and therefor raising the fuel level.
3. Hold the adjusting nut with a hex wrench and tighten the lock screw. If the level was too high before the adjustment rev the engine to consume the excess fuel in the bowl.

IF YOU HAVE A PROBLEM

- **If your engine has a rough idle or hesitates off-idle**, readjust your idle mixture (see page 6). A good starting point is 1-1/4 turn out from seated. If you have a vacuum advance unit on your distributor, make sure it is connected to the proper vacuum source see Figure 2 and Step 2 of Page 4 - "Before Removing Old Carburetor"
- **A hesitation can be from a loosely adjusted accel pump arm bolt.** Using a 3/8" open end wrench on the bolt head, and a 3/8" socket on the nut, loosen the nut to take out all the lash in the assembly. With zero or slightly negative lash way the accel pump fuel will squirt immediately as the throttle is cracked.
- **If flooding occurs it may be caused by 1)** dirt or debris stuck between the needle and seat; **2)** the floats are out of adjustment or **3)** too much fuel pressure. First, remove the needle and seat and look for foreign debris. Use a fuel filter to prevent this problem in the future. See page 8 for more information on the float level. Make sure fuel pressure does not exceed 7.0 psi. Flooding is not a symptom of a faulty carburetor.
- **If fuel drips from the throttle shaft**, this is caused by excessive pumping of accelerator pedal with engine off or heat soak.

If you have any questions or concerns with the installation or performance, do not return to the carburetor to the retailer...call the Edelbrock Carb Tech Hotline at 800-416-8628 from 7am - 7pm CST Monday-Friday. All returns must be accompanied by the original purchase receipt. The warranty period is 90 days for new VRS-4150 Carburetors

WARRANTY

EDELBROCK warrants its VRS-4150 Race and Performance Carburetors to be free from defects in material or workmanship. This warranty is valid provided that the product is properly installed, subjected to normal use and service and is not modified or changed in any way. This warranty is extended to only the original consumer purchaser, the warranty period is 12 months days for VRS Carburetors. Any implied warranty determined to be applicable is limited in duration to the duration of this warranty. Some states do not allow limitations on how long an implied warranty is so the above limitation may not apply to you.

In the event of a defect in material or workmanship, **EDELBROCK'S** sole responsibility is to repair or replace the defective product. This warranty covers the replacement or repair at **EDELBROCK'S** option of the product only and does not cover the cost of removal or installation of the product. Final warranty determination will be the decision of **EDELBROCK**.

EDELBROCK does not warrant products which have been modified or altered outside factory specifications; subjected to conditions such as misuse, neglect, accident, improper installation or adjustment, dirt or other contaminants, weather or corrosion, gum or varnish, use of improper or poor quality fuel or fuel additives, improper fuel pressure and faulty repair or use in other than those automotive applications recommended in a current **EDELBROCK** catalog. Further, there are no warranties which extend beyond those stated here.

EDELBROCK shall not be responsible for (a) actual or alleged labor, transportation or other incidental charges or (b) actual or alleged consequential or other damages incurred by use of **EDELBROCK** VRS- 4150 Carburetors. **EDELBROCK GROUP** shall not be liable for any and all consequential damages occasioned by the breach of any written or implied warranty pertaining to this sale in excess of the purchase price of the product.

If you have any questions or concerns with the installation or performance, do not return to the carburetor to the retailer...
call the Edelbrock Carb Tech Hotline at 800-416-8628
from 7am - 7pm CST Monday-Friday.

This warranty gives you specific legal rights, and you may also have other rights which vary from state to state.

The general limited Warranty supersedes all prior warranty statements. Inquiries concerning this warranty should be directed to:

Edelbrock Group
8649 Hacks Cross Road
Olive Branch, MS 38654
Tech Line: (800) 416-8628

CALIBRATION:

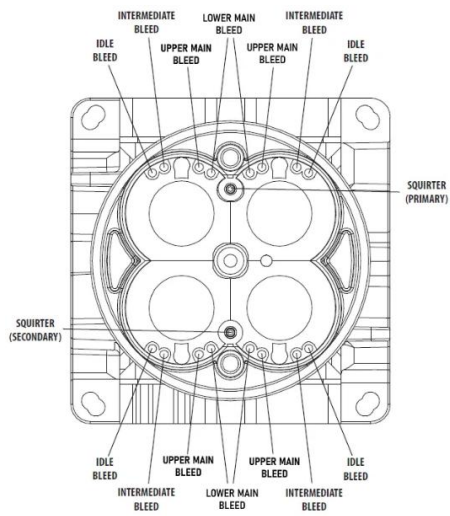

ITEM:	1308-E85	1309-E85
Booster	Annular	Annular
Idle Air Bleeds	.070	.070
Intermediate Bleed	.053	.053
Upper Main Bleed	.023	.023
Lower Main Bleed	.023	.023
Primary Squirter	.040	.040
Secondary Squirter	.040	.040
Jet (Primary)	#76	#84
Jet (Secondary)	#76	#84
Power Valve	4.5Hg	4.5Hg
PV Channel Restrictor	.083	.083

COMPATIBILITY

ITEM	THREAD	NOTES:	EDELBROCK PN
Fuel Bowl Inlets	7/8-20	Comes with -6AN fittings installed	
Jets	1/4-32	Standard – Available in our HDQ line	PN'S 12455-12485
Air Bleeds	#10-32	Standard	
Emulsion Bleeds	#6-32	Standard	
Accel Pump Diaphragm		50cc, GFLT	
Power Valve		Standard, 4-Window	PN'S 13145, 13165
Needle and Seat		Stainless Steel, Adjustable .130	
Bowl Screw Seal		Standard	PN 13112
Pump Cam		Custom due to 1/2" throttle shaft	PN 13110 30 cc PN 13111 50 cc
Metering Blocks		Custom Four Circuit	
Metering Block Gaskets		Custom for four circuit geometry	PN 13101
Bowl Screws	#12-24	Custom 2.80" length	
Float		Custom – 1/8 longer than std.	PN 13108



VRS-4150

E85 SERIES CARBURETOR



**For further information contact the
Edelbrock Technical Department:
Between 7:00 am and 7:00 pm CST,
Monday through Friday
Tech Line: (800) 416-8628
edelbrock.com**